

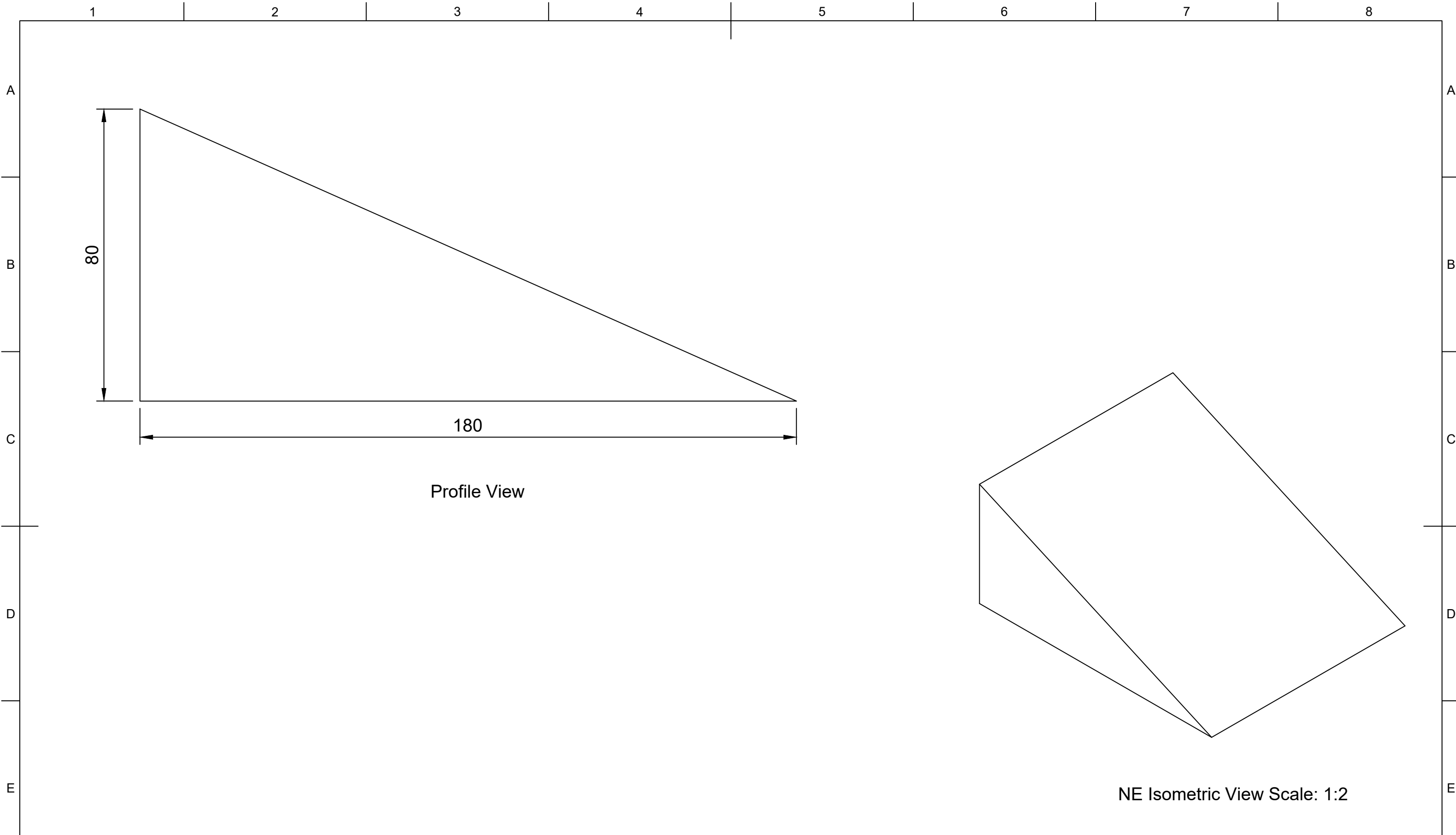



## Wedges



Profile View

NE Isometric View Scale: 1:2

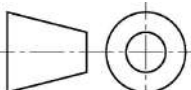
	<b>Part Number</b>				<b>Created By</b>		<b>Cross Sectional Area (mm<sup>2</sup>)</b>		<b>Nominal Dimension (mm)</b>		<b>Tolerance, ± (mm)</b>
	205026				Isaac Erskine		7200		<b>Greater Than</b>	<b>Less Than or Equal to</b>	
	<b>Description</b>				<b>Date Drawn</b>		<b>Material</b>		0.00	1.50	0.40
	Wedge				23/09/2020		Nitrile		1.50	2.50	0.50
	<b>Revision</b>				<b>Approved By</b>		<b>Hardness (Shore A)</b>		2.50	4.00	0.70
	A	21/02/2022		Isaac Erskine		70		4.00	6.30	0.80	
	<b>Date of Issue</b>				<b>Date of Approval</b>		<b>Colour</b>		6.30	10.00	1.00
	21/02/2022				21/02/2022		Black		10.00	16.00	1.30
	<b>Sheet Scale</b>				<b>Projection</b>		<b>Weight (kg/m)</b>		16.00	25.00	1.60
	1:1				3rd Agl. 		8.712		25.00	40.00	2.00
<b>Sheet Size</b>								40.00	63.00	2.50	
A3								63.00	100.00	3.20	
<b>Sheet</b>								100.00		3.20%	
1/1											

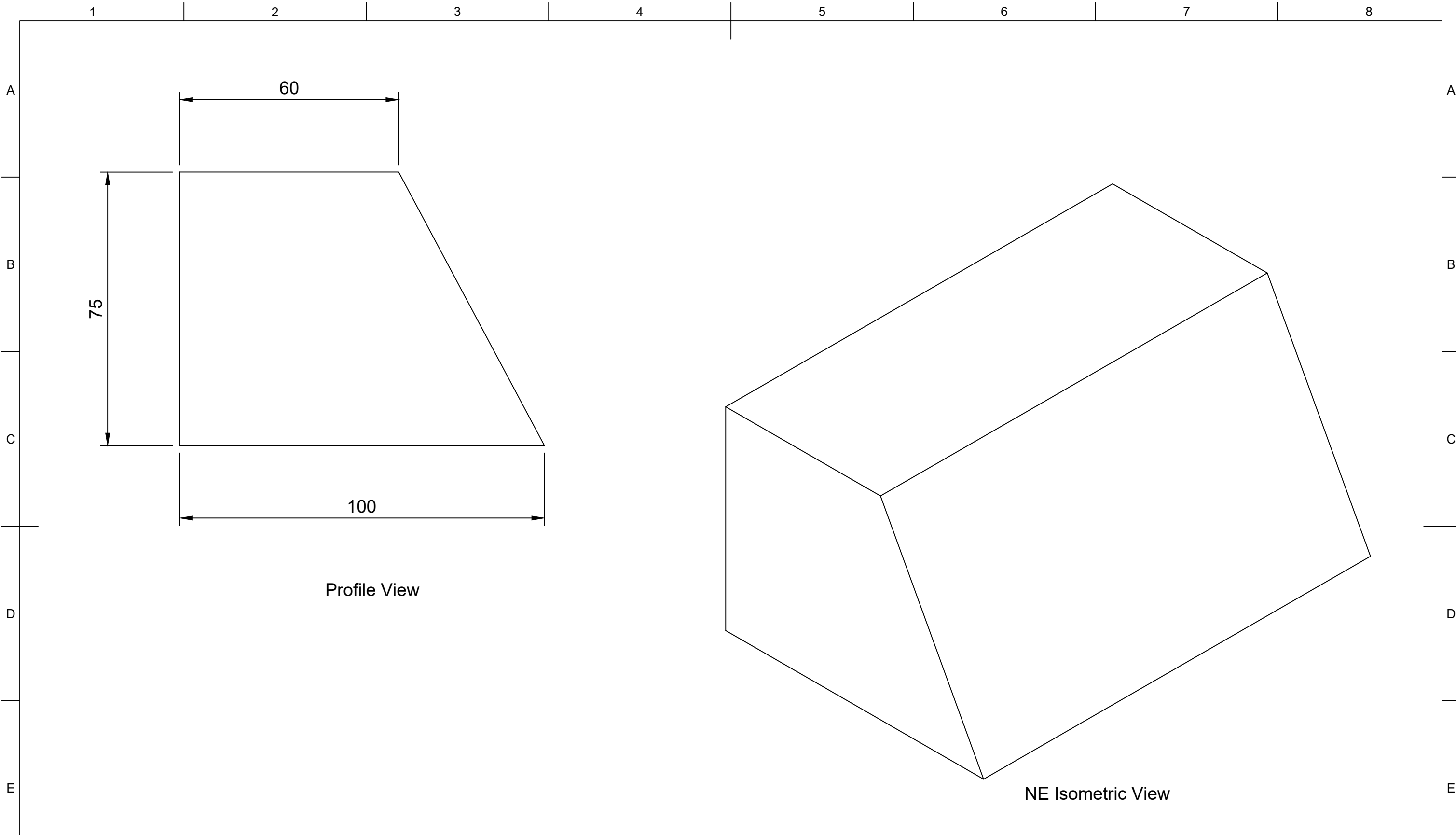

	<b>Part Number</b>				<b>Created By</b>		<b>Cross Sectional Area (mm<sup>2</sup>)</b>		<b>Nominal Dimension (mm)</b>		<b>Tolerance, ± (mm)</b>													
	203211				Isaac Erskine		6000		<b>Greater Than</b>	<b>Less Than or Equal to</b>														
	<b>Description</b>				<b>Date Drawn</b>		<b>Material</b>		0.00		1.50		0.40											
					12/08/2020		EPDM		1.50		2.50		0.50											
	Wedge (Lipped)				<b>Approved By</b>		<b>Hardness (Shore A)</b>		2.50		4.00		0.70											
					Isaac Erskine		70		4.00		6.30		0.80											
					<b>Date of Approval</b>		<b>Colour</b>		6.30		10.00		1.00											
	17/02/2022		Black		10.00		16.00		1.30															
	<table border="1" style="width: 100%; border-collapse: collapse;"> <tr> <td style="width: 10%;"><b>Revision</b></td> <td style="width: 15%;"><b>Date of Issue</b></td> <td style="width: 10%;"><b>Sheet Scale</b></td> <td style="width: 10%;"><b>Sheet Size</b></td> <td style="width: 10%;"><b>Sheet</b></td> </tr> <tr> <td style="text-align: center;">A</td> <td style="text-align: center;">17/02/2022</td> <td style="text-align: center;">1:1</td> <td style="text-align: center;">A3</td> <td style="text-align: center;">1/1</td> </tr> </table>				<b>Revision</b>	<b>Date of Issue</b>	<b>Sheet Scale</b>	<b>Sheet Size</b>	<b>Sheet</b>	A	17/02/2022	1:1	A3	1/1	<b>Projection</b>		<b>Weight (kg/m)</b>		16.00		25.00		1.60	
					<b>Revision</b>	<b>Date of Issue</b>	<b>Sheet Scale</b>	<b>Sheet Size</b>	<b>Sheet</b>															
A					17/02/2022	1:1	A3	1/1																
3rd Agl.					7.560		25.00		40.00		2.00													
		40.00		2.50		63.00		3.20																
		63.00		3.20		100.00		3.20																
		100.00		3.20%		—		3.20%																

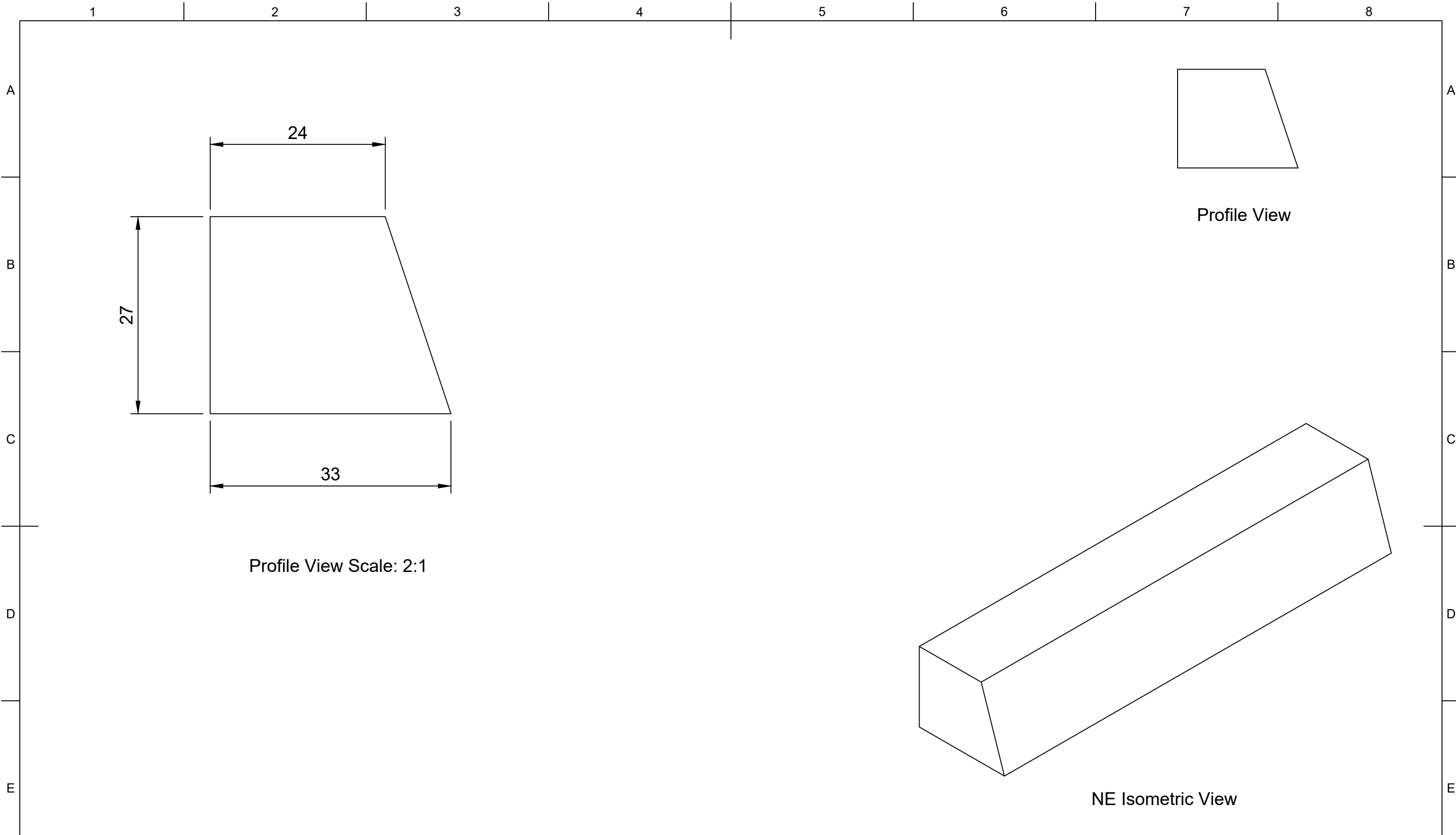

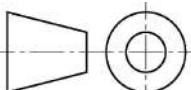
	<b>Part Number</b>				<b>Created By</b>		<b>Cross Sectional Area (mm<sup>2</sup>)</b>		<b>Nominal Dimension (mm)</b>		<b>Tolerance, ± (mm)</b>
	208549				Isaac Erskine		770		<b>Greater Than</b>	<b>Less Than or Equal to</b>	
					Date Drawn		Material		0.00	1.50	0.40
					12/08/2020		EPDM		1.50	2.50	0.50
	<b>Description</b>				<b>Approved By</b>		<b>Hardness (Shore A)</b>		2.50	4.00	0.70
	Wedge (Lipped)				Isaac Erskine		70		4.00	6.30	0.80
					Date of Approval		Colour		6.30	10.00	1.00
					17/02/2022		Black		10.00	16.00	1.30
									16.00	25.00	1.60
									25.00	40.00	2.00
<b>Revision</b>	<b>Date of Issue</b>	<b>Sheet Scale</b>	<b>Sheet Size</b>	<b>Sheet</b>	<b>Projection</b>	<b>Weight (g/m)</b>		40.00	63.00	2.50	
A	17/02/2022	1:1	A3	1/1	3rd Agl. 	970		63.00	100.00	3.20	
								100.00		3.20%	

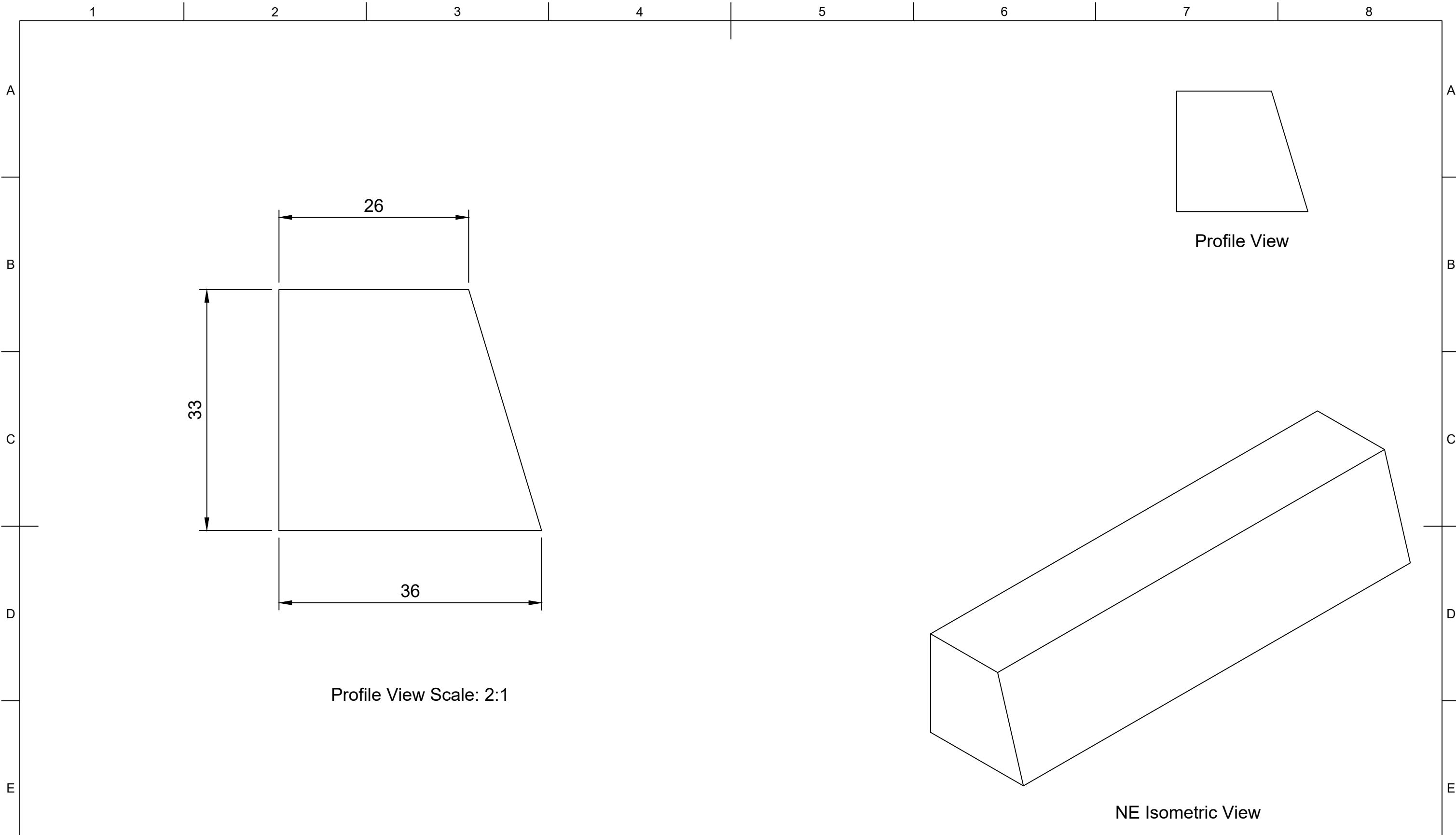

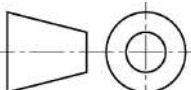
	<b>Part Number</b>				<b>Created By</b>		<b>Cross Sectional Area (mm<sup>2</sup>)</b>		<b>Nominal Dimension (mm)</b>		<b>Tolerance, ± (mm)</b>
	208743				Isaac Erskine		1023		<b>Greater Than</b>	<b>Less Than or Equal to</b>	
	<b>Description</b>				<b>Date Drawn</b>		<b>Material</b>		0.00	1.50	0.40
					12/08/2020		Neoprene		1.50	2.50	0.50
	Wedge (Lipped)				<b>Approved By</b>		<b>Hardness (Shore A)</b>		2.50	4.00	0.70
					Isaac Erskine		70		4.00	6.30	0.80
					<b>Date of Approval</b>		<b>Colour</b>		6.30	10.00	1.00
	17/02/2022		Black		10.00	16.00	1.30				
	<b>Revision</b>	<b>Date of Issue</b>	<b>Sheet Scale</b>	<b>Sheet Size</b>	<b>Sheet</b>	<b>Projection</b>	<b>Weight (kg/m)</b>		16.00	25.00	1.60
	A	17/02/2022	1:1	A3	1/1	3rd Agl. 	1.555		25.00	40.00	2.00
								40.00	63.00	2.50	
								63.00	100.00	3.20	
								100.00		3.20%	

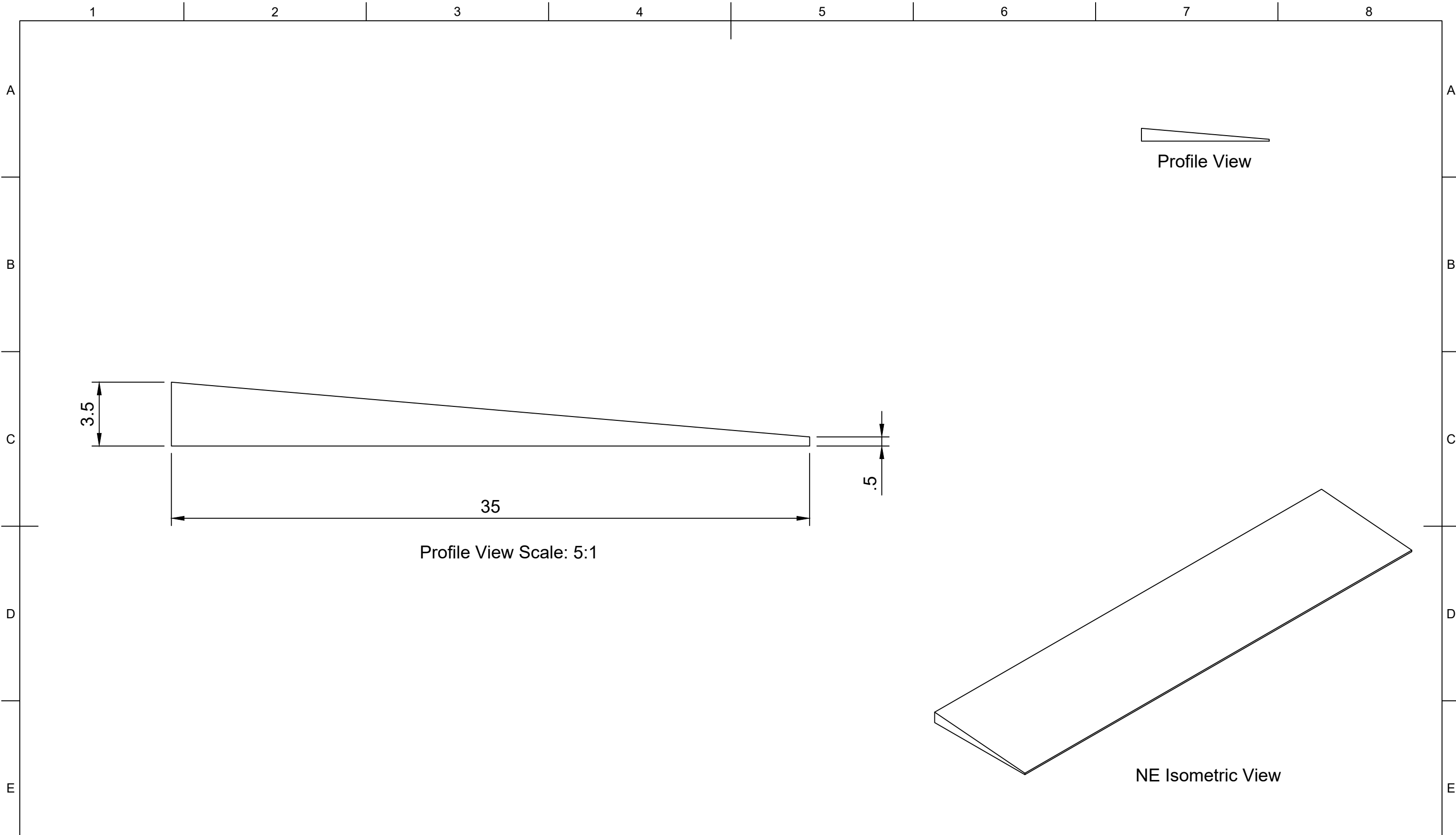

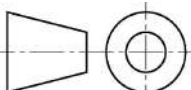
	<b>Part Number</b>				<b>Created By</b>		<b>Cross Sectional Area (mm<sup>2</sup>)</b>		<b>Nominal Dimension (mm)</b>		<b>Tolerance, ± (mm)</b>
	205439				Isaac Erskine		70		<b>Greater Than</b>	<b>Less Than or Equal to</b>	
	<b>Description</b>				<b>Date Drawn</b>		<b>Material</b>				
	Wedge (Lipped)				04/11/2020		EPDM				
					<b>Approved By</b>		<b>Hardness (Shore A)</b>				
					Isaac Erskine		70				
					<b>Date of Approval</b>		<b>Colour</b>				
					21/02/2022		Black				
					<b>Projection</b>		<b>Weight (g/m)</b>				
					3rd Agl. 		88				
<b>Revision</b>	<b>Date of Issue</b>	<b>Sheet Scale</b>	<b>Sheet Size</b>	<b>Sheet</b>							
A	21/02/2022	1:1	A3	1/1							

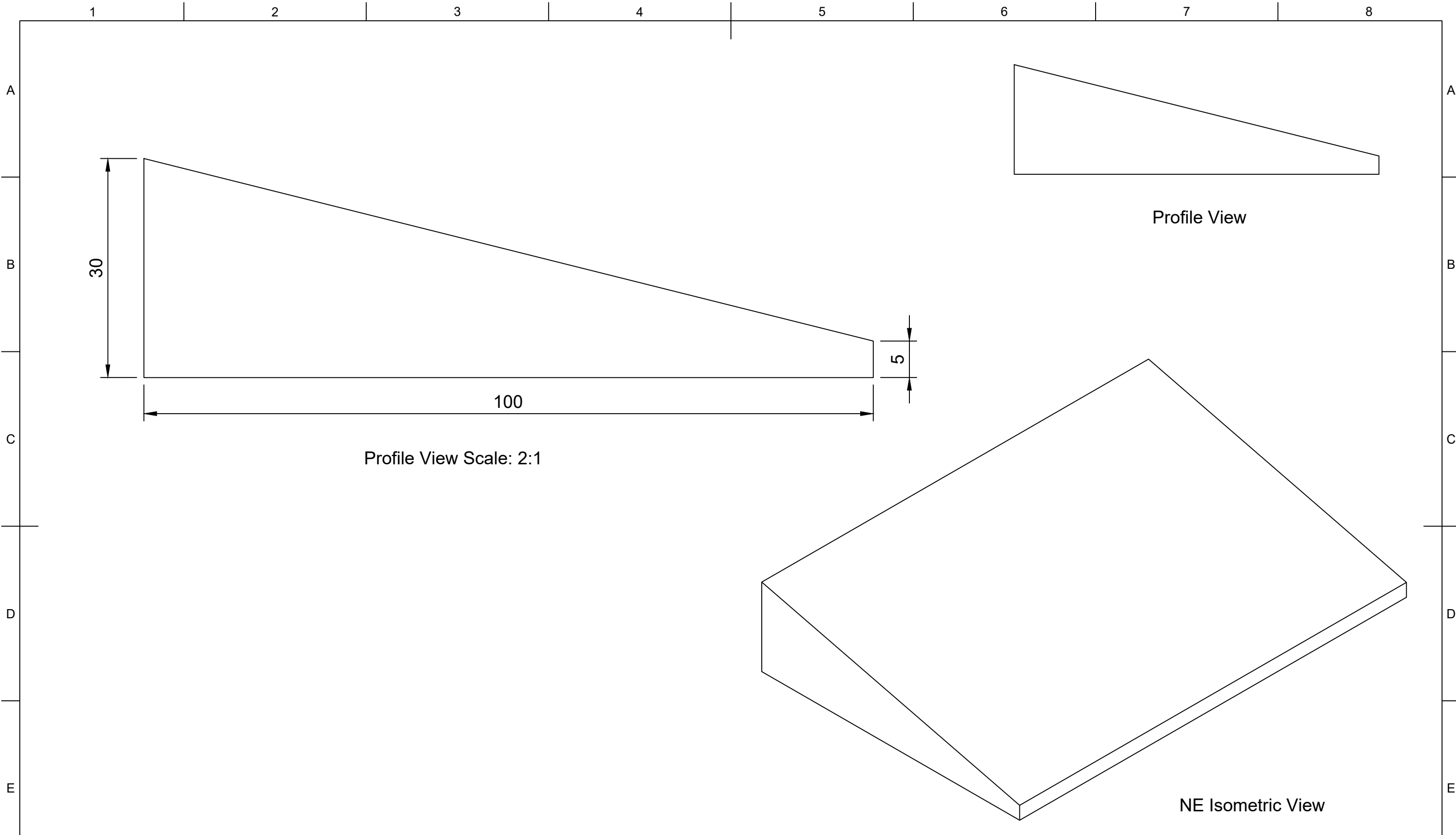

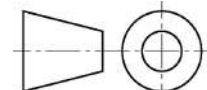

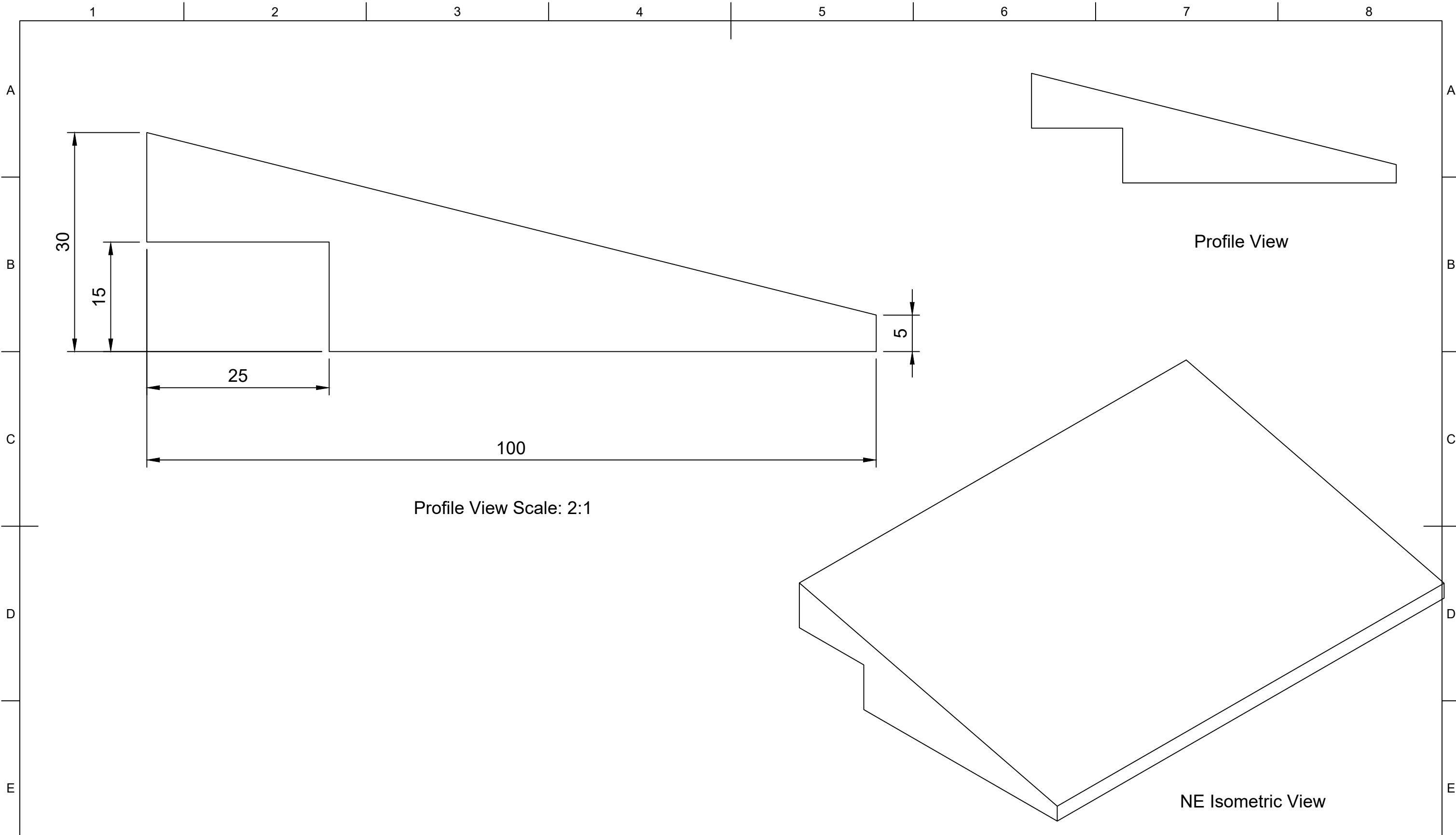
<b>Part Number</b> 206154		<b>Created By</b> Isaac Erskine		<b>Cross Sectional Area (mm<sup>2</sup>)</b> 1750		<b>Nominal Dimension (mm)</b>		<b>Tolerance, ± (mm)</b>
		<b>Date Drawn</b> 23/09/2020		<b>Material</b> EPDM		<b>Greater Than</b>	<b>Less Than or Equal to</b>	
<b>Description</b> Wedge (Lipped)		<b>Approved By</b> Isaac Erskine		<b>Hardness (Shore A)</b> 70		0.00	1.50	0.40
		<b>Date of Approval</b> 21/02/2022		<b>Colour</b> Black		1.50	2.50	0.50
		<b>Projection</b> 3rd Agl. 		<b>Weight (kg/m)</b> 2.205		2.50	4.00	0.70
<b>Revision</b> A	<b>Date of Issue</b> 21/02/2022	<b>Sheet Scale</b> 1:1	<b>Sheet Size</b> A3	<b>Sheet</b> 1/1		4.00	6.30	0.80
						6.30	10.00	1.00
						10.00	16.00	1.30
						16.00	25.00	1.60
						25.00	40.00	2.00
						40.00	63.00	2.50
						63.00	100.00	3.20
						100.00		3.20%



Part Number		201194			Created By	Isaac Erskine	Cross Sectional Area (mm <sup>2</sup> )	1500		Nominal Dimension (mm)		Tolerance, ± (mm)
					Date Drawn	23/09/2020	Material	EPDM	Greater Than	Less Than or Equal to		
Description		Wedge (Lipped)			Approved By	Isaac Erskine	Hardness (Shore A)	70		0.00	1.50	0.40
					Date of Approval	21/02/2022	Colour	Black	1.50	2.50	0.50	
Revision	Date of Issue	Sheet Scale	Sheet Size	Sheet	Projection	3rd Agl.	Weight (kg/m)	1.890		2.50	4.00	0.70
A	21/02/2022	2:1	A3	1/1			25.00	40.00	2.00			
										63.00	100.00	3.20
										100.00		3.20%

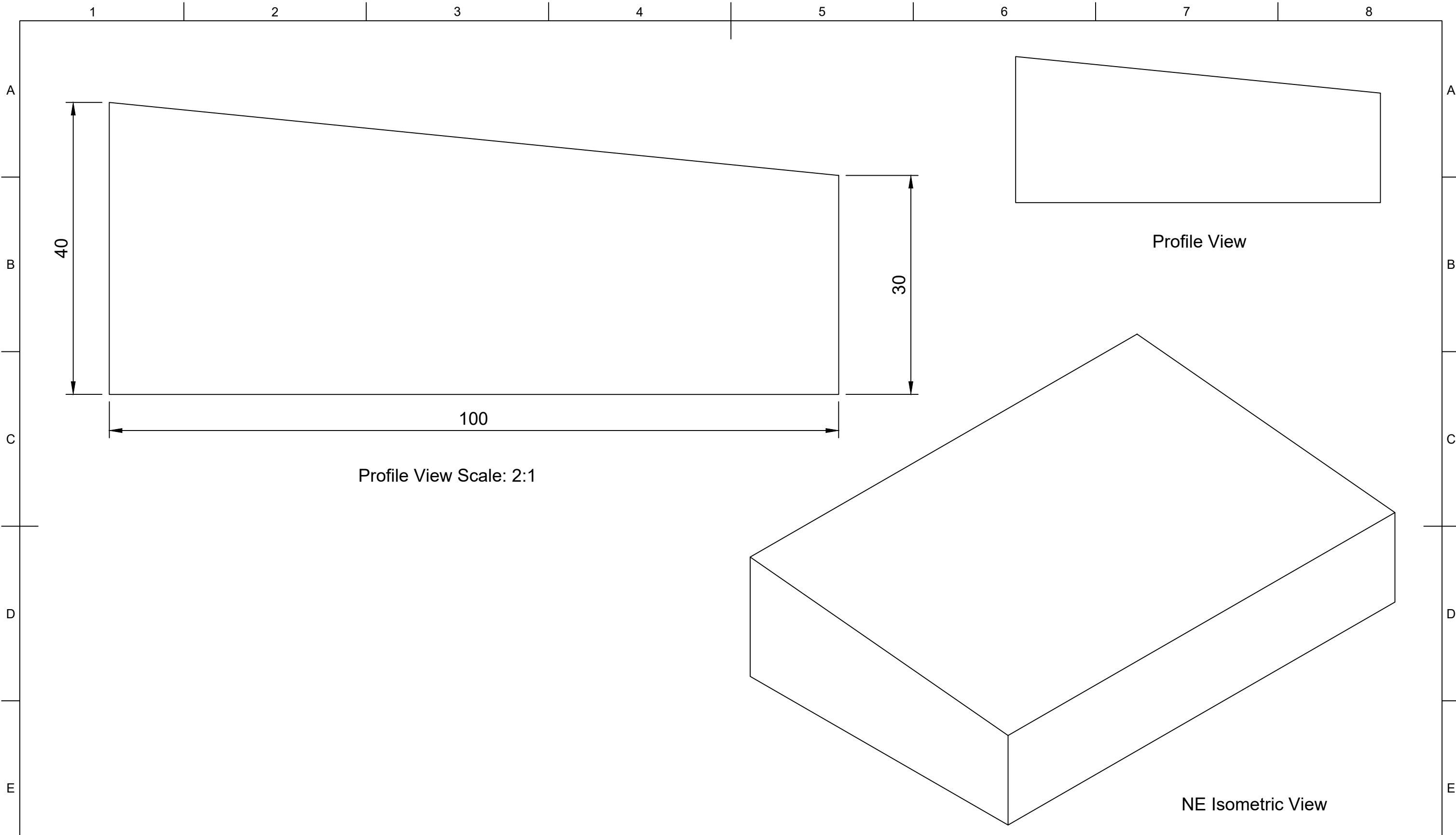

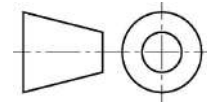

	<b>Part Number</b>				<b>Created By</b>		<b>Cross Sectional Area (mm<sup>2</sup>)</b>		<b>Nominal Dimension (mm)</b>		<b>Tolerance, ± (mm)</b>
	203595				Isaac Erskine		3500		<b>Greater Than</b>	<b>Less Than or Equal to</b>	
					Date Drawn		Material		0.00	1.50	0.40
					23/09/2020		EPDM		1.50	2.50	0.50
	<b>Description</b>				<b>Approved By</b>		<b>Hardness (Shore A)</b>		2.50	4.00	0.70
	Wedge (Lipped)				Isaac Erskine		70		4.00	6.30	0.80
					Date of Approval		Colour		6.30	10.00	1.00
					21/02/2022		Black		10.00	16.00	1.30
							Weight (kg/m)		16.00	25.00	1.60
							4.410		25.00	40.00	2.00
<b>Revision</b>	<b>Date of Issue</b>	<b>Sheet Scale</b>	<b>Sheet Size</b>	<b>Sheet</b>	<b>Projection</b>			40.00	63.00	2.50	
A	21/02/2022	1:1	A3	1/1	3rd Agl.			63.00	100.00	3.20	
								100.00		3.20%	

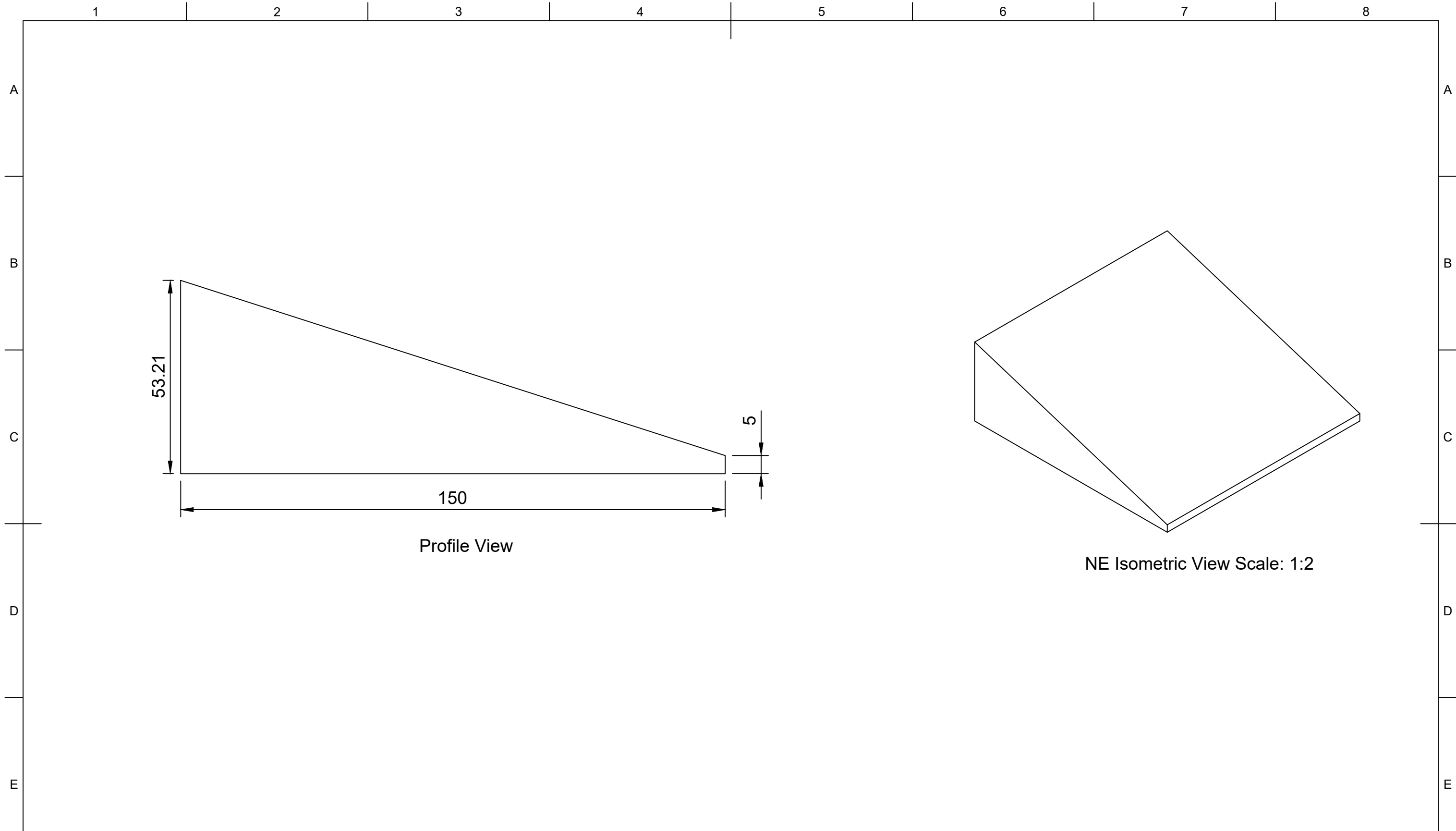

Profile View

NE Isometric View Scale: 1:2

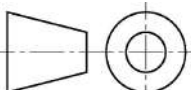
	<b>Part Number</b>				<b>Created By</b>		<b>Cross Sectional Area (mm<sup>2</sup>)</b>		<b>Nominal Dimension (mm)</b>		<b>Tolerance, ± (mm)</b>
	202698				Isaac Erskine		4366		<b>Greater Than</b>	<b>Less Than or Equal to</b>	
	<b>Description</b>				<b>Date Drawn</b>		<b>Material</b>		0.00		0.40
	Wedge (Lipped)				02/07/2020		EPDM		1.50		0.50
	<b>Revision</b>				<b>Approved By</b>		<b>Hardness (Shore A)</b>		2.50		0.70
	A	21/02/2022		Isaac Erskine		70		4.00		0.80	
	<b>Date of Issue</b>				<b>Date of Approval</b>		<b>Colour</b>		6.30		1.00
	<b>Sheet Scale</b>				21/02/2022		Black		10.00		1.30
	<b>Sheet Size</b>				<b>Projection</b>		<b>Weight (kg/m)</b>		16.00		1.60
	A3				3rd Agl. 		5.501		25.00		2.00
<b>Sheet</b>								40.00		2.50	
1/1								63.00		3.20	
								100.00		3.20%	

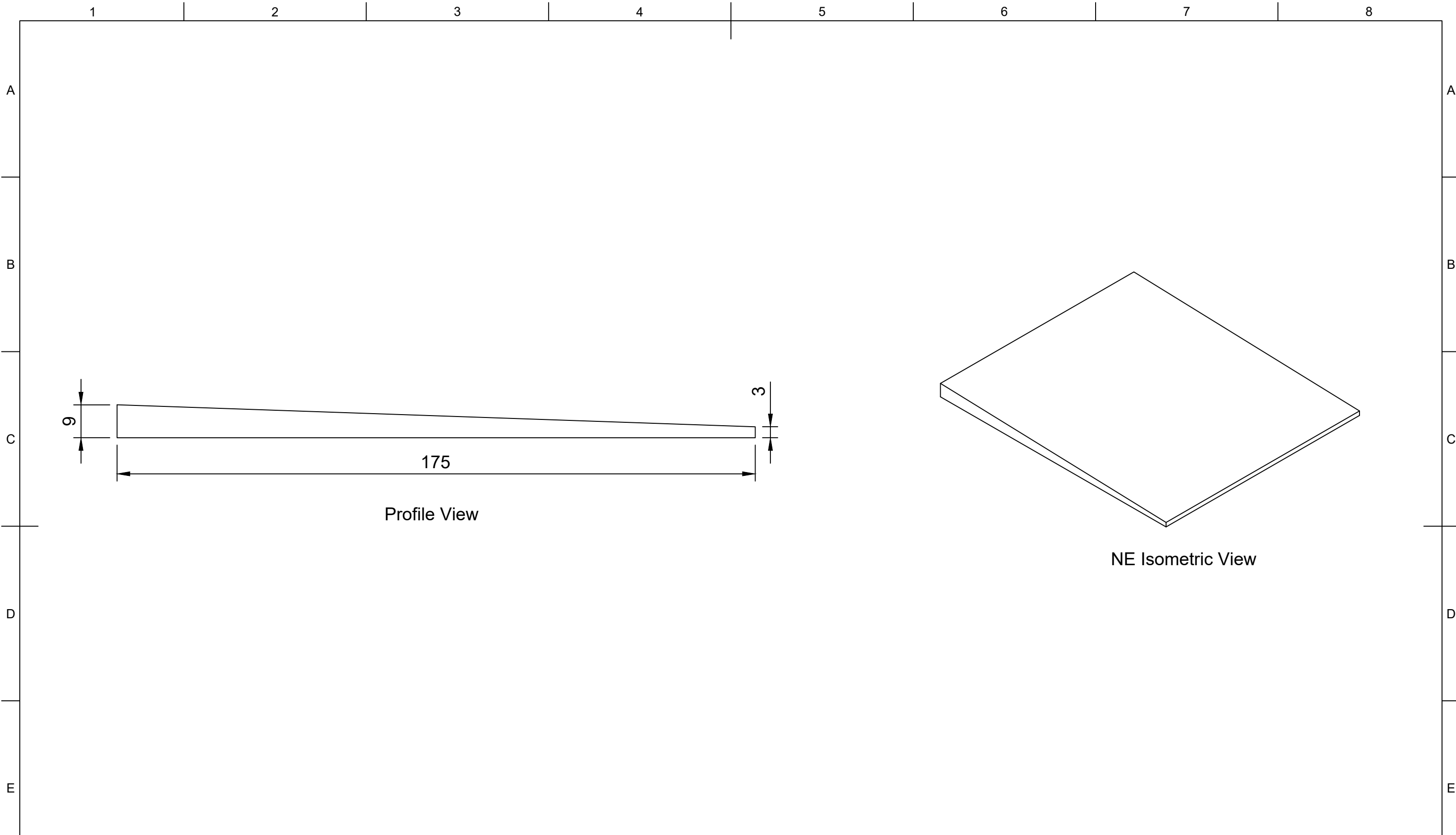

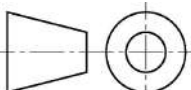
	<b>Part Number</b>				<b>Created By</b>		<b>Cross Sectional Area (mm<sup>2</sup>)</b>		<b>Nominal Dimension (mm)</b>		<b>Tolerance, ± (mm)</b>
	209736				Isaac Erskine		1050		<b>Greater Than</b>	<b>Less Than or Equal to</b>	
	<b>Description</b>				<b>Date Drawn</b>		<b>Material</b>		0.00	1.50	0.40
	Wedge (Lipped)				23/09/2020		Neoprene		1.50	2.50	0.50
	<b>Revision</b>				<b>Approved By</b>		<b>Hardness (Shore A)</b>		2.50	4.00	0.70
	A	21/02/2022		1:1	A3	1/1	Isaac Erskine		4.00	6.30	0.80
	<b>Date of Issue</b>				<b>Date of Approval</b>		<b>Colour</b>		6.30	10.00	1.00
	<b>Sheet Scale</b>				<b>Projection</b>		<b>Weight (kg/m)</b>		10.00	16.00	1.30
	<b>Sheet Size</b>				3rd Agl. 		1.596		16.00	25.00	1.60
	<b>Sheet</b>								25.00	40.00	2.00
								40.00	63.00	2.50	
								63.00	100.00	3.20	
								100.00		3.20%	

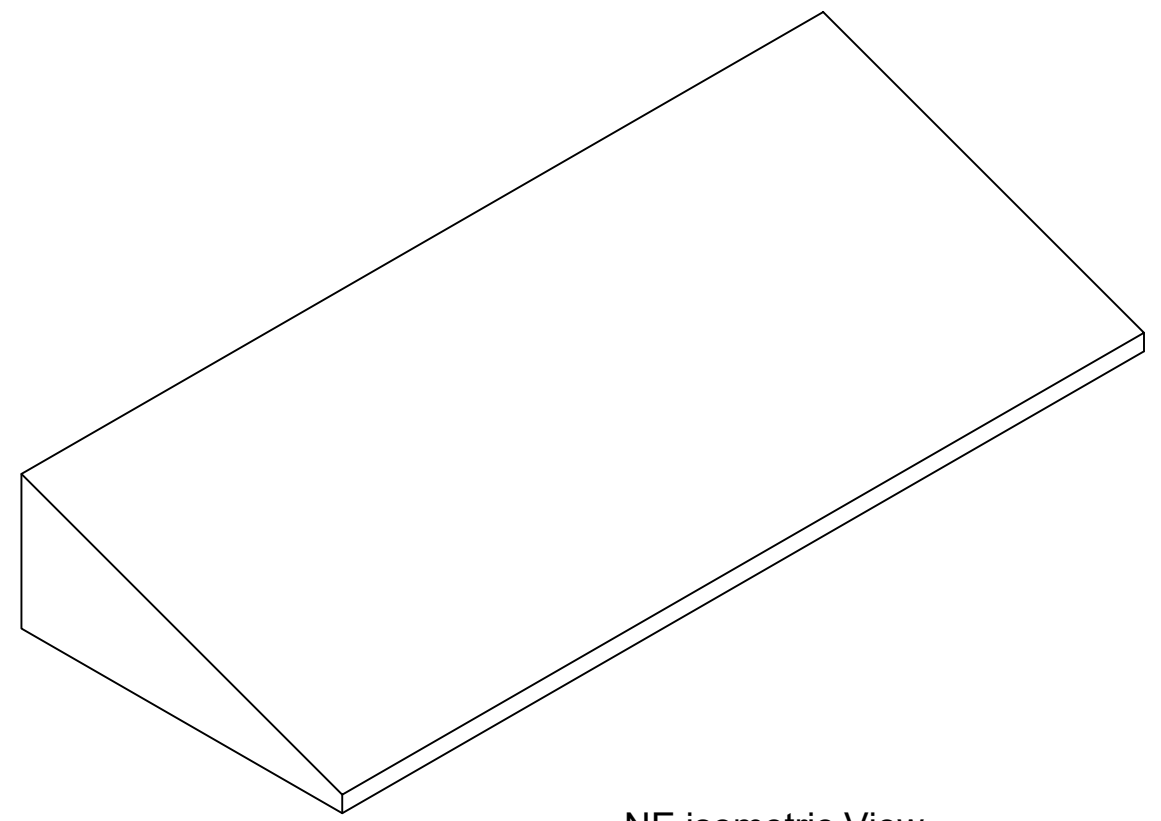
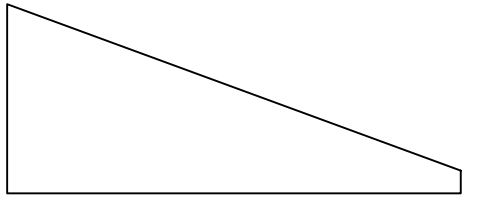
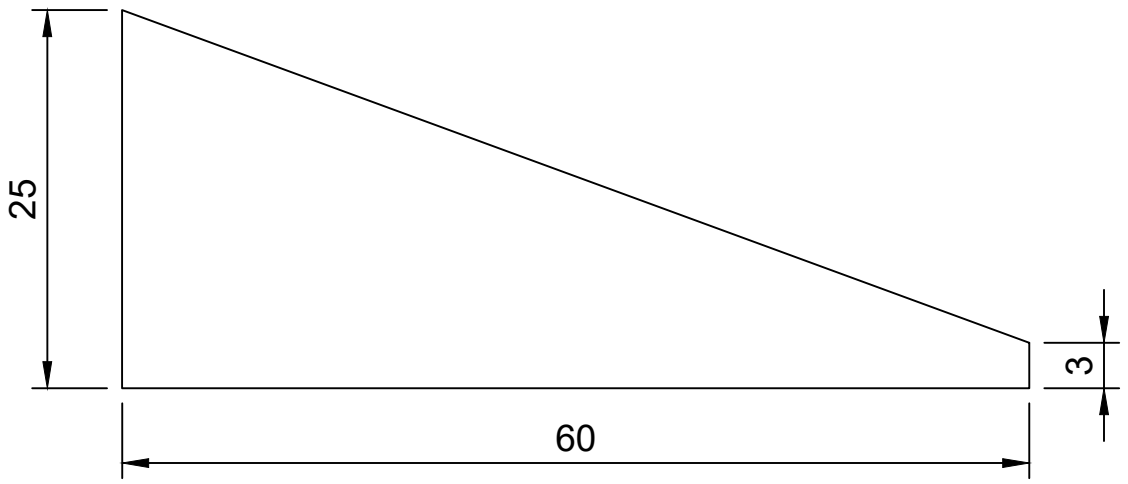
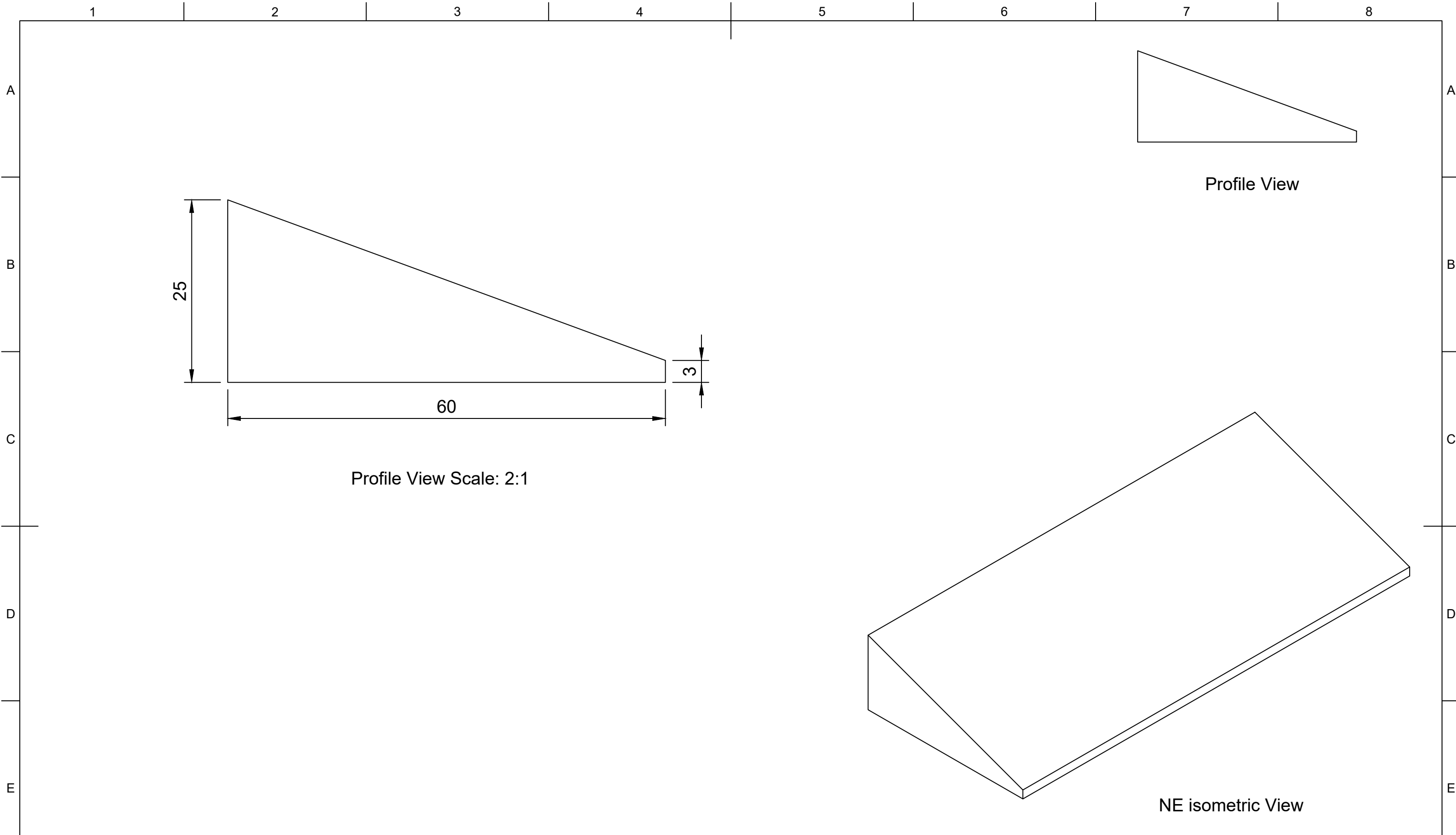

Profile View Scale: 2:1

Profile View

NE isometric View



	<b>Part Number</b>				<b>Created By</b>		<b>Cross Sectional Area (mm<sup>2</sup>)</b>		<b>Nominal Dimension (mm)</b>		<b>Tolerance, ± (mm)</b>
	208608				Isaac Erskine		840		<b>Greater Than</b>	<b>Less Than or Equal to</b>	
	<b>Description</b>				<b>Date Drawn</b>		<b>Material</b>		0.00		0.40
	Wedge (Lipped)				24/09/2020		EPDM		1.50		0.50
	<b>Revision</b>				<b>Approved By</b>		<b>Hardness (Shore A)</b>		2.50		0.70
	A	<b>Date of Issue</b>		<b>Sheet Scale</b>	<b>Sheet Size</b>	<b>Sheet</b>	Isaac Erskine		4.00		0.80
		21/02/2022		1:1	A3	1/1	21/02/2022		6.30		1.00
							<b>Date of Approval</b>		10.00		1.30
							21/02/2022		16.00		1.60
							<b>Projection</b>		25.00		2.00
						3rd Agl.		40.00		2.50	
						<b>Weight (g/m)</b>		63.00		3.20	
						1.277		100.00		3.20%	

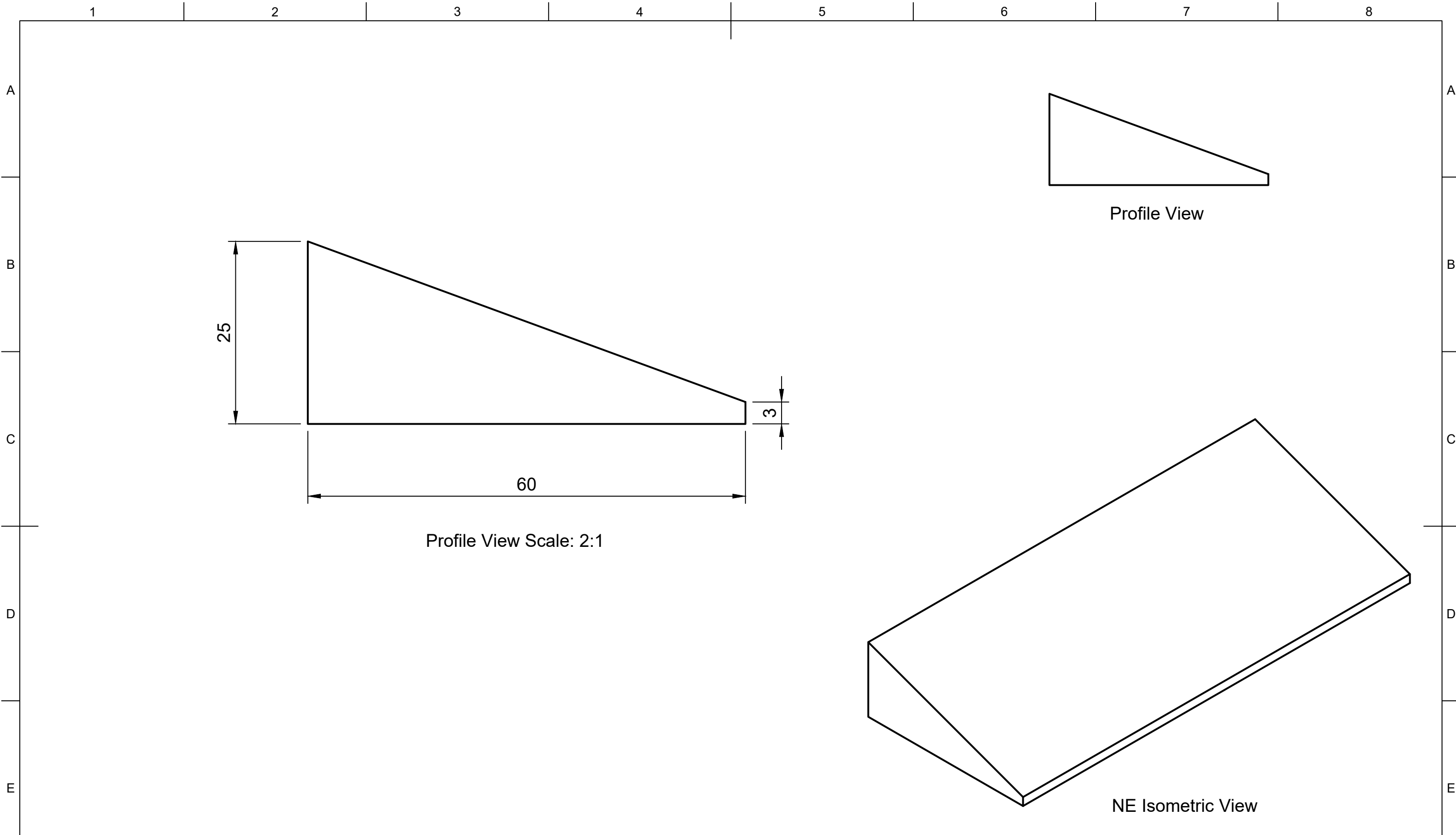

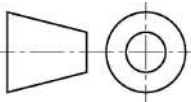
	<b>Part Number</b>				<b>Created By</b>		<b>Cross Sectional Area (mm<sup>2</sup>)</b>		<b>Nominal Dimension (mm)</b>		<b>Tolerance, ± (mm)</b>
	209680				Isaac Erskine		840		<b>Greater Than</b>	<b>Less Than or Equal to</b>	
	<b>Description</b>				<b>Date Drawn</b>		<b>Material</b>		0.00		0.40
	Wedge (Lipped)				21/02/2022		Neoprene		1.50		0.50
	<b>Revision</b>				<b>Approved By</b>		<b>Hardness (Shore A)</b>		2.50		0.70
	A	21/02/2022		Isaac Erskine		70		4.00		0.80	
	<b>Date of Issue</b>				<b>Date of Approval</b>		<b>Colour</b>		6.30		1.00
	<b>Sheet Scale</b>				21/02/2022		Black		10.00		1.30
	<b>Sheet Size</b>				<b>Projection</b>		<b>Weight (g/m)</b>		16.00		1.60
	A3				3rd Agl. 		1.277		25.00		2.00
1/1								40.00		2.50	
								63.00		3.20	
								100.00		3.20%	

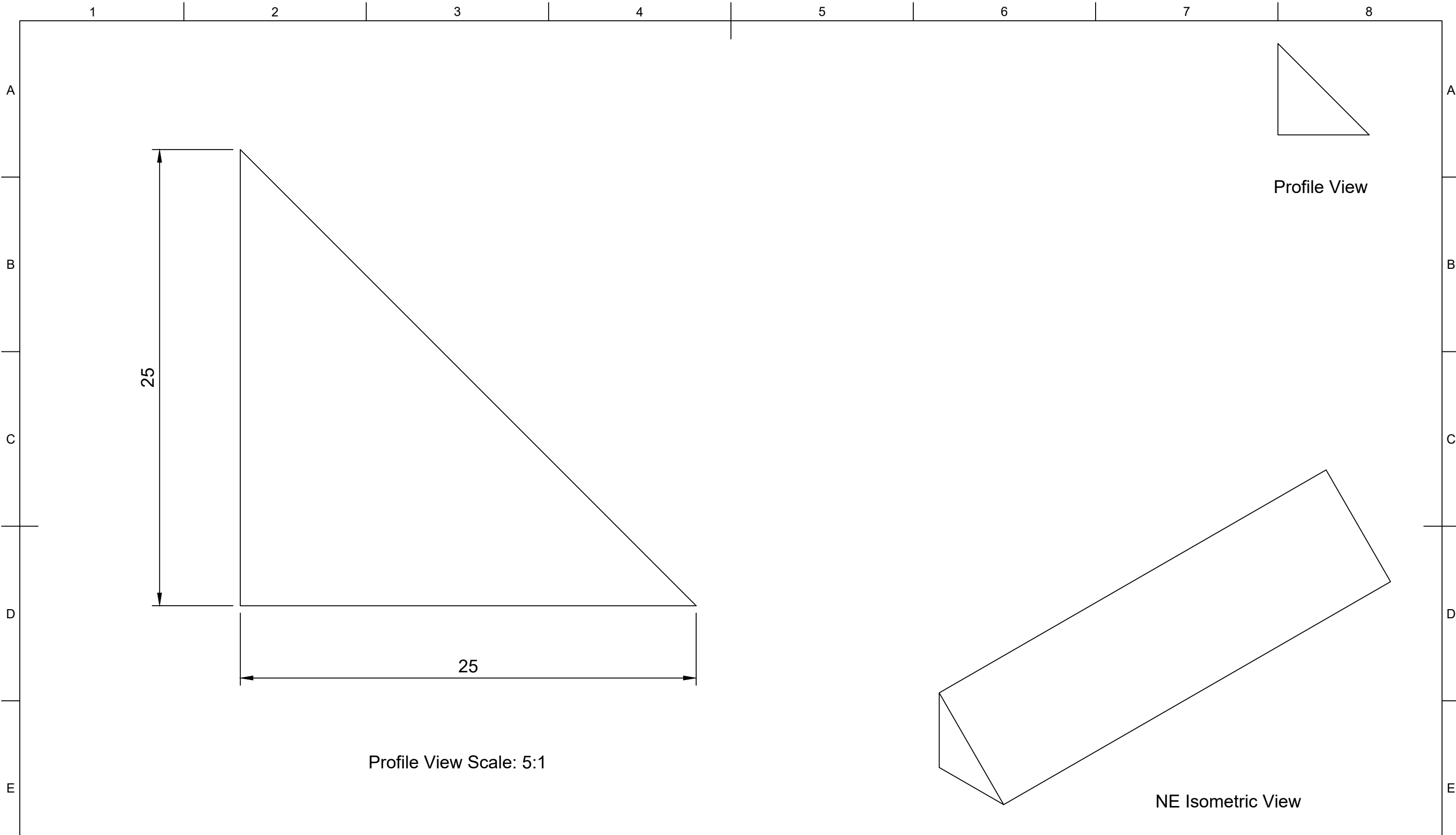

	<b>Part Number</b>				<b>Created By</b>		<b>Cross Sectional Area (mm<sup>2</sup>)</b>		<b>Nominal Dimension (mm)</b>		<b>Tolerance, ± (mm)</b>
	205972				Isaac Erskine		313		<b>Greater Than</b>	<b>Less Than or Equal to</b>	
	<b>Description</b>				<b>Date Drawn</b>		<b>Material</b>		0.00	1.50	0.40
	Wedge				16/09/2020		EPDM		1.50	2.50	0.50
	<b>Revision</b>				<b>Approved By</b>		<b>Hardness (Shore A)</b>		2.50	4.00	0.70
	A	21/02/2022		Isaac Erskine		70		4.00	6.30	0.80	
	<b>Date of Issue</b>		<b>Sheet Scale</b>		<b>Date of Approval</b>		<b>Colour</b>		6.30	10.00	1.00
	21/02/2022		1:1		21/02/2022		Black		10.00	16.00	1.30
	<b>Sheet Size</b>		<b>Sheet</b>		<b>Projection</b>		<b>Weight (g/m)</b>		16.00	25.00	1.60
	A3		1/1		3rd Agl.		394		25.00	40.00	2.00
								40.00	63.00	2.50	
								63.00	100.00	3.20	
								100.00		3.20%	