

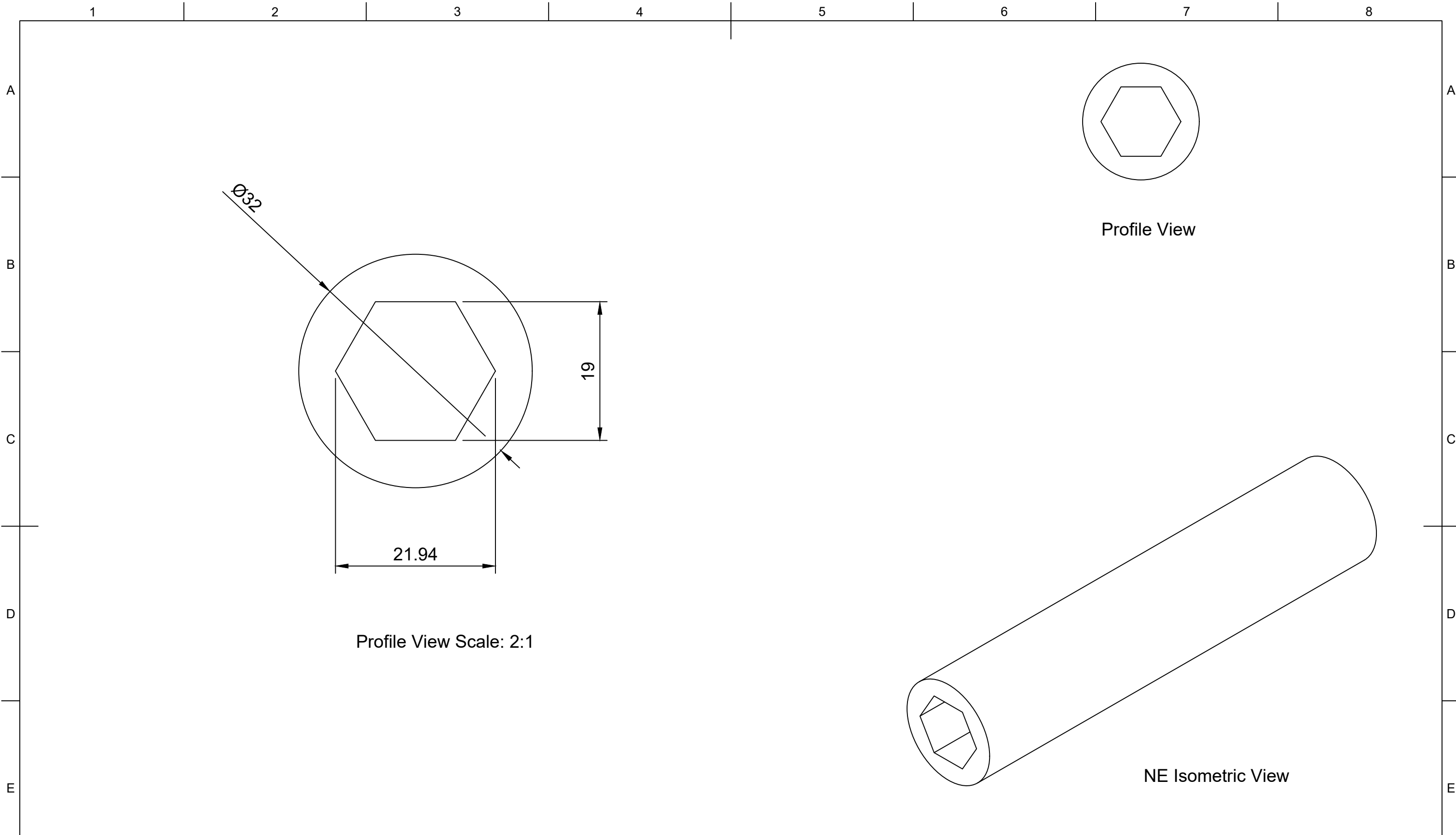





Tubes



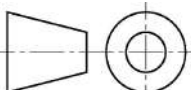
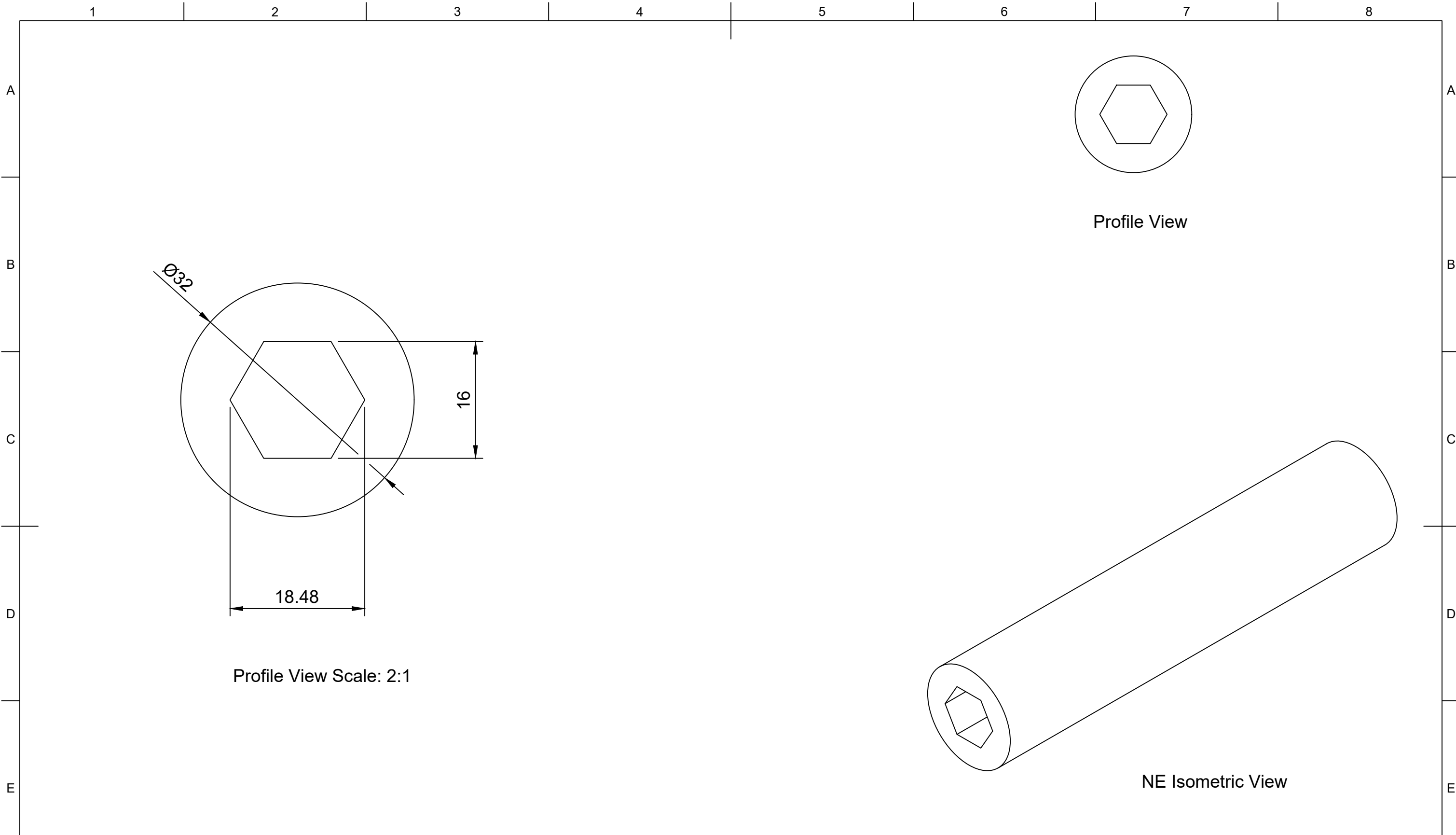

	Part Number				Created By		Cross Sectional Area (mm²)		Nominal Dimension (mm)		Tolerance, ± (mm)	
	201445				David Stirling		492		Greater Than	Less Than or Equal to		
	Description				Date Drawn		Material		0.00	1.50	0.40	
	Tube - Hexagonal Centre				28/06/2020		EPDM		1.50	2.50	0.50	
	Revision				Approved By		Hardness (Shore A)		2.50	4.00	0.70	
	A	Date of Issue		Sheet Scale	Sheet Size	Sheet	Date of Approval		4.00	6.30	0.80	
		26/01/2022		1:1	A3	1/1	3rd Agl. 		6.30	10.00	1.00	
		Projection				Colour		Weight (g/m)		10.00	16.00	1.30
						Black		620		16.00	25.00	1.60
										25.00	40.00	2.00
									40.00	63.00	2.50	
									63.00	100.00	3.20	
									100.00		3.20%	



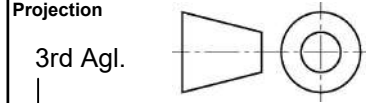

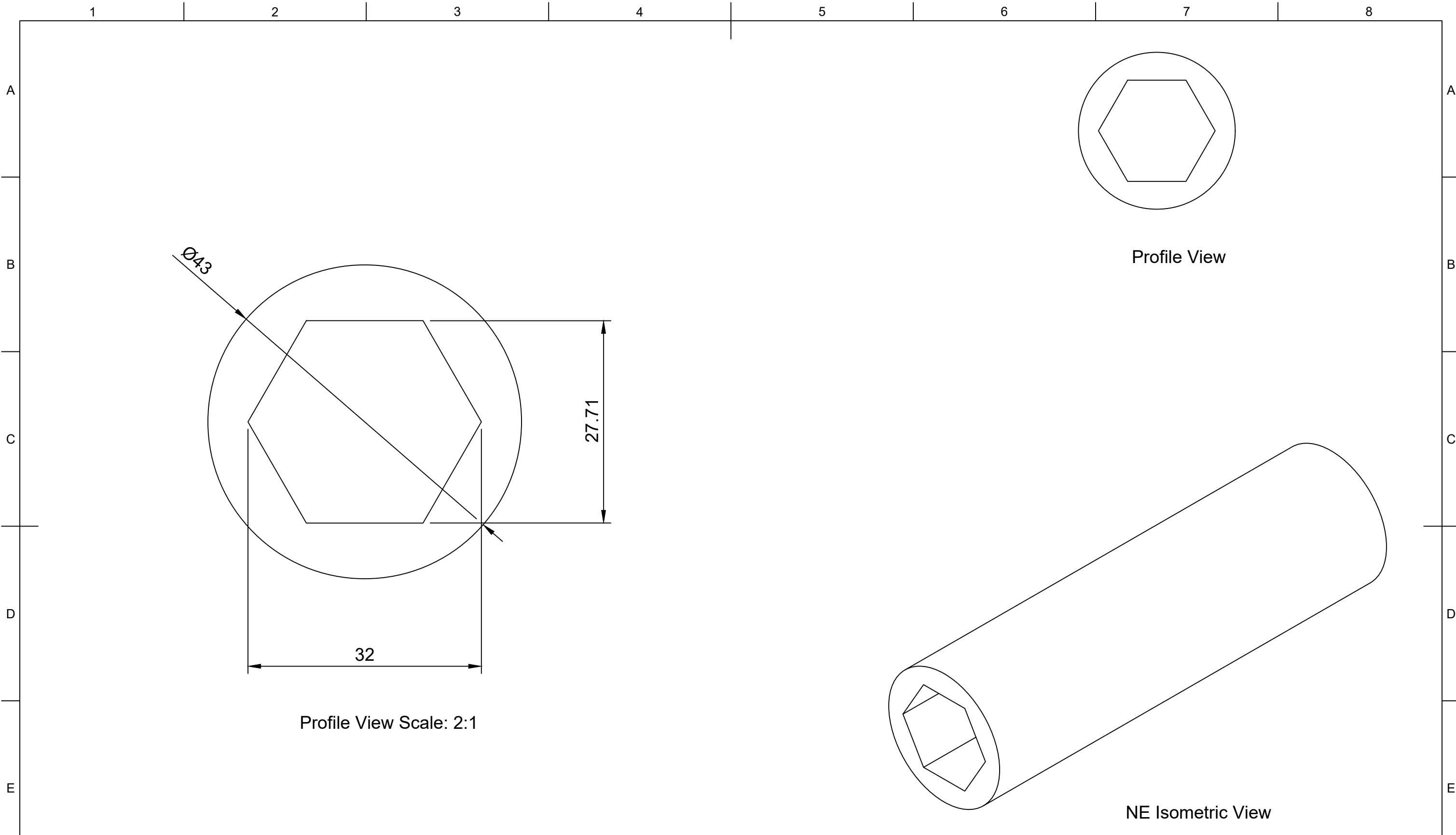
	Part Number				Created By		Cross Sectional Area (mm²)		Nominal Dimension (mm)		Tolerance, ± (mm)	
	203167				David Stirling		583		Greater Than	Less Than or Equal to		
	Description				Date Drawn		Material		0.00	1.50	0.40	
	Tube - Hexagonal Centre				28/06/2020		EPDM		1.50	2.50	0.50	
	Revision				Approved By		Hardness (Shore A)		2.50	4.00	0.70	
	A	26/01/2022		Sheet Scale		Date of Approval		70		4.00	6.30	0.80
		26/01/2022		1:1		Date of Approval		Black		6.30	10.00	1.00
		26/01/2022		A3		Date of Approval		735		10.00	16.00	1.30
		26/01/2022		1/1		Date of Approval		735		16.00	25.00	1.60
		26/01/2022		1/1		Date of Approval		735		25.00	40.00	2.00
	26/01/2022		1/1		Date of Approval		735		40.00	63.00	2.50	
	26/01/2022		1/1		Date of Approval		735		63.00	100.00	3.20	
	26/01/2022		1/1		Date of Approval		735		100.00	---	3.20%	



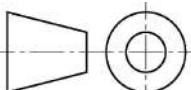

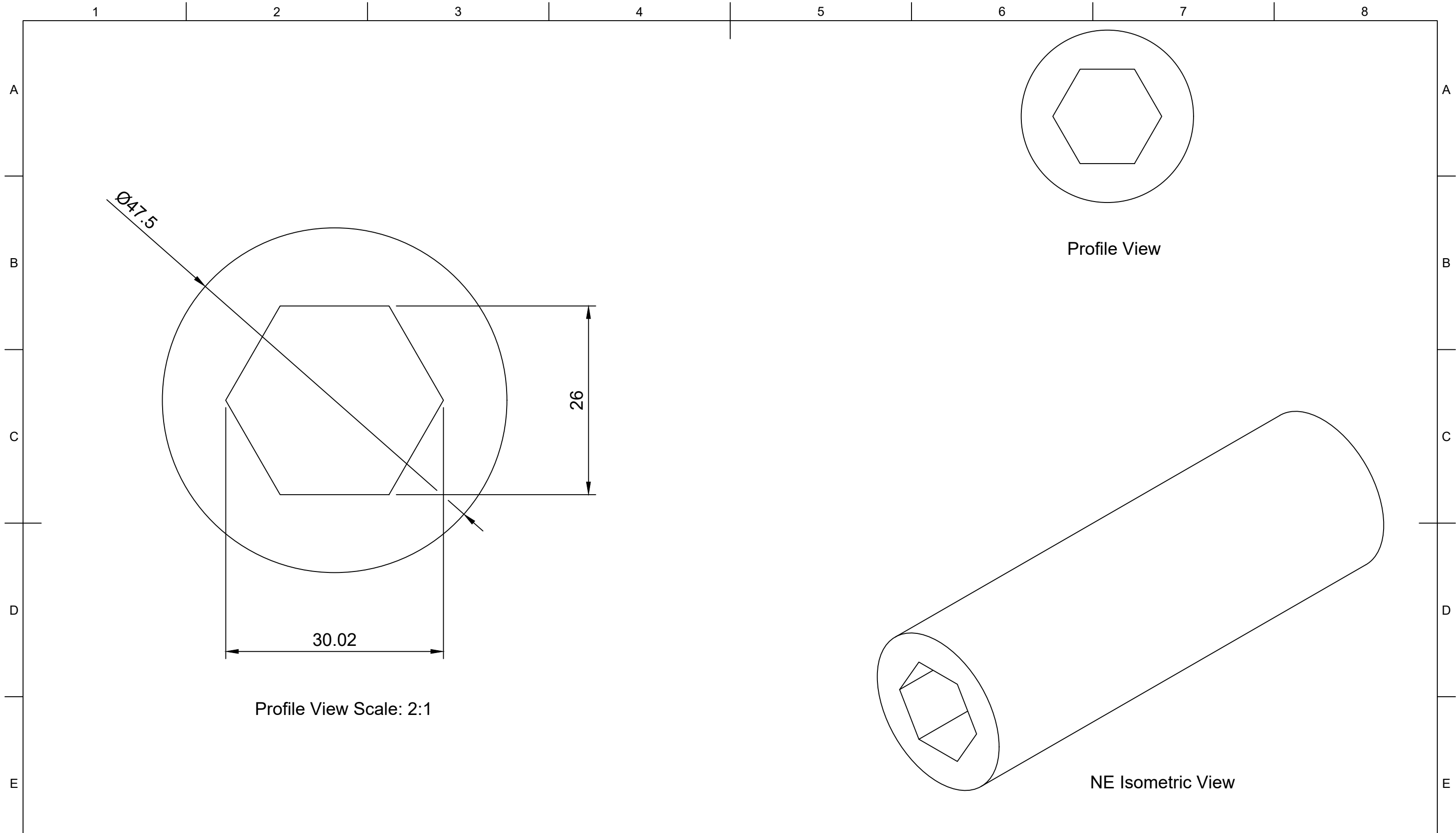
	Part Number				Created By		Cross Sectional Area (mm²)		Nominal Dimension (mm)		Tolerance, ± (mm)
	204749				David Stirling		787		Greater Than	Less Than or Equal to	
	Description				Date Drawn		Material		0.00	1.50	0.40
	Tube - Hexagonal Centre				28/06/2020		EPDM		1.50	2.50	0.50
	Revision				Approved By		Hardness (Shore A)		2.50	4.00	0.70
	A	Date of Issue		Sheet Scale	Sheet Size	Sheet	Date of Approval		4.00	6.30	0.80
		26/01/2022		1:1	A3	1/1	Projection		6.30	10.00	1.00
							3rd Ang. 		10.00	16.00	1.30
							Weight (g/m)		16.00	25.00	1.60
							992		25.00	40.00	2.00
								40.00	63.00	2.50	
								63.00	100.00	3.20	
								100.00		3.20%	

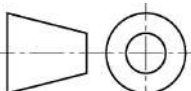

	Part Number				Created By		Cross Sectional Area (mm²)		Nominal Dimension (mm)		Tolerance, ± (mm)								
	206639				David Stirling		1187		Greater Than	Less Than or Equal to									
	Description				Date Drawn		Material		0.00	1.50	0.40								
					28/06/2020		EPDM		1.50	2.50	0.50								
	Tube - Hexagonal Centre				Approved By		Hardness (Shore A)		2.50	4.00	0.70								
					Date of Approval		70		4.00	6.30	0.80								
							Colour		6.30	10.00	1.00								
	Revision A				Date of Issue 26/01/2022		Sheet Scale 1:1		Sheet Size A3		Sheet 1/1		Projection 3rd Agl. 		Weight (kg/m) 1.496		10.00	16.00	1.30
																	16.00	25.00	1.60
																	25.00	40.00	2.00
40.00																	63.00	2.50	
								63.00	100.00	3.20									
								100.00		3.20%									

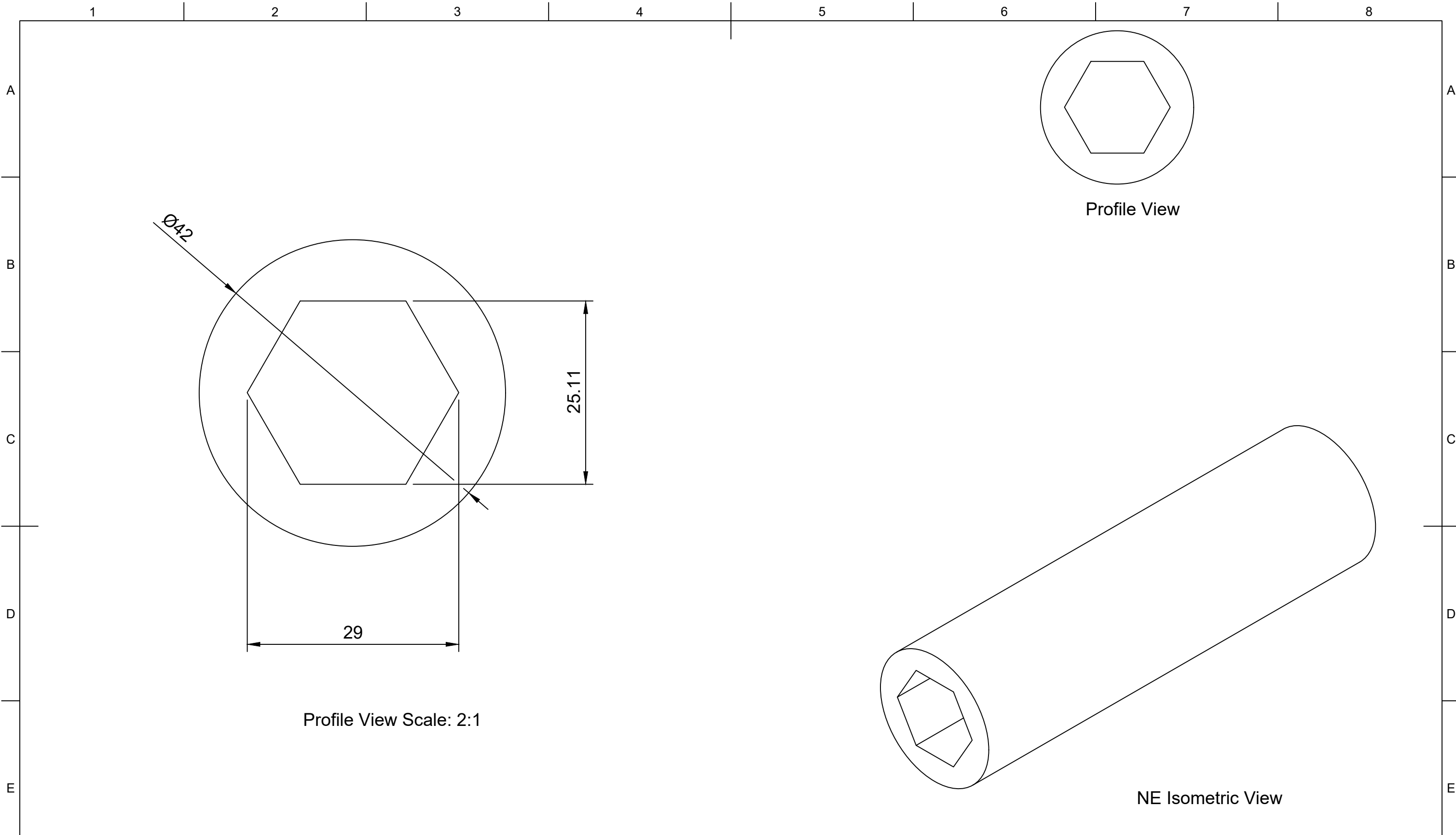

	Part Number				Created By		Cross Sectional Area (mm²)		Nominal Dimension (mm)		Tolerance, ± (mm)	
	208647				David Stirling		839		Greater Than	Less Than or Equal to		
					Date Drawn		Material		0.00	1.50	0.40	
					28/06/2020		EPDM		1.50	2.50	0.50	
	Description				Approved By		Hardness (Shore A)		2.50	4.00	0.70	
	Tube - Hexagonal Centre						70		4.00	6.30	0.80	
					Date of Approval		Colour		6.30	10.00	1.00	
							Black		10.00	16.00	1.30	
							Weight (kg/m)		16.00	25.00	1.60	
							1.057		25.00	40.00	2.00	
Revision	Date of Issue	Sheet Scale	Sheet Size	Sheet	Projection			40.00	63.00	2.50		
A	26/01/2022	1:1	A3	1/1	3rd Agl.			63.00	100.00	3.20		
								100.00	---	3.20%		

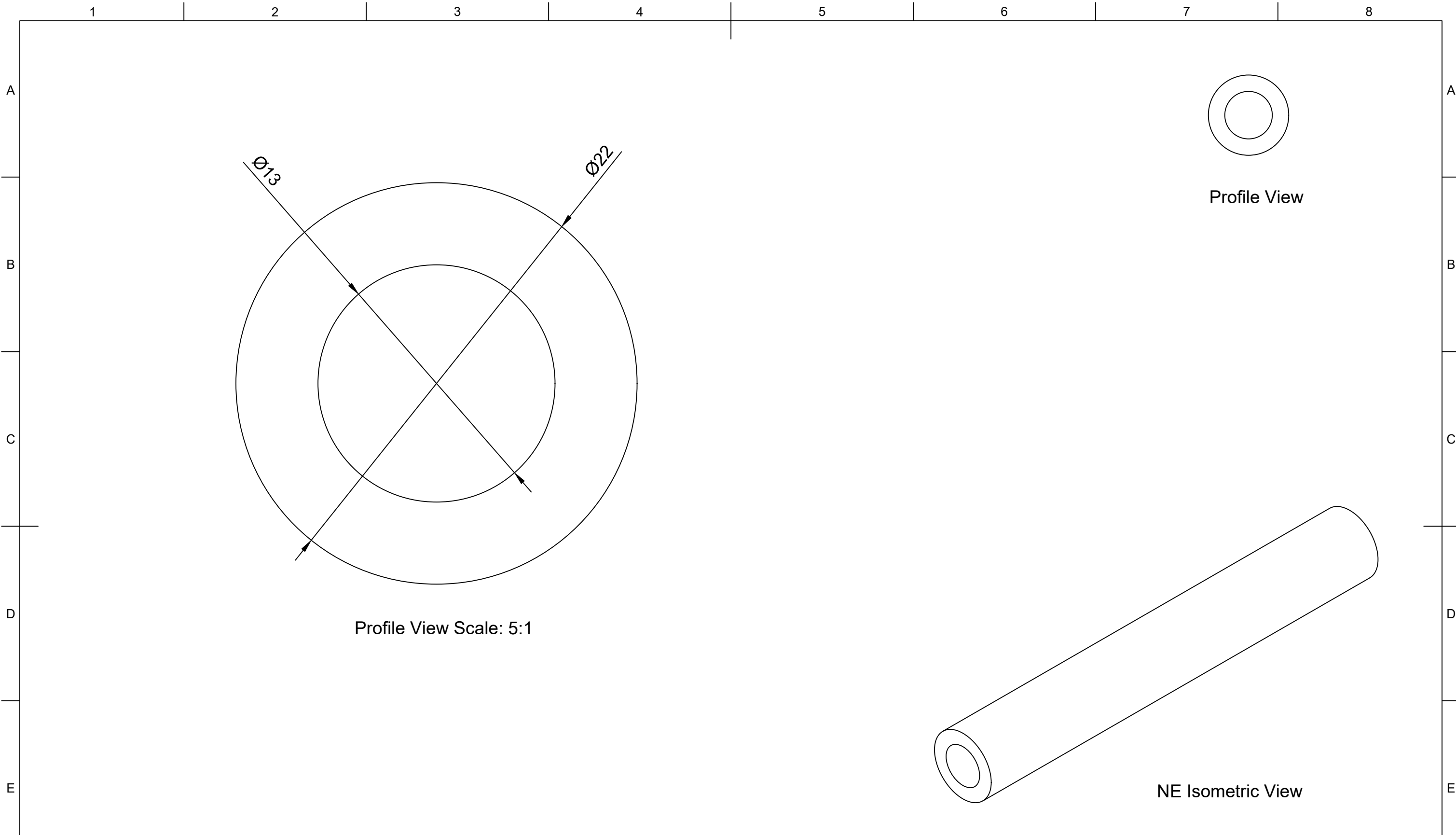

	Part Number				Created By		Cross Sectional Area (mm²)		Nominal Dimension (mm)		Tolerance, ± (mm)
	207638				Isaac Erskine		247		Greater Than	Less Than or Equal to	
	Description				Date Drawn		Material		0.00	1.50	0.40
	Tube				23/09/2020		EPDM		1.50	2.50	0.50
	Revision				Approved By		Hardness (Shore A)		2.50	4.00	0.70
	A	Date of Issue		Sheet Scale	Sheet Size	Sheet	Isaac Erskine		4.00	6.30	0.80
		01/03/2022		1:1	A3	1/1	Date of Approval		6.30	10.00	1.00
							01/03/2022		10.00	16.00	1.30
							Projection		16.00	25.00	1.60
							3rd Agl.		25.00	40.00	2.00
						Weight (g/m)		40.00	63.00	2.50	
						311		63.00	100.00	3.20	
								100.00		3.20%	