

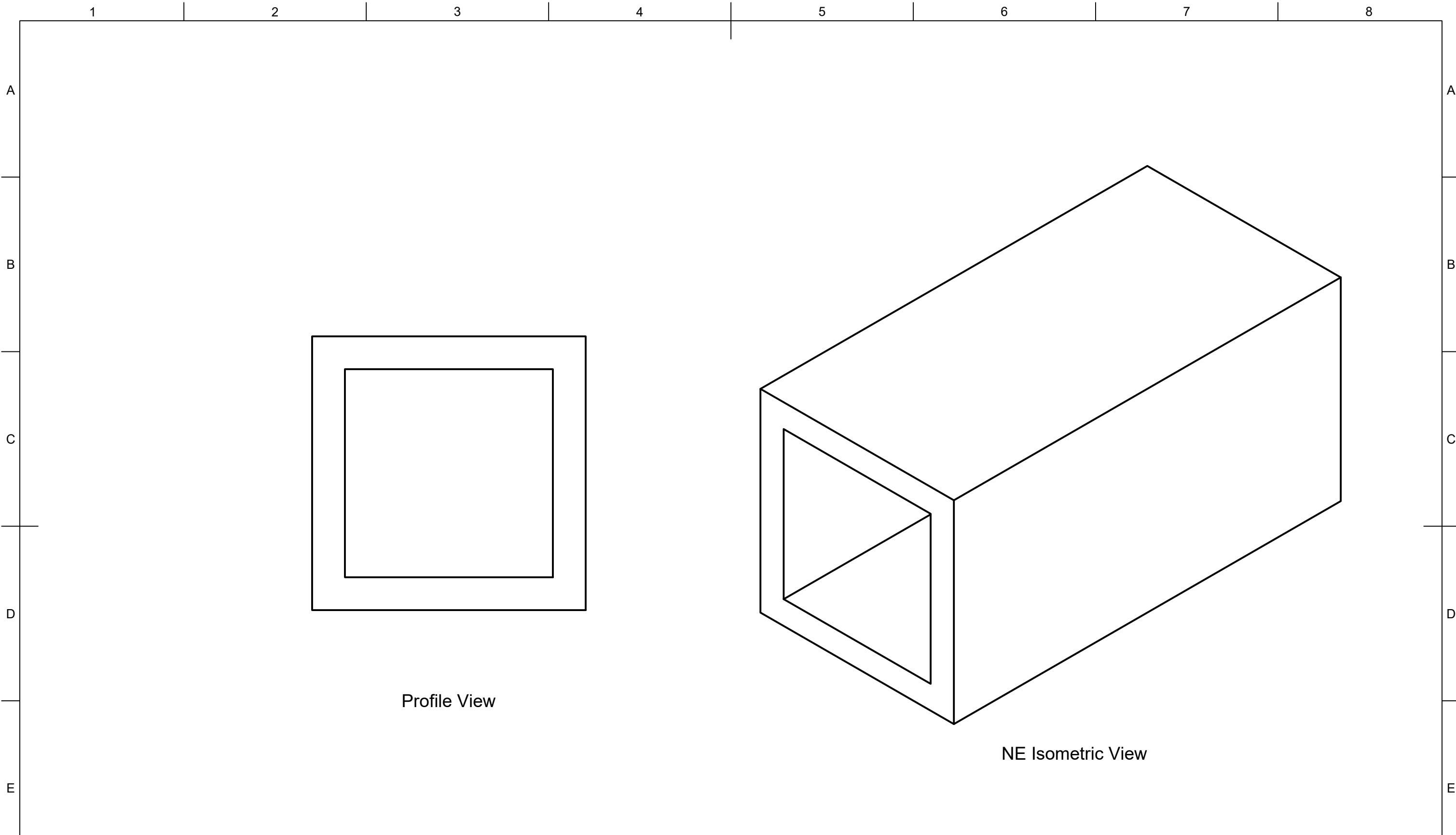



Squares



Profile View

NE Isometric View

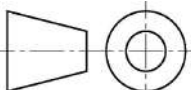
	Part Number				Created By		Cross Sectional Area (mm²)		Nominal Dimension (mm)		Tolerance, ± (mm)
	201806				David Stirling		2376		Greater Than	Less Than or Equal to	
	Description				Date Drawn		Material		0.00	1.50	0.40
	Square - Hollow				26/01/2022		Neoprene		1.50	2.50	0.50
	Revision				Approved By		Hardness (Shore A)		2.50	4.00	0.70
	A	Date of Issue		Sheet Scale	Sheet Size	Sheet	Date of Approval		4.00	6.30	0.80
		26/01/2022		1:1	A3	1/1	3rd Agl. 		6.30	10.00	1.00
							Weight (kg/m)		10.00	16.00	1.30
							3.612		16.00	25.00	1.60
									25.00	40.00	2.00
								40.00	63.00	2.50	
								63.00	100.00	3.20	
								100.00		3.20%	

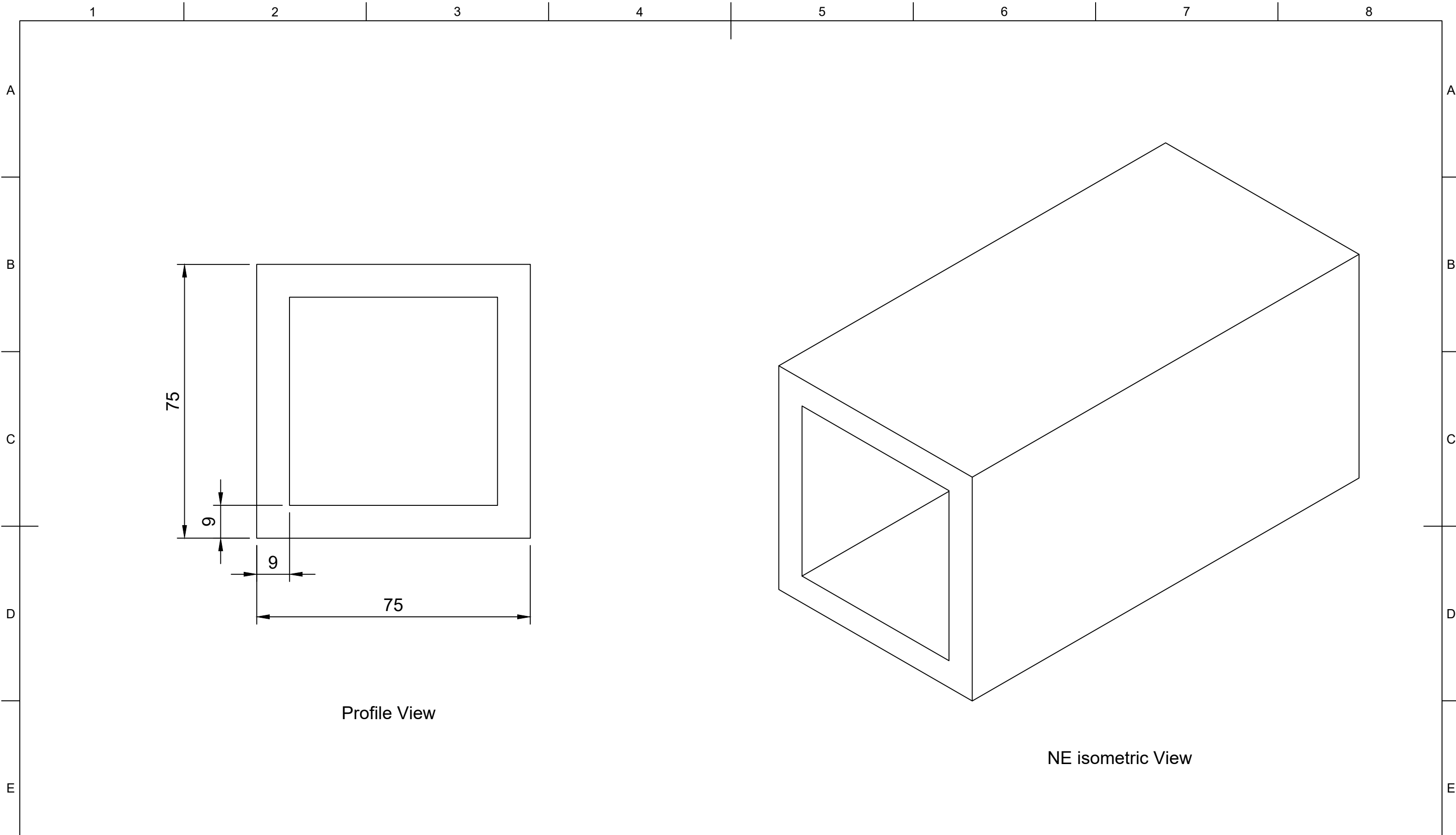

Profile View

NE isometric View

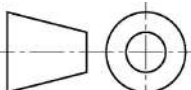
	Part Number				Created By		Cross Sectional Area (mm²)		Nominal Dimension (mm)		Tolerance, ± (mm)
	206428				David Stirling		2376		Greater Than	Less Than or Equal to	
	Description				Date Drawn		Material		0.00	1.50	0.40
					23/06/2020		EPDM		1.50	2.50	0.50
	Square - Hollow				Approved By		Hardness (Shore A)		2.50	4.00	0.70
					Date of Approval		70		4.00	6.30	0.80
							Black		6.30	10.00	1.00
	Revision	Date of Issue	Sheet Scale	Sheet Size	Sheet	Projection	Weight (kg/m)		10.00	16.00	1.30
	A	26/01/2022	1:1	A3	1/1	3rd Agl. 	2.994		16.00	25.00	1.60
									25.00	40.00	2.00
								40.00	63.00	2.50	
								63.00	100.00	3.20	
								100.00		3.20%	

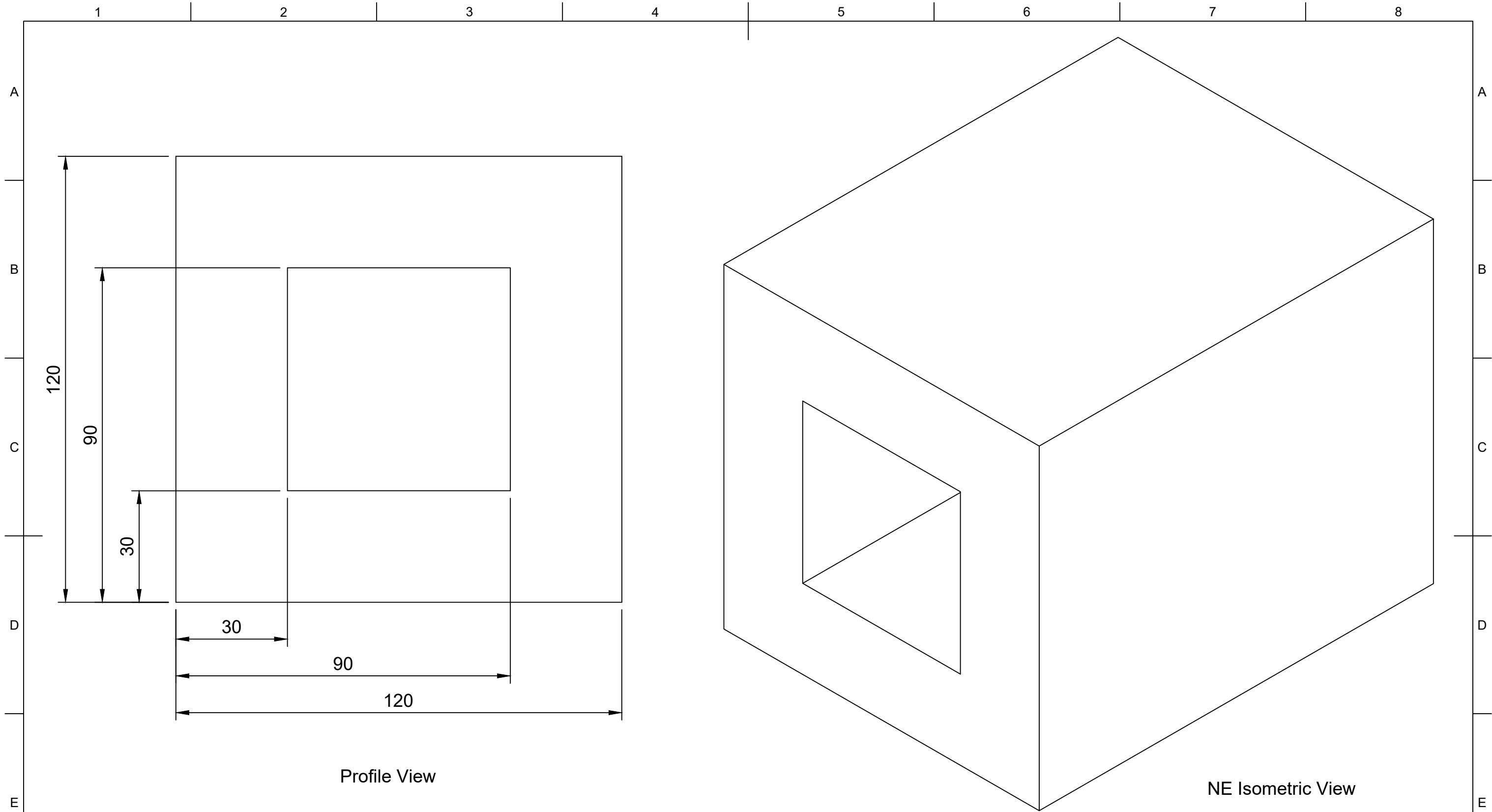

Profile View

NE Isometric View

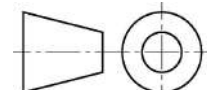
	Part Number				Created By		Cross Sectional Area (mm²)		Nominal Dimension (mm)		Tolerance, ± (mm)
	204569				Isaac Erskine		10800		Greater Than	Less Than or Equal to	
					Date Drawn		Material		0.00	1.50	0.40
					29/10/2020		EPDM		1.50	2.50	0.50
	Description				Approved By		Hardness (Shore A)		2.50	4.00	0.70
	Square - Hollow				Isaac Erskine		70		4.00	6.30	0.80
					Date of Approval		Colour		6.30	10.00	1.00
					21/02/2022		Black		10.00	16.00	1.30
									16.00	25.00	1.60
									25.00	40.00	2.00
Revision	Date of Issue	Sheet Scale	Sheet Size	Sheet	Projection	Weight (kg/m)		40.00	63.00	2.50	
A	21/02/2022	1:1	A3	1/1	3rd Agl. 	13.608		63.00	100.00	3.20	
								100.00		3.20%	

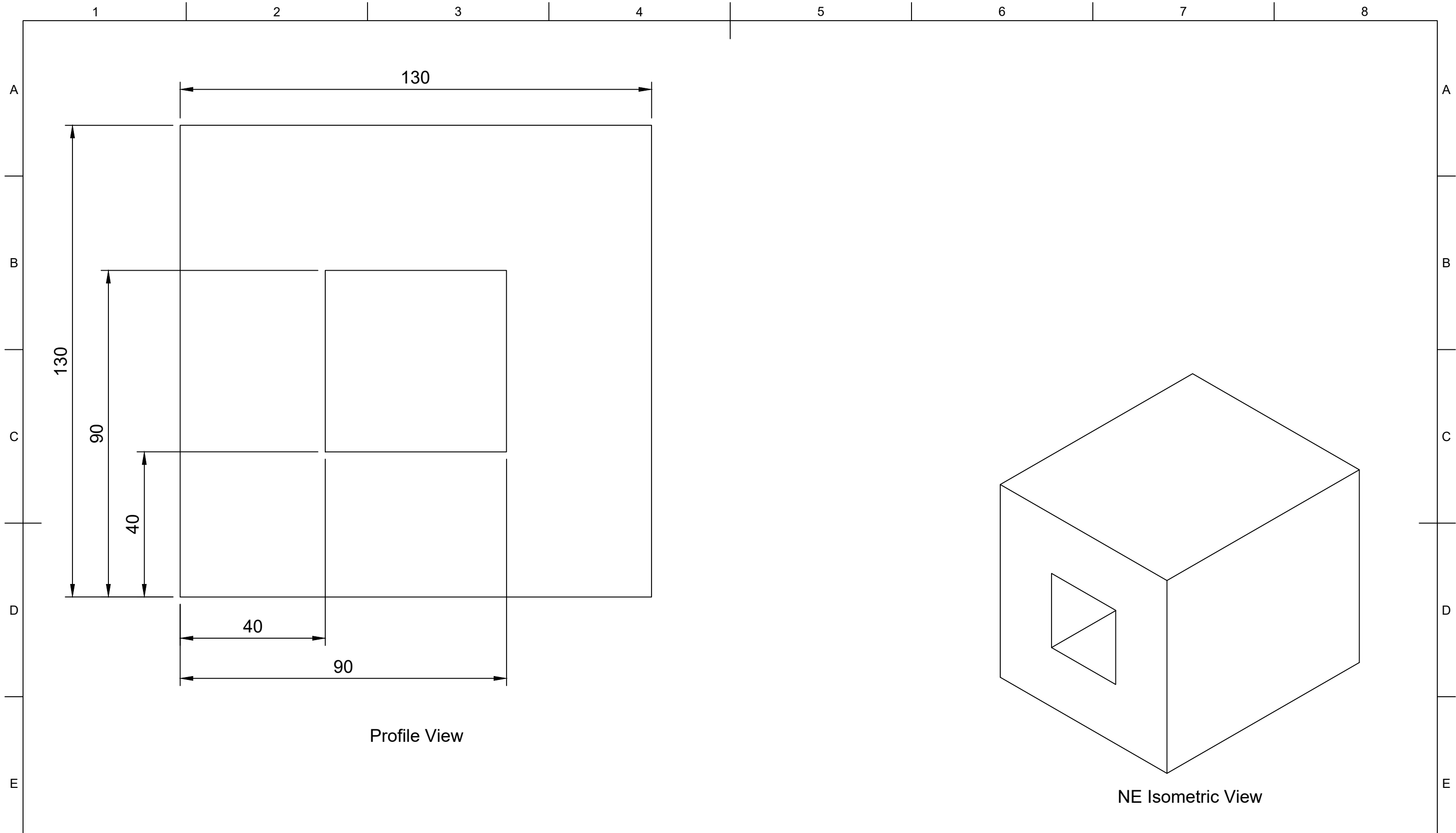

Profile View

NE Isometric View

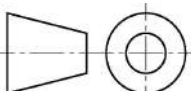
	Part Number				Created By		Cross Sectional Area (mm ²)		Nominal Dimension (mm)		Tolerance, ± (mm)
	209306				Isaac Erskine		14400		Greater Than	Less Than or Equal to	
	Description				Date Drawn		Material		0.00		0.40
	Square - Hollow				29/08/2020		EPDM		1.50		0.50
	Revision				Approved By		Hardness (Shore A)		2.50		0.70
	A	Date of Issue		Sheet Scale	Sheet Size	Sheet	70		4.00		0.80
		21/02/2022		1:1	A3	1/1	Date of Approval		6.30		1.00
							21/02/2022		10.00		1.30
							Projection		16.00		1.60
							3rd Agl. 		25.00		2.00
						Weight (kg/m)		40.00		2.50	
						18.144		63.00		3.20	
								100.00		3.20%	

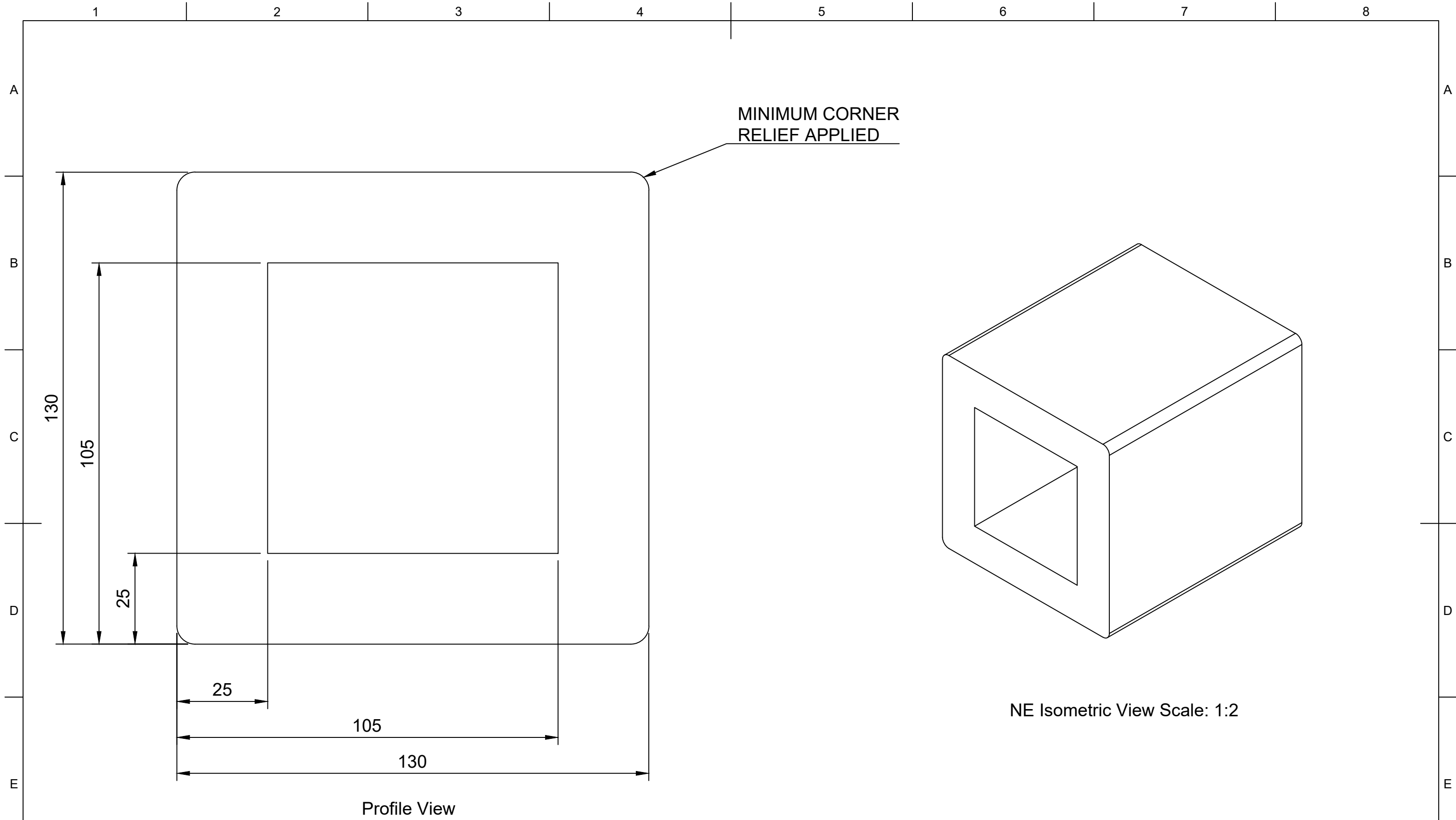

Profile View



Part Number		202584			Created By	Isaac Erskine	Cross Sectional Area (mm ²)	10479		Nominal Dimension (mm)		Tolerance, ± (mm)
					Date Drawn	29/08/2020	Material	EPDM	Greater Than	Less Than or Equal to		
Description		Square - Hollow			Approved By	Isaac Erskine	Hardness (Shore A)	70		0.00	1.50	0.40
					Date of Approval	21/02/2022	Colour	Black	1.50	2.50	0.50	
Revision	Date of Issue	Sheet Scale	Sheet Size	Sheet	Projection	3rd Agl.	Weight (g/m)	13.204		2.50	4.00	0.70
A	21/02/2022	1:1	A3	1/1			25.00	40.00	2.00			
										63.00	100.00	3.20
										100.00		3.20%

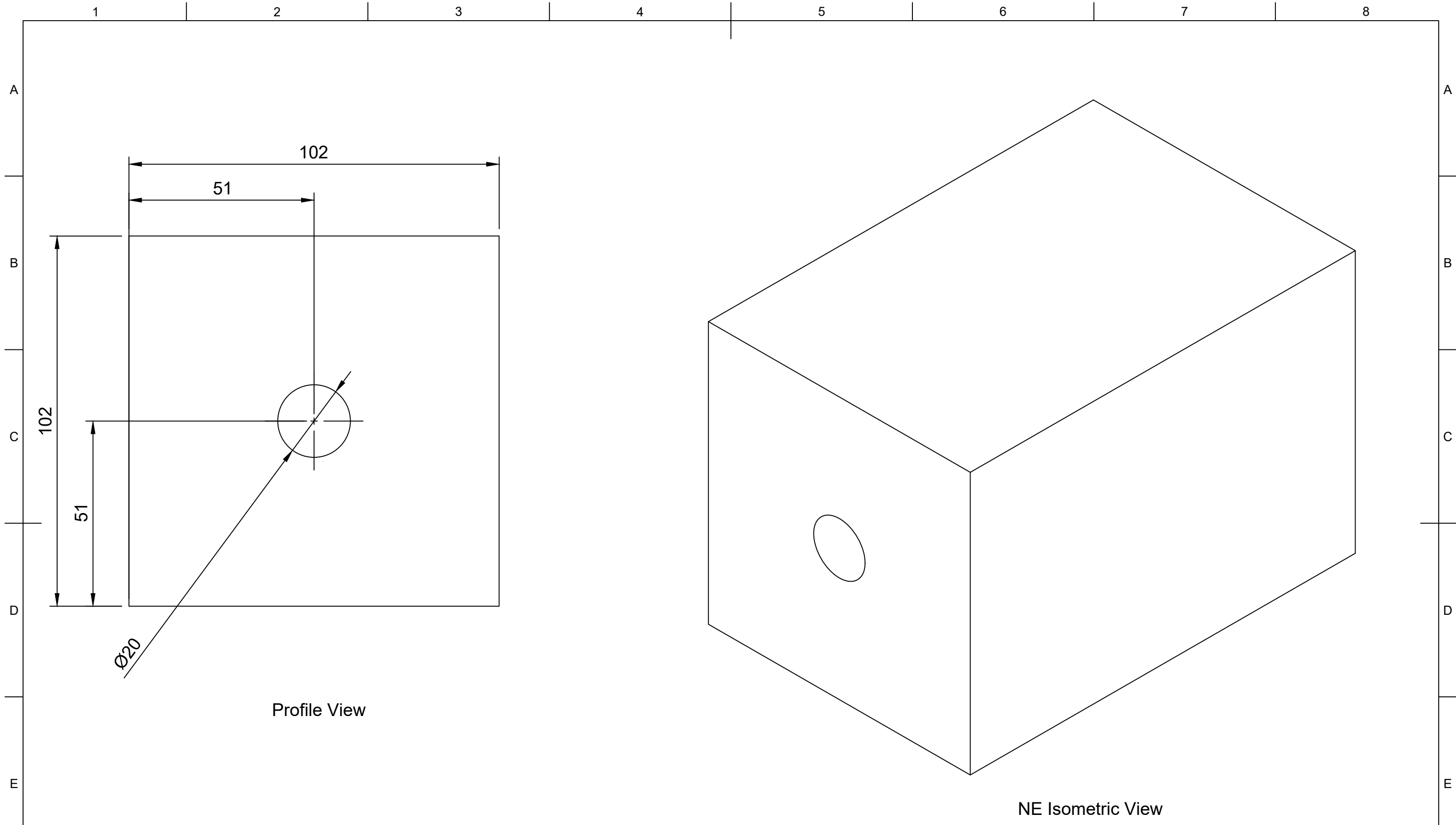

Profile View

NE Isometric View

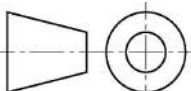
	Part Number				Created By		Cross Sectional Area (mm²)		Nominal Dimension (mm)		Tolerance, ± (mm)
	201734				Isaac Erskine		10090		Greater Than	Less Than or Equal to	
	Description				Date Drawn		Material		0.00		0.40
	Square -Round Centre				28/08/2020		EPDM		1.50		0.50
	Revision				Approved By		Hardness (Shore A)		2.50		0.70
	A	Date of Issue		Sheet Scale	Sheet Size	Sheet	Isaac Erskine		4.00		0.80
		17/02/2022		1:1	A3	1/1	17/02/2022		6.30		1.00
							Date of Approval		10.00		1.30
							17/02/2022		16.00		1.60
							Projection		25.00		2.00
						3rd Agl. 		40.00		2.50	
						Weight (kg/m)		63.00		3.20	
						12.713		100.00		3.20%	

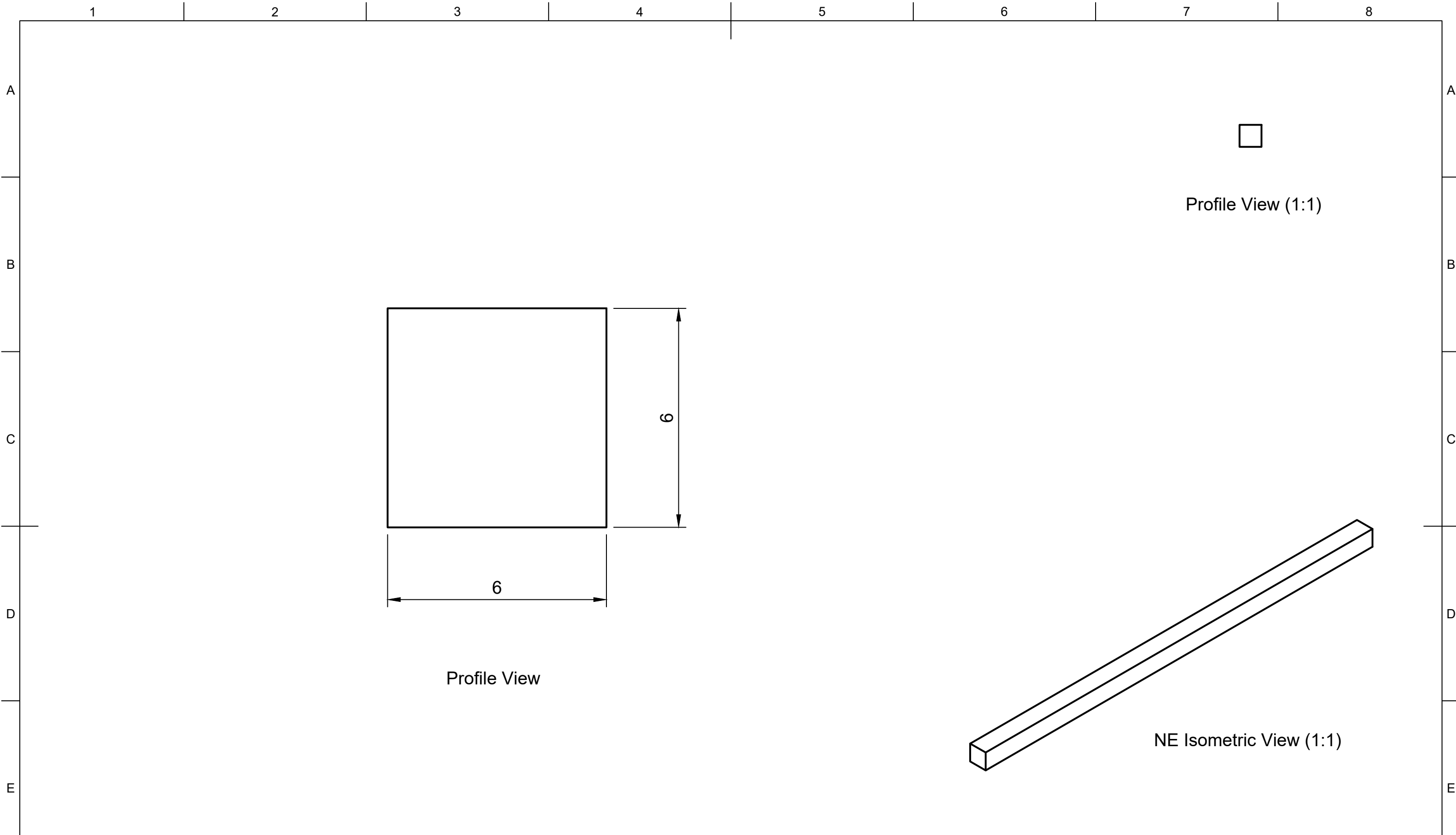

	Part Number				Created By		Cross Sectional Area (mm²)		Nominal Dimension (mm)		Tolerance, ± (mm)	
	200661				Isaac Erskine		36		Greater Than	Less Than or Equal to		
	Description				Date Drawn		Material					
	Square - Solid				19/07/2021		EPDM				0.40	
	Revision				Approved By		Hardness (Shore A)				1.50	
	A	Date of Issue		Sheet Scale		Isaac Erskine		70				2.50
		17/02/2022		10:1		17/02/2022		Black				4.00
				Sheet Size		Date of Approval		Colour				6.30
				A3		17/02/2022		Black				10.00
				Sheet		Projection		Weight (g/m)				16.00
			1/1		3rd Agl.		46				25.00	
											40.00	
											63.00	
											100.00	
											3.20%	

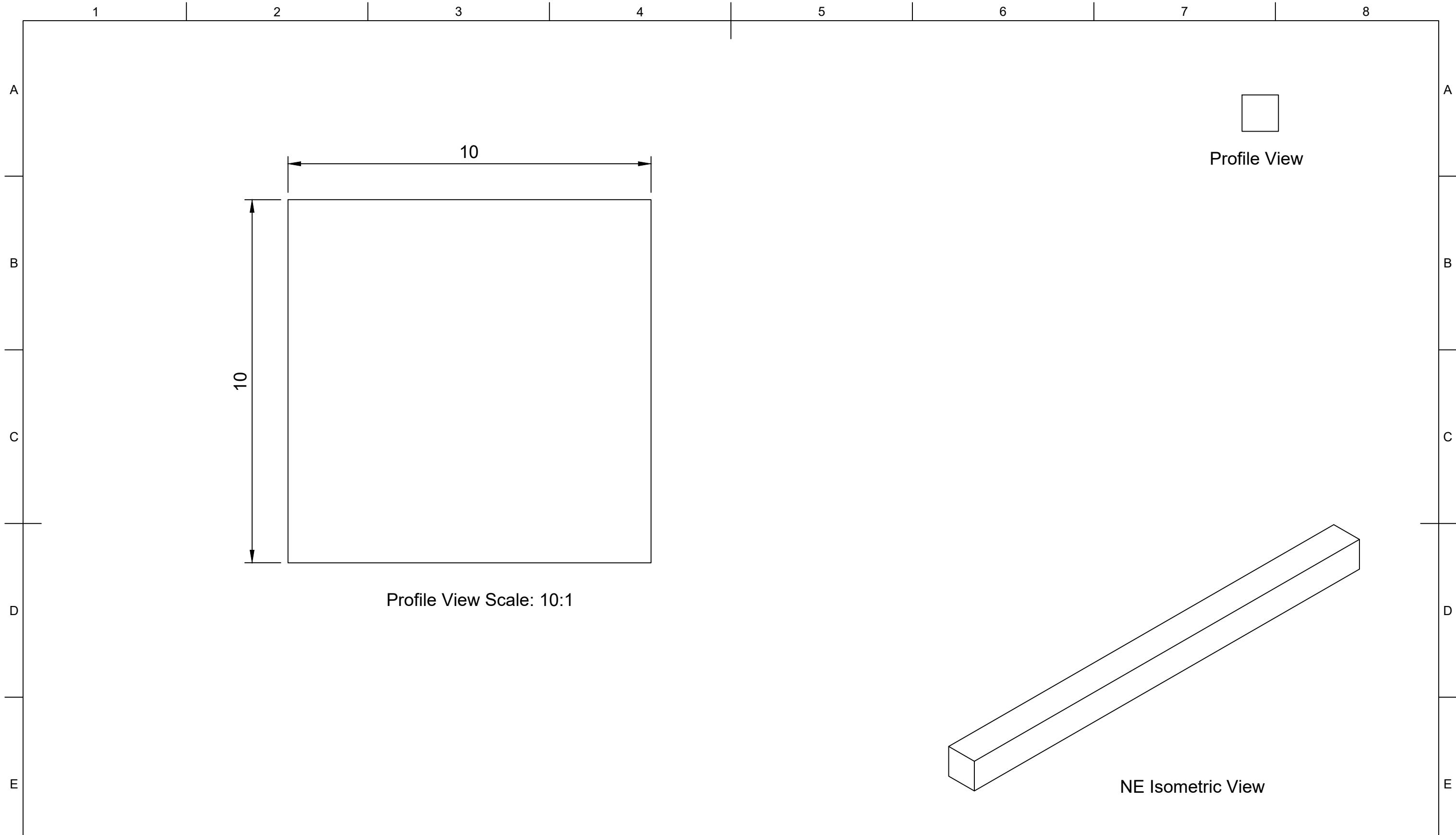

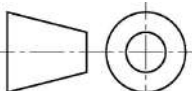
	Part Number				Created By		Cross Sectional Area (mm²)		Nominal Dimension (mm)		Tolerance, ± (mm)
	202118				Isaac Erskine		100		Greater Than	Less Than or Equal to	
	Description				Date Drawn		Material		0.00	1.50	0.40
	Square - Solid				28/08/2020		EPDM		1.50	2.50	0.50
	Revision				Approved By		Hardness (Shore A)		2.50	4.00	0.70
	A	Date of Issue			Isaac Erskine		70		4.00	6.30	0.80
		17/02/2022			17/02/2022		Colour		6.30	10.00	1.00
		Sheet Scale			Date of Approval		Black		10.00	16.00	1.30
		10:1			17/02/2022		Weight (g/m)		16.00	25.00	1.60
		Sheet Size			Projection		126		25.00	40.00	2.00
	A3			3rd Agl. 				40.00	63.00	2.50	
	1/1							63.00	100.00	3.20	
								100.00		3.20%	

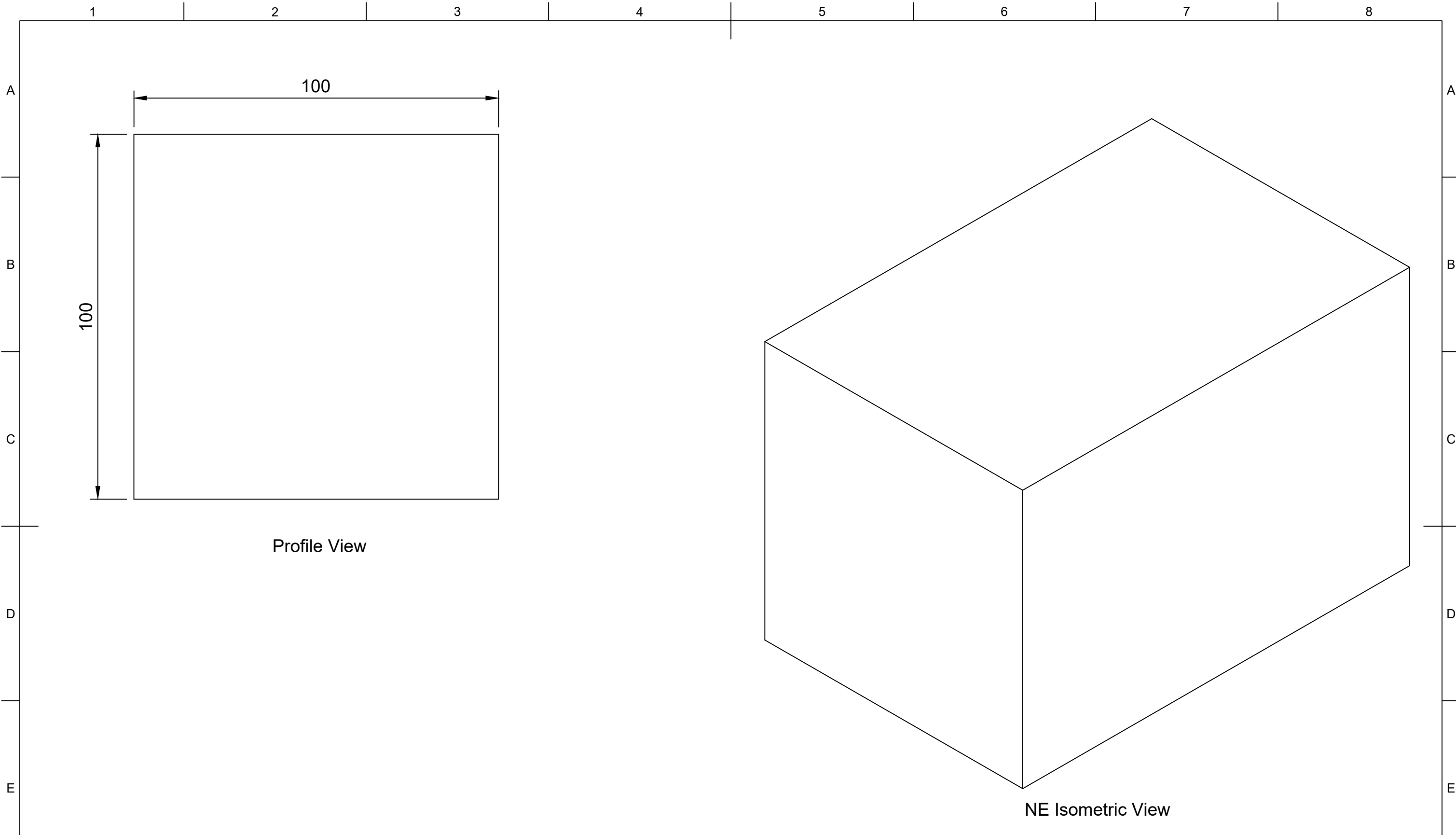



Profile View

NE Isometric View

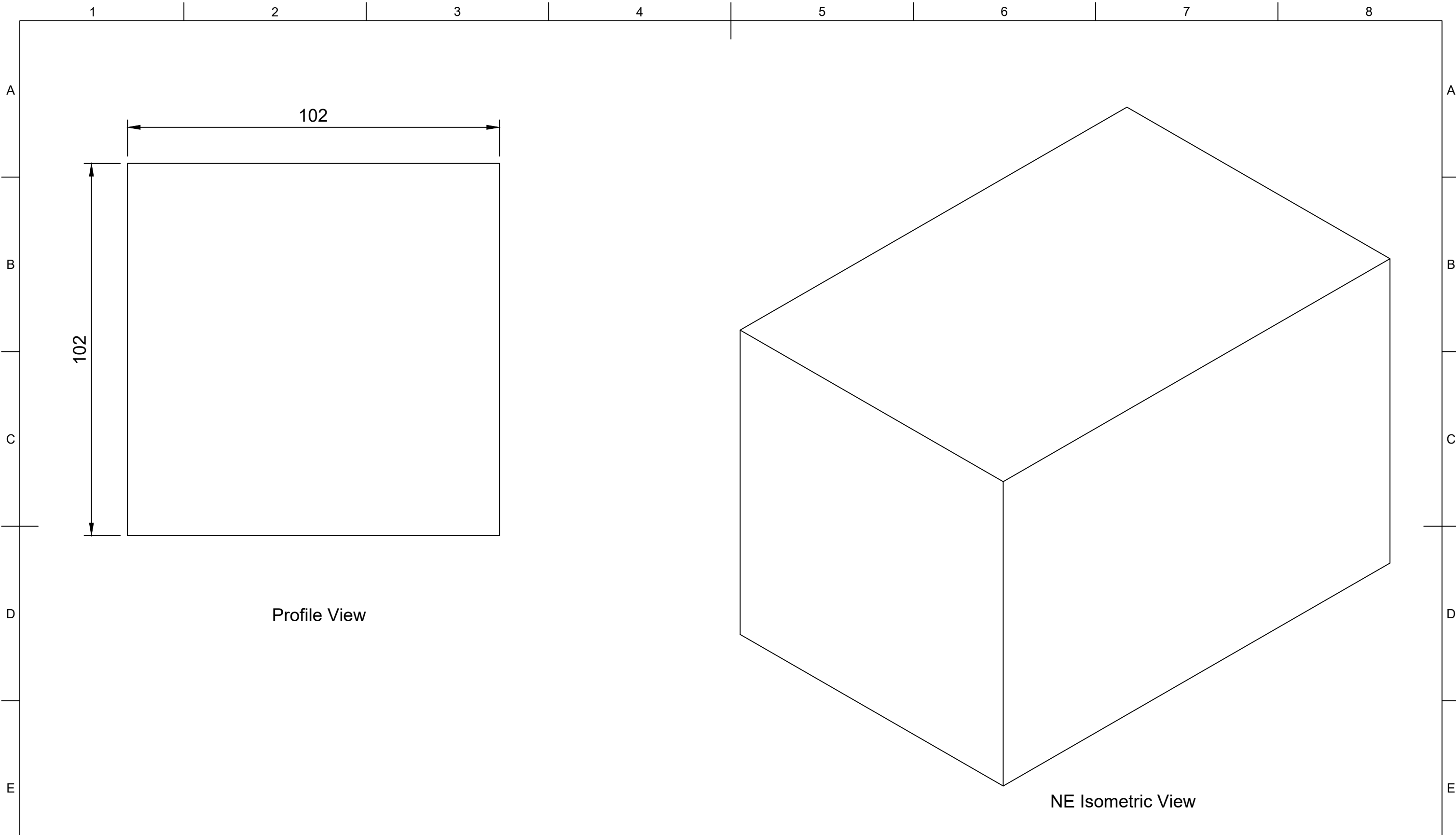

	Part Number				Created By		Cross Sectional Area (mm²)		Nominal Dimension (mm)		Tolerance, ± (mm)	
	205134				Isaac Erskine		10000		Greater Than	Less Than or Equal to		
	Description				Date Drawn		Material					
	Square - Solid				28/08/2020		EPDM					
	Revision				Approved By		Hardness (Shore A)					
	A	Date of Issue		Sheet Scale		Isaac Erskine		70				
		17/02/2022		1:1		17/02/2022		Black				
				Sheet Size		Date of Approval		Colour				
				A3		17/02/2022		Black				
				Sheet		Projection		Weight (kg/m)				
			1/1		3rd Ang.		12.6					
									25.00	40.00	2.00	
									40.00	63.00	2.50	
									63.00	100.00	3.20	
									100.00		3.20%	

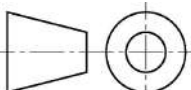

	Part Number				Created By		Cross Sectional Area (mm²)		Nominal Dimension (mm)		Tolerance, ± (mm)
	206538				Isaac Erskine		10404		Greater Than	Less Than or Equal to	
	Description				Date Drawn		Material		0.00	1.50	0.40
	Square - Solid				28/08/2020		EPDM		1.50	2.50	0.50
	Revision				Approved By		Hardness (Shore A)		2.50	4.00	0.70
	A	Date of Issue		Sheet Scale	Sheet Size	Sheet	Isaac Erskine		4.00	6.30	0.80
		17/02/2022		1:1	A3	1/1	17/02/2022		6.30	10.00	1.00
							Date of Approval		10.00	16.00	1.30
							17/02/2022		16.00	25.00	1.60
							Projection		25.00	40.00	2.00
						3rd Ang. 		40.00	63.00	2.50	
						Weight (kg/m)		63.00	100.00	3.20	
						13.109		100.00		3.20%	

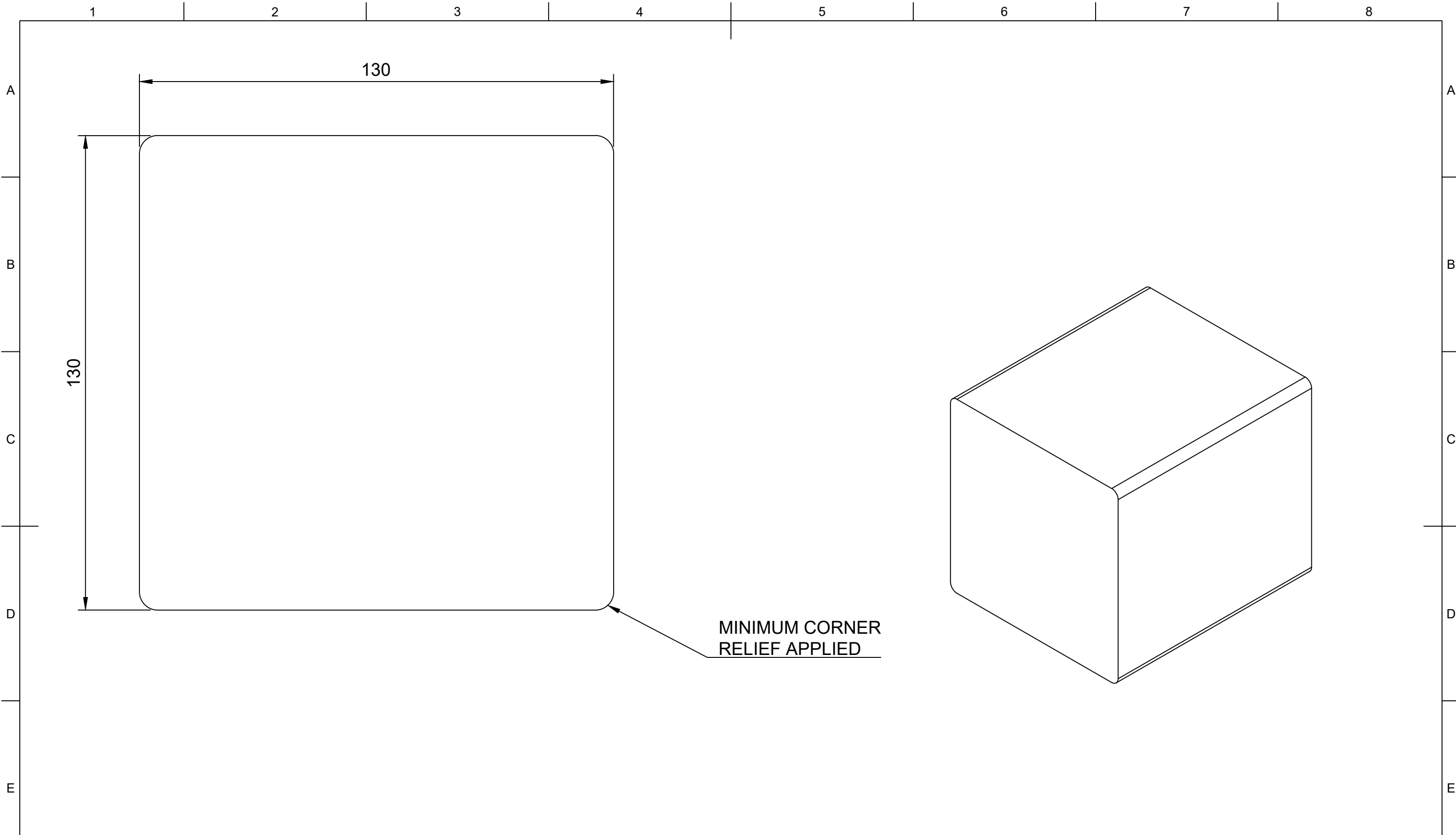

MINIMUM CORNER RELIEF APPLIED



Part Number 203364					Created By Isaac Erskine		Cross Sectional Area (mm ²) 16879		Nominal Dimension (mm)		Tolerance, ± (mm)					
					Date Drawn 29/08/2020		Material EPDM		Greater Than	Less Than or Equal to						
Description Square - Solid					Approved By Isaac Erskine		Hardness (Shore A) 70		0.00	1.50	0.40					
					Date of Approval 21/02/2022		Colour Black		1.50	2.50	0.50					
					Revision A		Date of Issue 21/02/2022	Sheet Scale 1:1	Sheet Size A3	Sheet 1/1	Projection 3rd Agl.	Weight (kg/m) 21.268		2.50	4.00	0.70
														6.30	10.00	1.00
									10.00	16.00	1.30					
									16.00	25.00	1.60					
									25.00	40.00	2.00					
									40.00	63.00	2.50					
									63.00	100.00	3.20					
									100.00		3.20%					

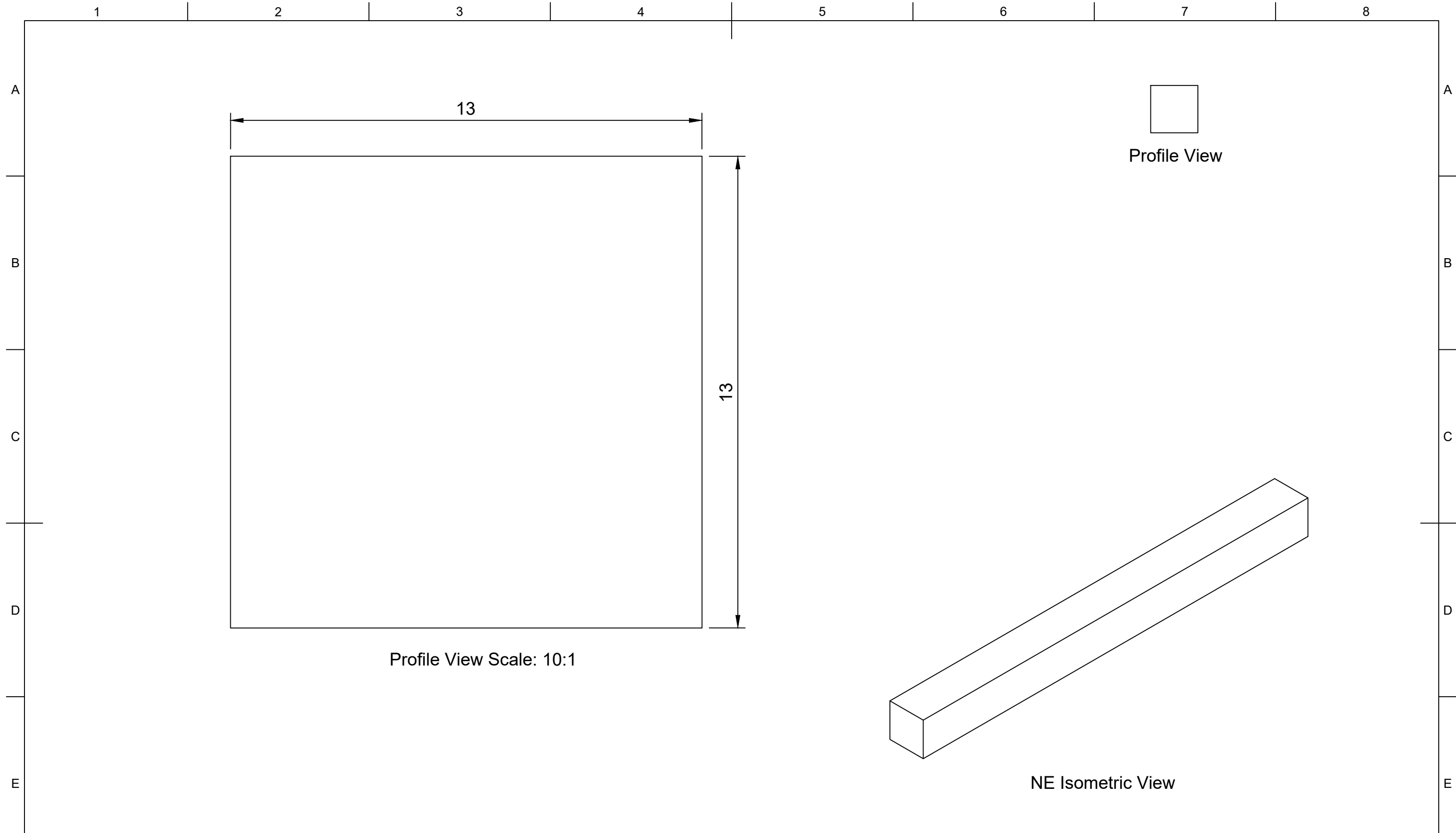

Part Number		203110			Created By	Isaac Erskine	Cross Sectional Area (mm ²)	169		Nominal Dimension (mm)		Tolerance, ± (mm)
					Date Drawn	23/07/2020	Material	EPDM	Greater Than	Less Than or Equal to		
Description		Square - Solid			Approved By	Isaac Erskine	Hardness (Shore A)	70		0.00	1.50	0.40
					Date of Approval	21/02/2022	Colour	Black	1.50	2.50	0.50	
Revision	Date of Issue	Sheet Scale	Sheet Size	Sheet	Projection	3rd Agl.	Weight (g/m)	213		2.50	4.00	0.70
A	21/02/2022	1:1	A3	1/1				6.30	10.00	1.00		
										10.00	16.00	1.30
										16.00	25.00	1.60
										25.00	40.00	2.00
										40.00	63.00	2.50
										63.00	100.00	3.20
										100.00		3.20%

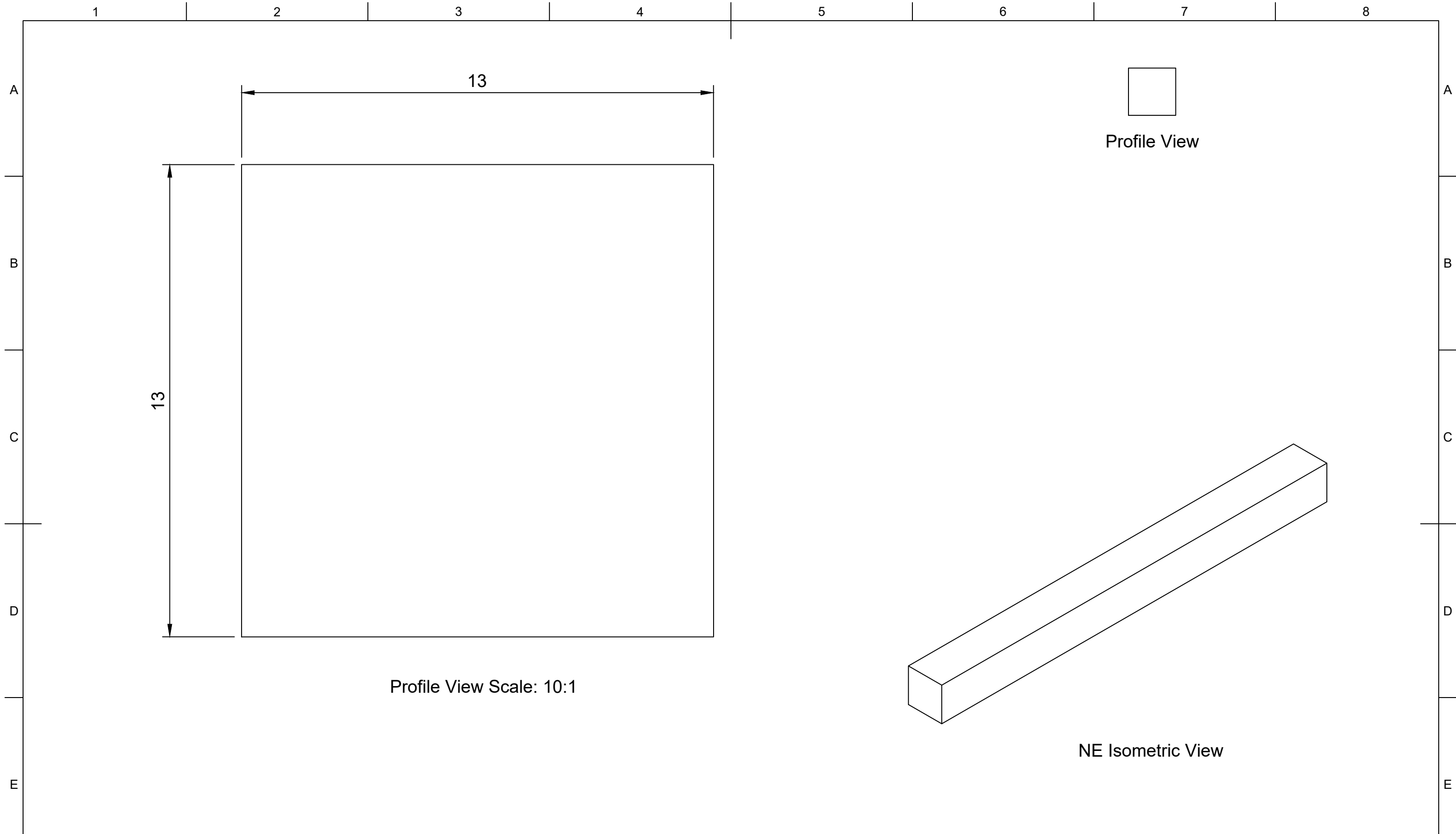

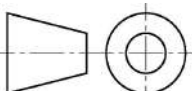
	Part Number				Created By		Cross Sectional Area (mm²)		Nominal Dimension (mm)		Tolerance, ± (mm)
	202600				Isaac Erskine		169		Greater Than	Less Than or Equal to	
	Description				Date Drawn		Material		0.00	1.50	0.40
	Square - Solid				29/08/2020		Nitrile		1.50	2.50	0.50
	Revision				Approved By		Hardness (Shore A)		2.50	4.00	0.70
	A	21/02/2022		10:1	A3	1/1	Isaac Erskine		4.00	6.30	0.80
	Date of Issue		Sheet Scale		Sheet Size		Date of Approval		6.30	10.00	1.00
	21/02/2022		10:1		A3		21/02/2022		10.00	16.00	1.30
	Projection		Weight (g/m)		3rd Agl. 		204		16.00	25.00	1.60
									25.00	40.00	2.00
								40.00	63.00	2.50	
								63.00	100.00	3.20	
								100.00		3.20%	

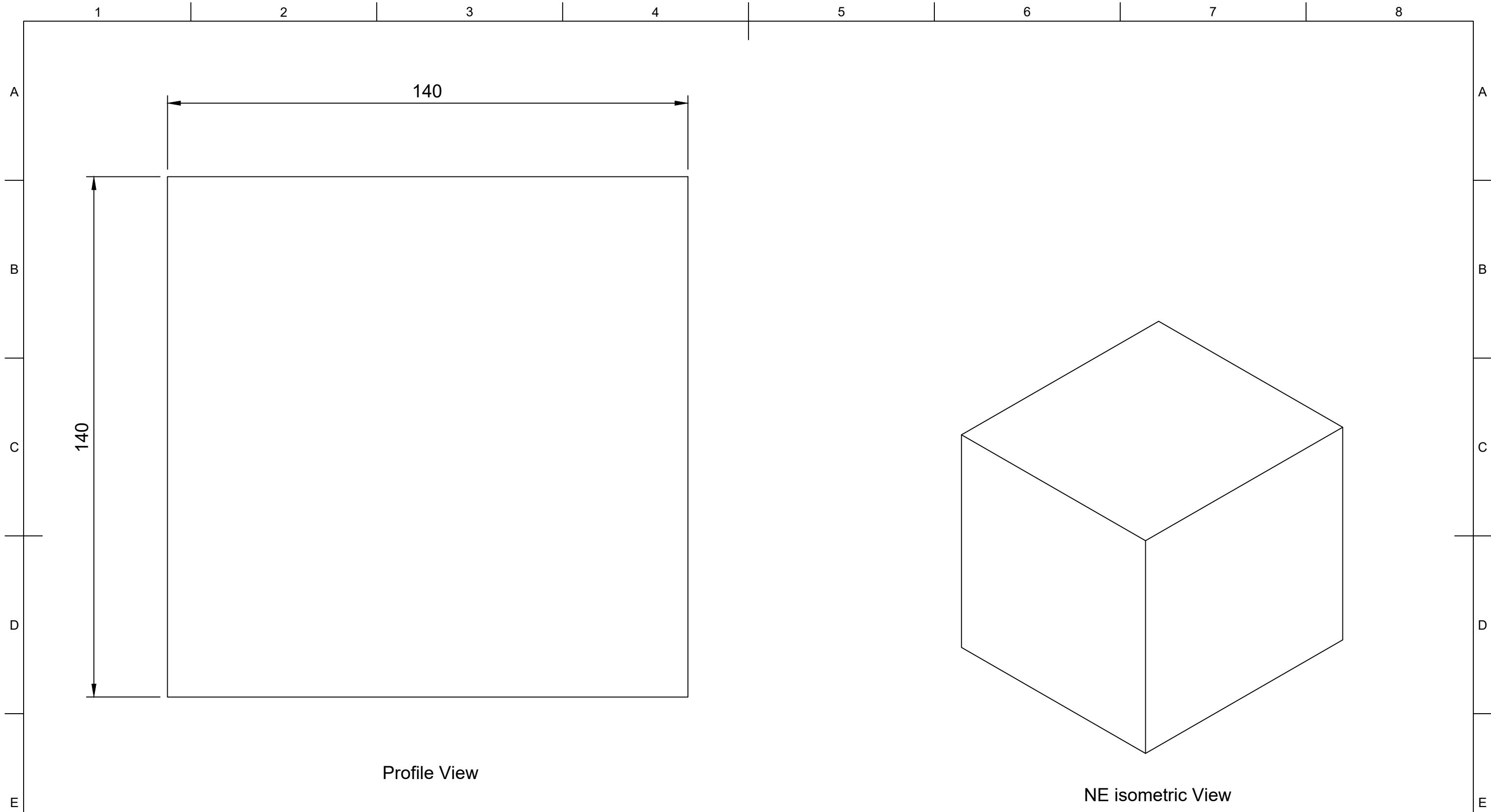

Profile View

NE isometric View

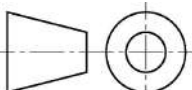
	Part Number				Created By		Cross Sectional Area (mm²)		Nominal Dimension (mm)		Tolerance, ± (mm)	
	200250				Isaac Erskine		19600		Greater Than	Less Than or Equal to		
	Description				Date Drawn		Material		0.00		0.40	
	Square - Solid				29/08/2020		EPDM		1.50		0.50	
	Revision				Approved By		Hardness (Shore A)		2.50		0.70	
	A	Date of Issue		Sheet Scale		Isaac Erskine		70		4.00		0.80
		21/02/2022		1:1		21/02/2022		Colour		6.30		1.00
				Sheet Size		Date of Approval		Black		10.00		1.30
				A3		21/02/2022		Weight (kg/m)		16.00		1.60
				1/1		Projection		24.696		25.00		2.00
					3rd Agl. 				40.00		2.50	
									63.00		3.20	
									100.00		3.20%	

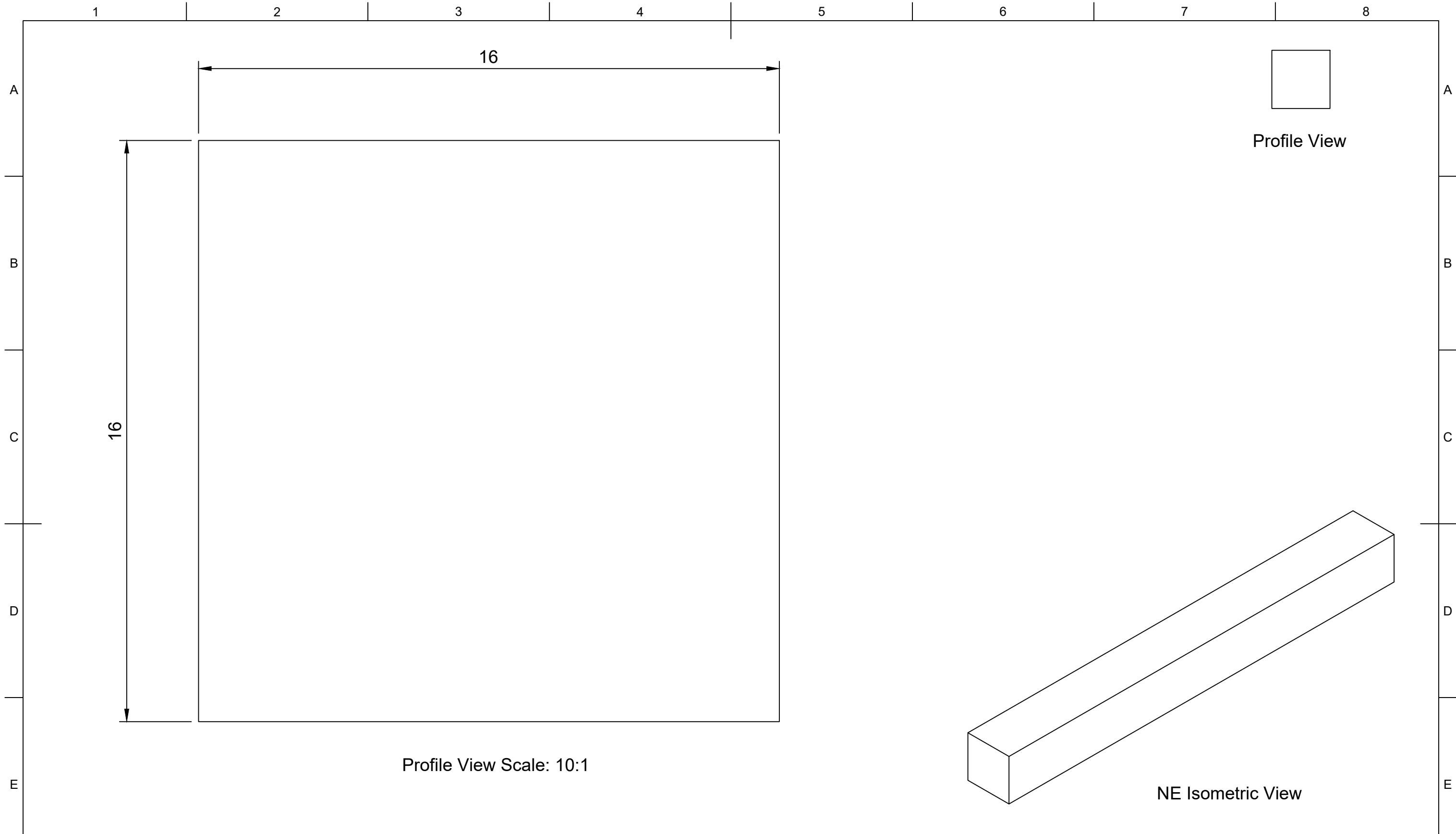

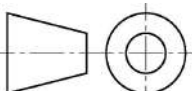
	Part Number				Created By		Cross Sectional Area (mm²)		Nominal Dimension (mm)		Tolerance, ± (mm)
	201213				Isaac Erskine		256		Greater Than	Less Than or Equal to	
	Description				Date Drawn		Material		0.00	1.50	0.40
	Square - Solid				29/08/2020		EPDM		1.50	2.50	0.50
	Revision				Approved By		Hardness (Shore A)		2.50	4.00	0.70
	A	21/02/2022		Isaac Erskine		70		4.00	6.30	0.80	
	Date of Issue		Sheet Scale		Date of Approval		Colour		6.30	10.00	1.00
	1:1		A3		21/02/2022		Black		10.00	16.00	1.30
	Sheet Size		Sheet		Projection		Weight (g/m)		16.00	25.00	1.60
	A3		1/1		3rd Ang. 		323		25.00	40.00	2.00
								40.00	63.00	2.50	
								63.00	100.00	3.20	
								100.00		3.20%	

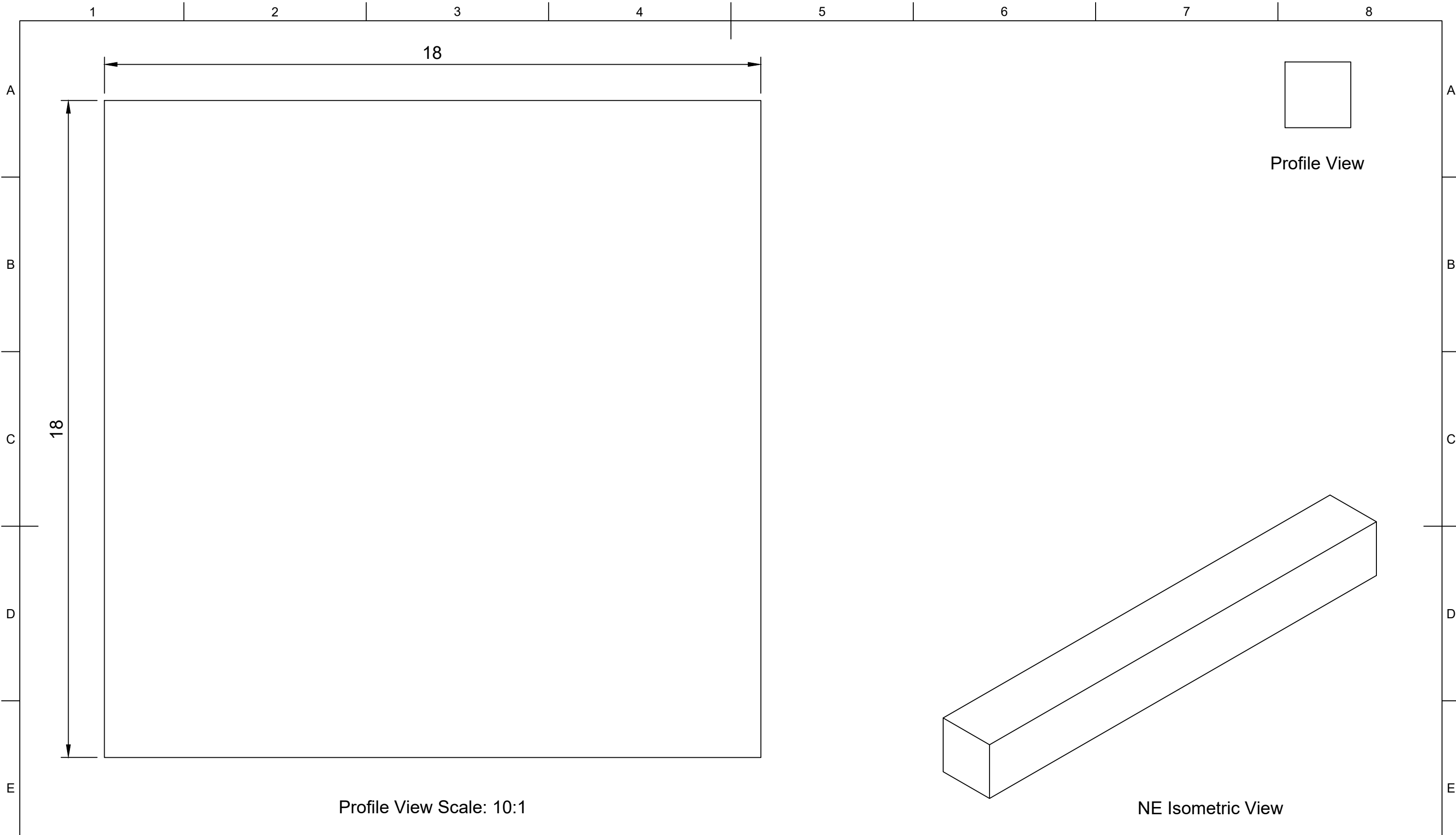

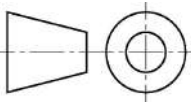
	Part Number				Created By		Cross Sectional Area (mm²)		Nominal Dimension (mm)		Tolerance, ± (mm)
	204409				Isaac Erskine		324		Greater Than	Less Than or Equal to	
	Description				Date Drawn		Material				
	Square - Solid				29/08/2020		Nitrile				
					Approved By		Hardness (Shore A)				
					Isaac Erskine		70				
					Date of Approval		Colour				
					21/02/2022		Black				
					Projection		Weight (g/m)				
					3rd Ang. 		392				
Revision	Date of Issue	Sheet Scale	Sheet Size	Sheet							
A	21/02/2022	1:1	A3	1/1							
								25.00	40.00	2.00	
								40.00	63.00	2.50	
								63.00	100.00	3.20	
								100.00		3.20%	

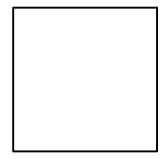
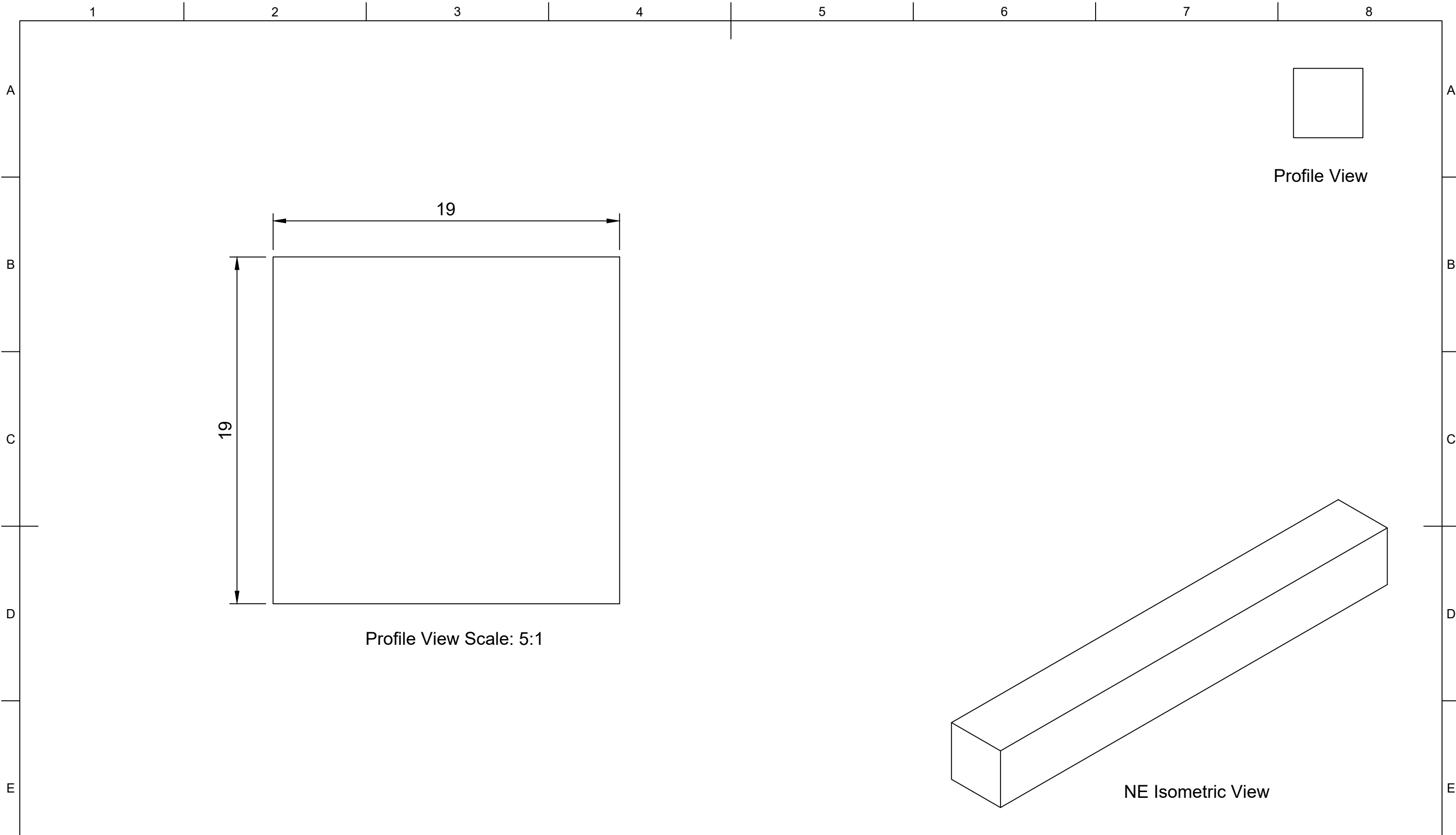

Profile View

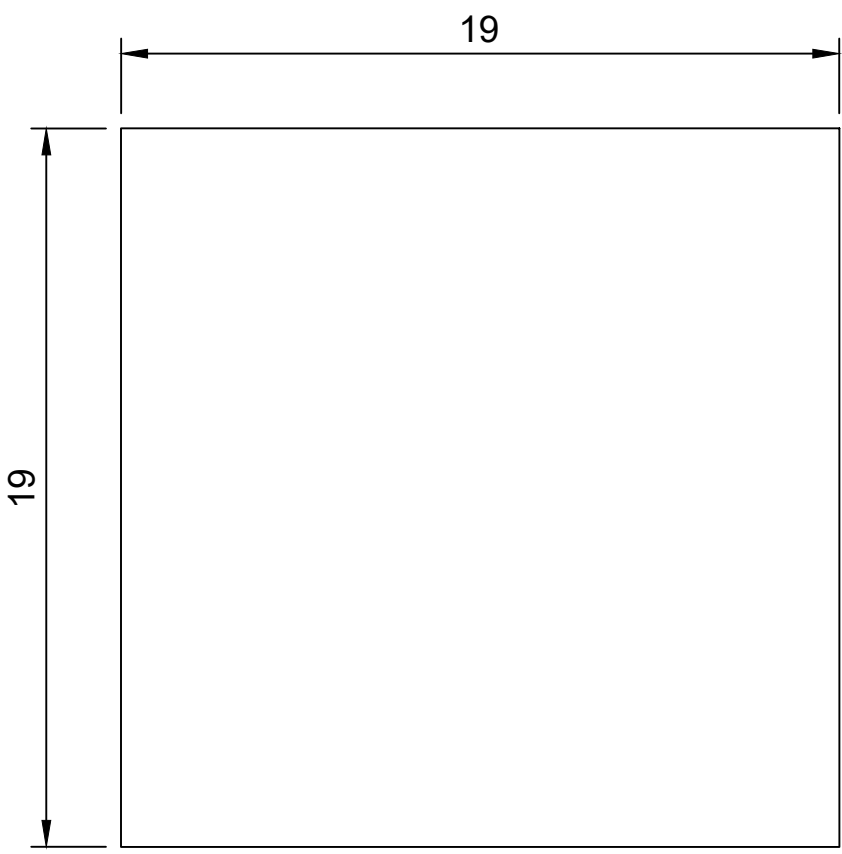

Profile View Scale: 5:1

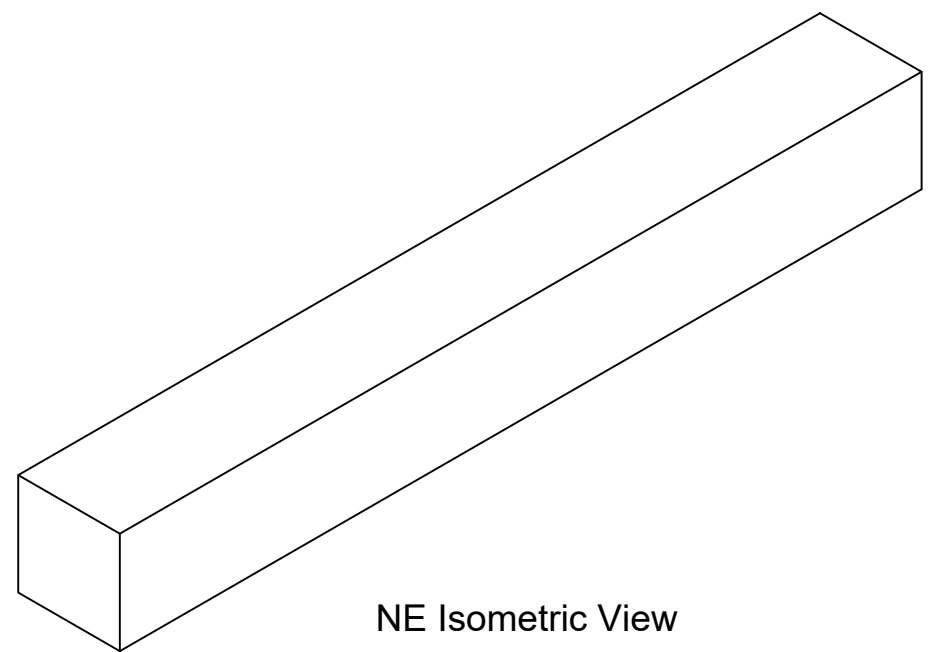

NE Isometric View

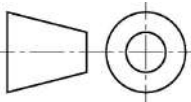
	Part Number				Created By		Cross Sectional Area (mm²)		Nominal Dimension (mm)		Tolerance, ± (mm)
	208650				Isaac Erskine		361		Greater Than	Less Than or Equal to	
	Description				Date Drawn		Material		0.00	1.50	0.40
					29/08/2020		EPDM		1.50	2.50	0.50
	Square - Solid				Approved By		Hardness (Shore A)		2.50	4.00	0.70
					Isaac Erskine		70		4.00	6.30	0.80
					Date of Approval		Colour		6.30	10.00	1.00
					21/02/2022		Black		10.00	16.00	1.30
	Revision				Projection		Weight (g/m)		16.00	25.00	1.60
	A	21/02/2022	1:1	A3	1/1	3rd Agl.	455		25.00	40.00	2.00
								40.00	63.00	2.50	
								63.00	100.00	3.20	
								100.00		3.20%	

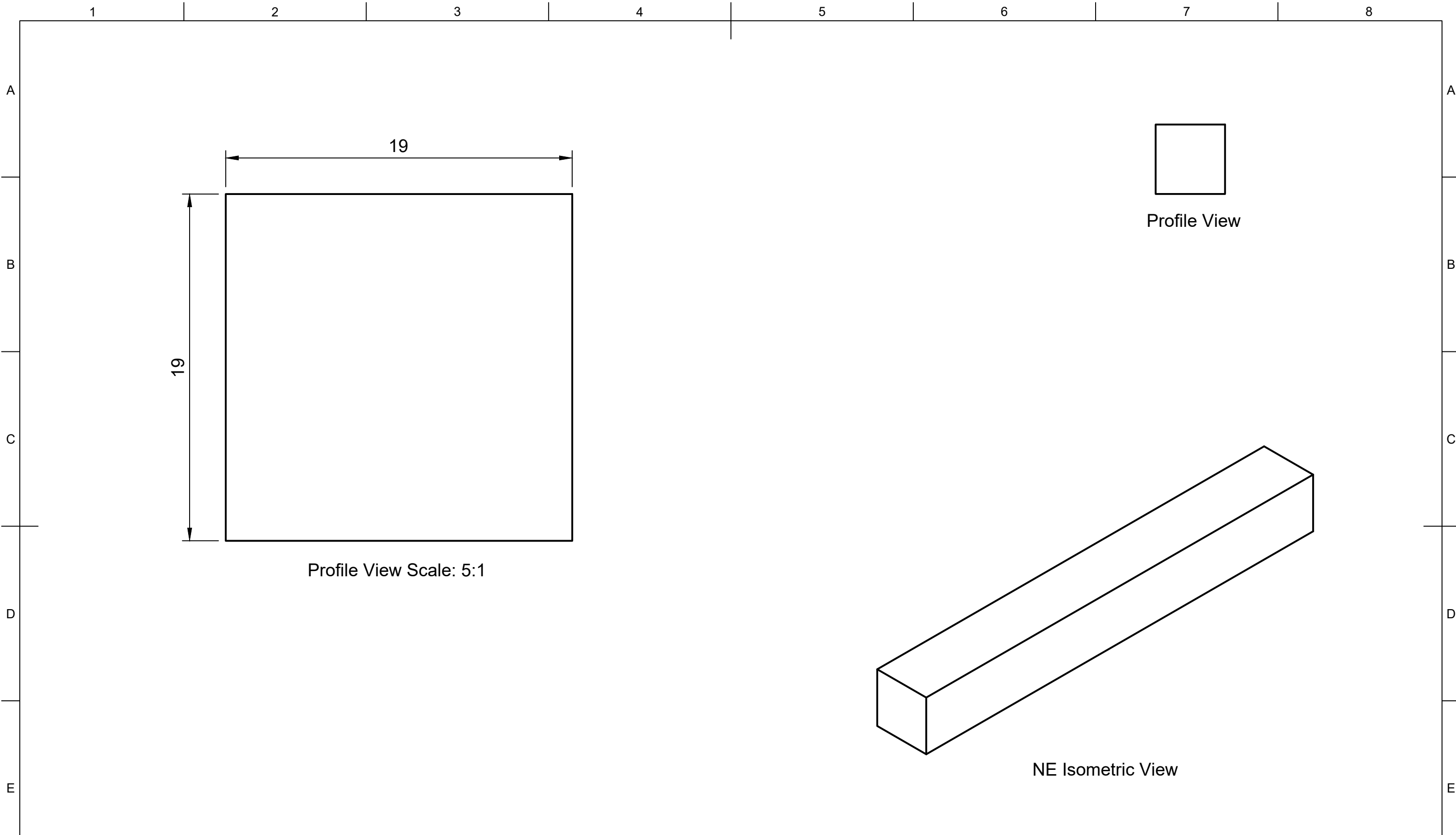

	Part Number				Created By		Cross Sectional Area (mm²)		Nominal Dimension (mm)		Tolerance, ± (mm)
	208222				Isaac Erskine		361		Greater Than	Less Than or Equal to	
	Description				Date Drawn		Material		0.00	1.50	0.40
	Square - Solid				21/02/2022		Nitrile		1.50	2.50	0.50
	Revision				Approved By		Hardness (Shore A)		2.50	4.00	0.70
	A	21/02/2022		Isaac Erskine		70		4.00	6.30	0.80	
	Date of Issue				Date of Approval		Colour		6.30	10.00	1.00
	1:1				21/02/2022		Black		10.00	16.00	1.30
	Sheet Scale				Projection		Weight (g/m)		16.00	25.00	1.60
	A3				3rd Agl.		437		25.00	40.00	2.00
Sheet Size								40.00	63.00	2.50	
1/1								63.00	100.00	3.20	
								100.00		3.20%	

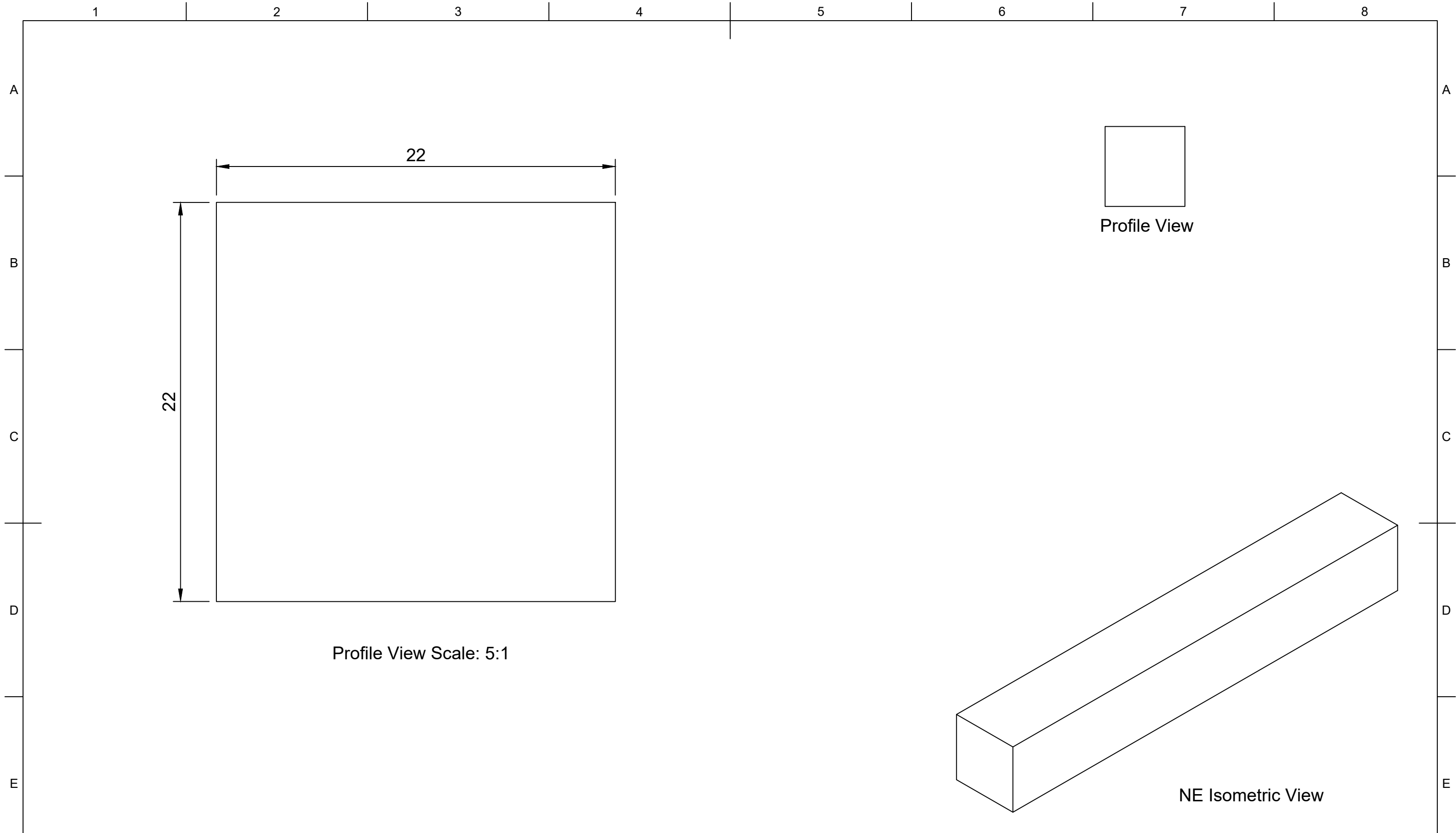

Profile View Scale: 5:1

NE Isometric View

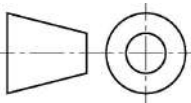
	Part Number				Created By		Cross Sectional Area (mm²)		Nominal Dimension (mm)		Tolerance, ± (mm)
	201012				Isaac Erskine		484		Greater Than	Less Than or Equal to	
	Description				Date Drawn		Material		0.00	1.50	0.40
	Square - Solid				29/08/2020		EPDM		1.50	2.50	0.50
	Revision				Approved By		Hardness (Shore A)		2.50	4.00	0.70
	A	Date of Issue		Sheet Scale	Sheet Size	Sheet	Isaac Erskine		4.00	6.30	0.80
		21/02/2022		1:1	A3	1/1	21/02/2022		6.30	10.00	1.00
	Projection				Date of Approval		Colour		10.00	16.00	1.30
	3rd Agl. 				21/02/2022		Black		16.00	25.00	1.60
	Weight (g/m)						610		25.00	40.00	2.00
								40.00	63.00	2.50	
								63.00	100.00	3.20	
								100.00		3.20%	

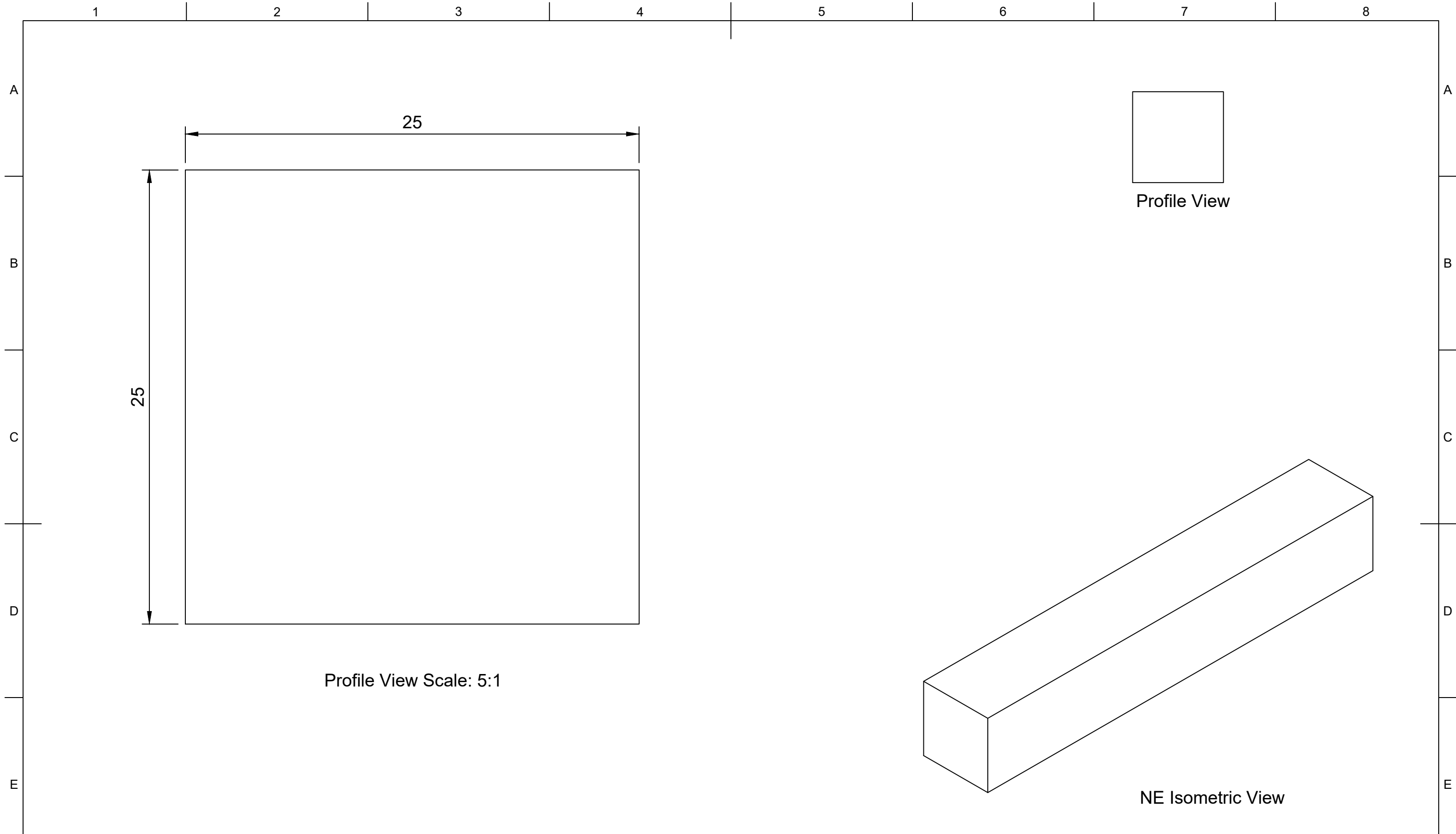

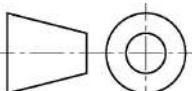
	Part Number				Created By		Cross Sectional Area (mm²)		Nominal Dimension (mm)		Tolerance, ± (mm)		
	209193				Isaac Erskine		625		Greater Than	Less Than or Equal to			
	Description				Date Drawn		Material		0.00	1.50	0.40		
	Square - Solid				29/08/2020		EPDM		1.50	2.50	0.50		
	Revision				Approved By		Hardness (Shore A)		2.50	4.00	0.70		
	A	21/02/2022		1:1	A3	1/1	Isaac Erskine		4.00	6.30	0.80		
	Date of Issue		Sheet Scale		Sheet Size		Date of Approval		Colour		6.30	10.00	1.00
	21/02/2022		1:1		A3		21/02/2022		Black		10.00	16.00	1.30
	Projection				3rd Agl.		Weight (g/m)		16.00	25.00	1.60		
	3rd Agl. 				788				25.00	40.00	2.00		
								40.00	63.00	2.50			
								63.00	100.00	3.20			
								100.00		3.20%			

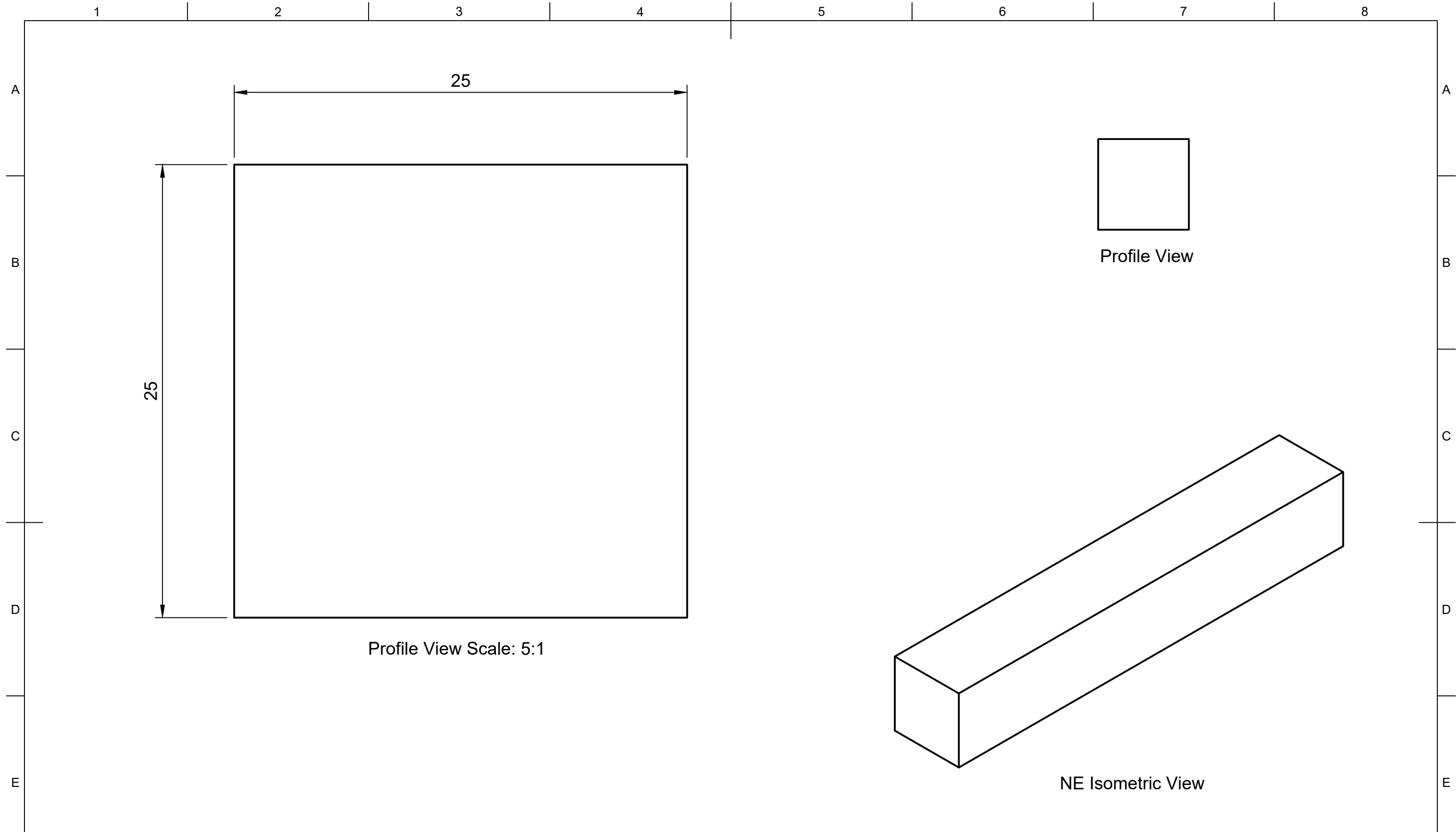

Part Number		204880			Created By	Isaac Erskine	Cross Sectional Area (mm ²)	625		Nominal Dimension (mm)		Tolerance, ± (mm)
					Date Drawn	21/02/2022	Material	Nitrile	Greater Than	Less Than or Equal to		
Description		Square - Solid			Approved By	Isaac Erskine	Hardness (Shore A)	70		0.00	1.50	0.40
					Date of Approval	21/02/2022	Colour	Black	1.50	2.50	0.50	
Revision	Date of Issue	Sheet Scale	Sheet Size	Sheet	Projection	3rd Agl.	Weight (g/m)	756		2.50	4.00	0.70
A	21/02/2022	1:1	A3	1/1				6.30	10.00	1.00		
										10.00	16.00	1.30
										16.00	25.00	1.60
										25.00	40.00	2.00
										40.00	63.00	2.50
										63.00	100.00	3.20
										100.00		3.20%

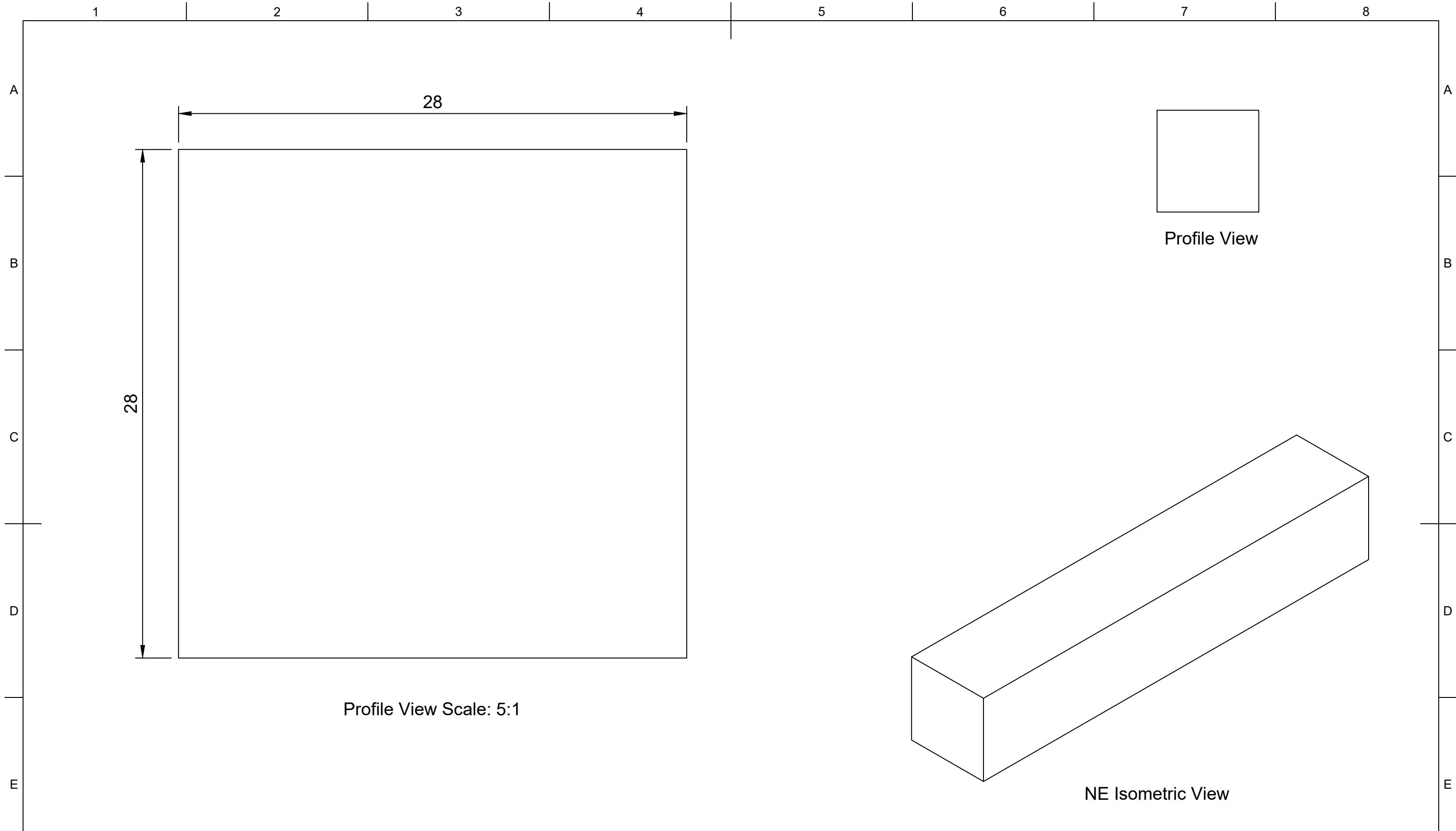

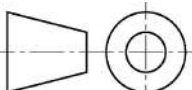
	Part Number				Created By		Cross Sectional Area (mm²)		Nominal Dimension (mm)		Tolerance, ± (mm)
	202127				Isaac Erskine		784		Greater Than	Less Than or Equal to	
	Description				Date Drawn		Material		0.00	1.50	0.40
	Square - Solid				29/08/2020		EPDM		1.50	2.50	0.50
	Revision				Approved By		Hardness (Shore A)		2.50	4.00	0.70
	A	Date of Issue			Isaac Erskine		70		4.00	6.30	0.80
		21/02/2022			21/02/2022		Colour		6.30	10.00	1.00
		Sheet Scale	Sheet Size	Sheet	Date of Approval		Black		10.00	16.00	1.30
		1:1	A3	1/1	21/02/2022		Weight (g/m)		16.00	25.00	1.60
					Projection		988		25.00	40.00	2.00
				3rd Agl. 				40.00	63.00	2.50	
								63.00	100.00	3.20	
								100.00		3.20%	

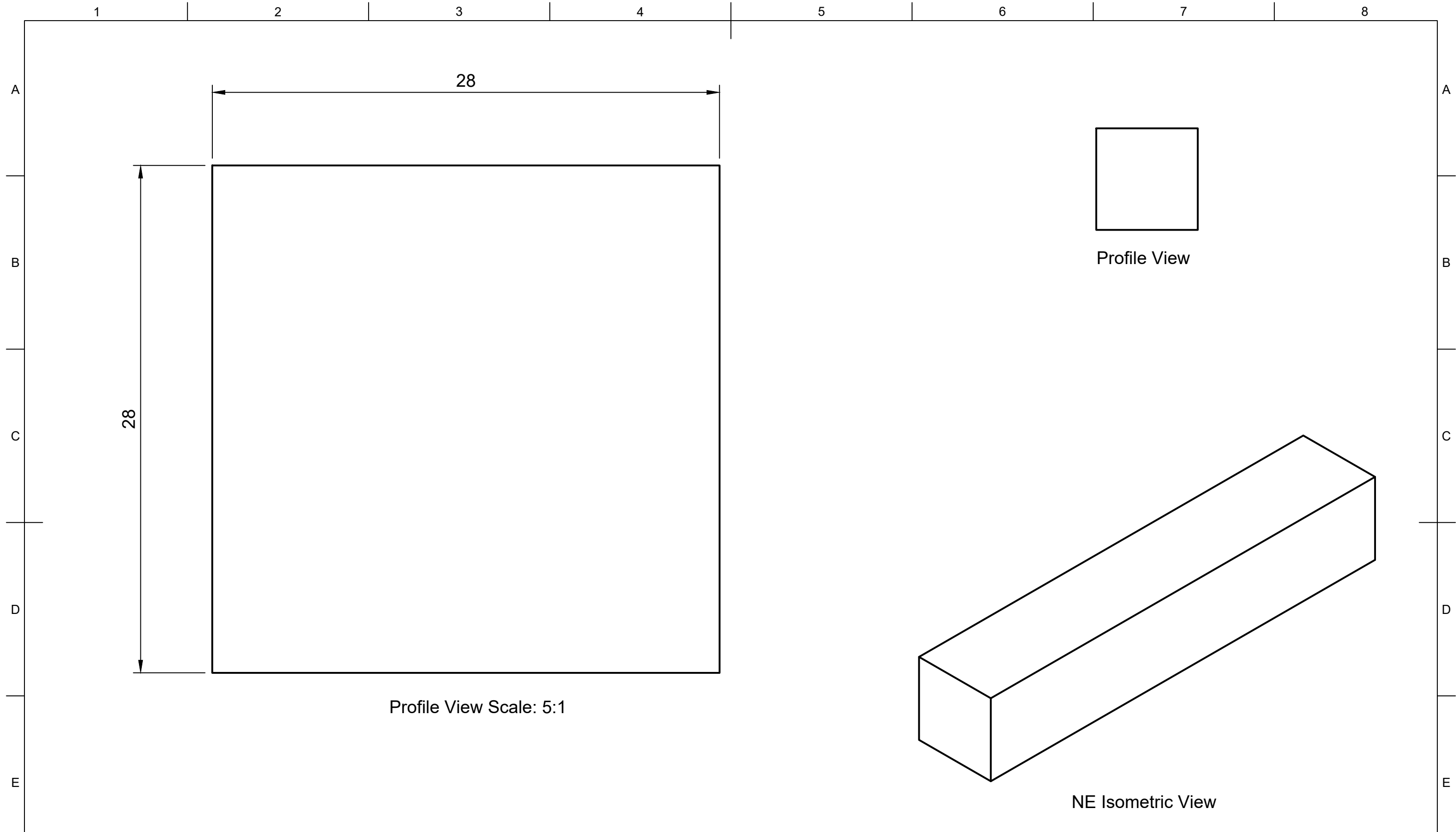

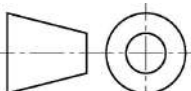
	Part Number				Created By		Cross Sectional Area (mm²)		Nominal Dimension (mm)		Tolerance, ± (mm)
	201507				Isaac Erskine		784		Greater Than	Less Than or Equal to	
	Description				Date Drawn		Material		0.00	1.50	0.40
					21/02/2022		Neoprene		1.50	2.50	0.50
	Square - Solid				Approved By		Hardness (Shore A)		2.50	4.00	0.70
					Isaac Erskine		70		4.00	6.30	0.80
					Date of Approval		Colour		6.30	10.00	1.00
					21/02/2022		Black		10.00	16.00	1.30
	Revision				Projection		Weight (kg/m)		16.00	25.00	1.60
	A	21/02/2022	1:1	A3	1/1	3rd Agl. 	1.192		25.00	40.00	2.00
								40.00	63.00	2.50	
								63.00	100.00	3.20	
								100.00		3.20%	

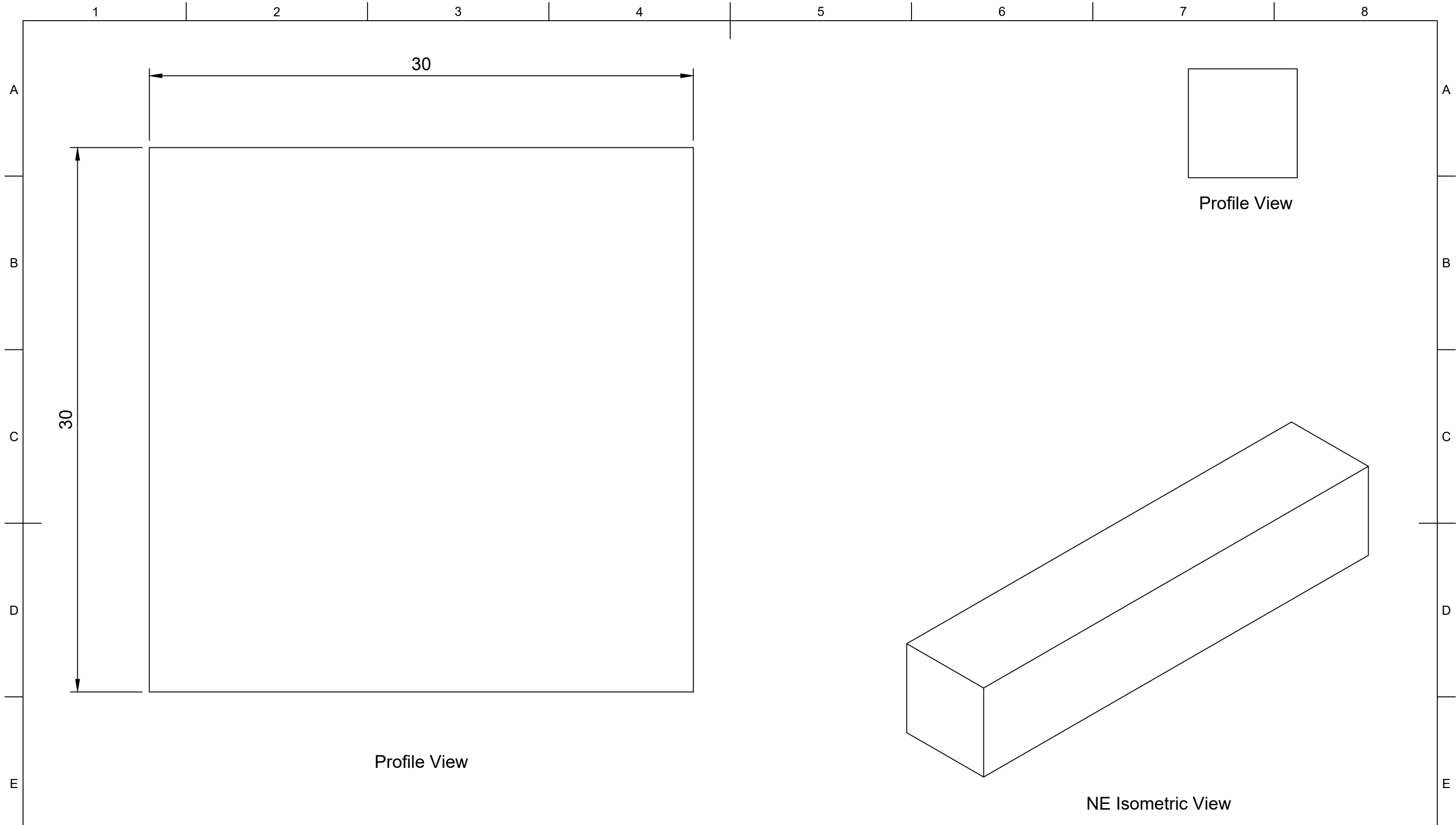

WALKERRUBBER LTD	Part Number				Created By		Cross Sectional Area (mm²)		Nominal Dimension (mm)		Tolerance, ± (mm)
	202171				Isaac Erskine		900		Greater Than	Less Than or Equal to	
	Description				Date Drawn		Material		0.00	1.50	0.40
	Square - Solid				30/08/2020		EPDM		1.50	2.50	0.50
	Revision				Approved By		Hardness (Shore A)		2.50	4.00	0.70
	A	Date of Issue			Isaac Erskine		70		4.00	6.30	0.80
		21/02/2022			Date of Approval		Black		6.30	10.00	1.00
		1:1			21/02/2022		Weight (kg/m)		10.00	16.00	1.30
		A3			Projection		1.134		16.00	25.00	1.60
		1/1			3rd Agl.				25.00	40.00	2.00
								40.00	63.00	2.50	
								63.00	100.00	3.20	
								100.00		3.20%	

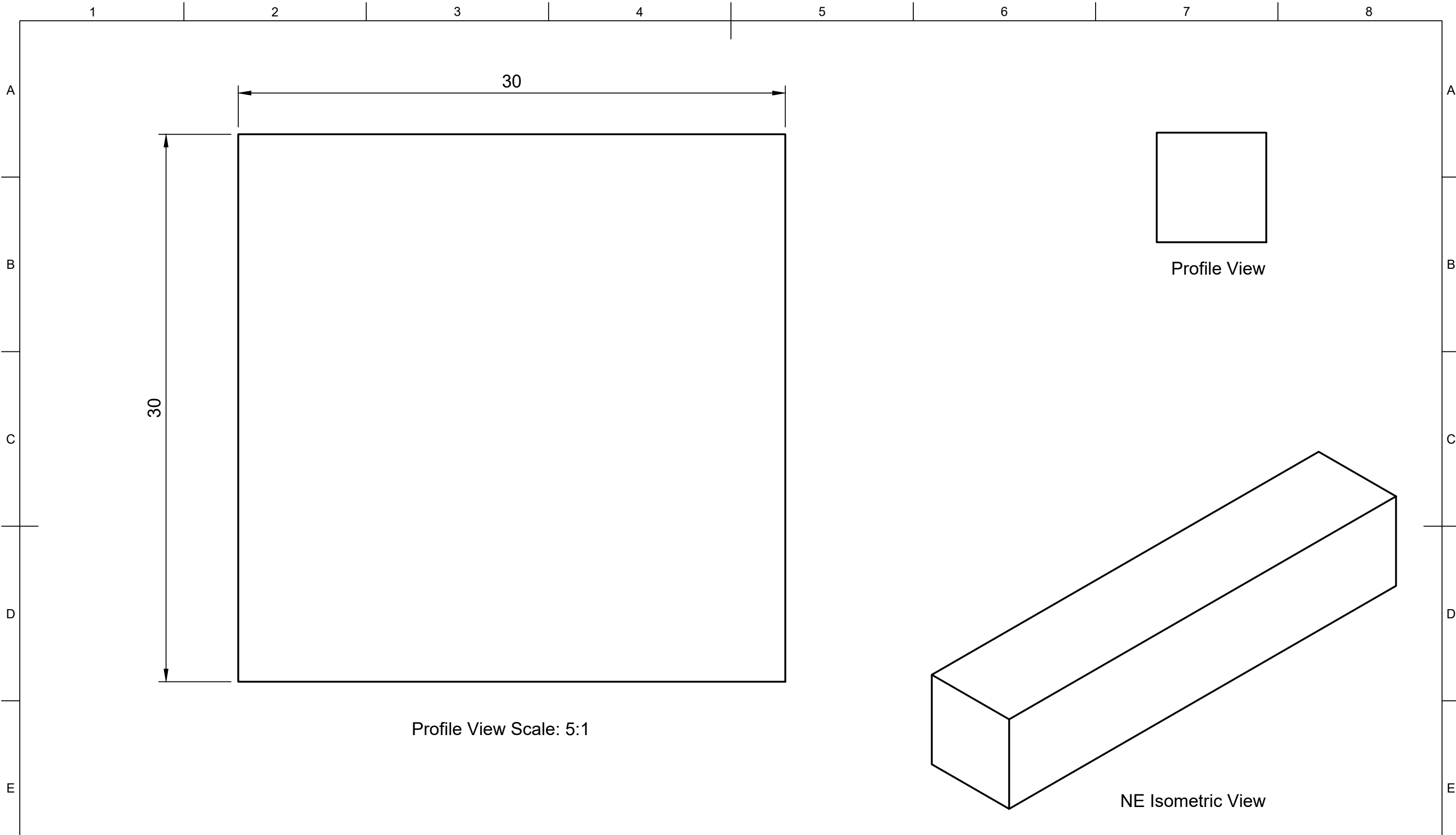

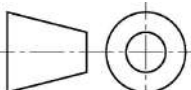
	Part Number				Created By		Cross Sectional Area (mm²)		Nominal Dimension (mm)		Tolerance, ± (mm)
	203298				Isaac Erskine		900		Greater Than	Less Than or Equal to	
	Description				Date Drawn		Material		0.00		0.40
	Square - Solid				21/02/2022		Neoprene		1.50		0.50
	Revision				Approved By		Hardness (Shore A)		2.50		0.70
	A	21/02/2022		Isaac Erskine		70		4.00		0.80	
	Date of Issue				Date of Approval		Colour		6.30		1.00
	1:1				21/02/2022		Black		10.00		1.30
	Sheet Scale				Projection		Weight (kg/m)		16.00		1.60
	A3				3rd Agl. 		1.368		25.00		2.00
Sheet Size								40.00		2.50	
A3								63.00		3.20	
Sheet								100.00		3.20%	
1/1											

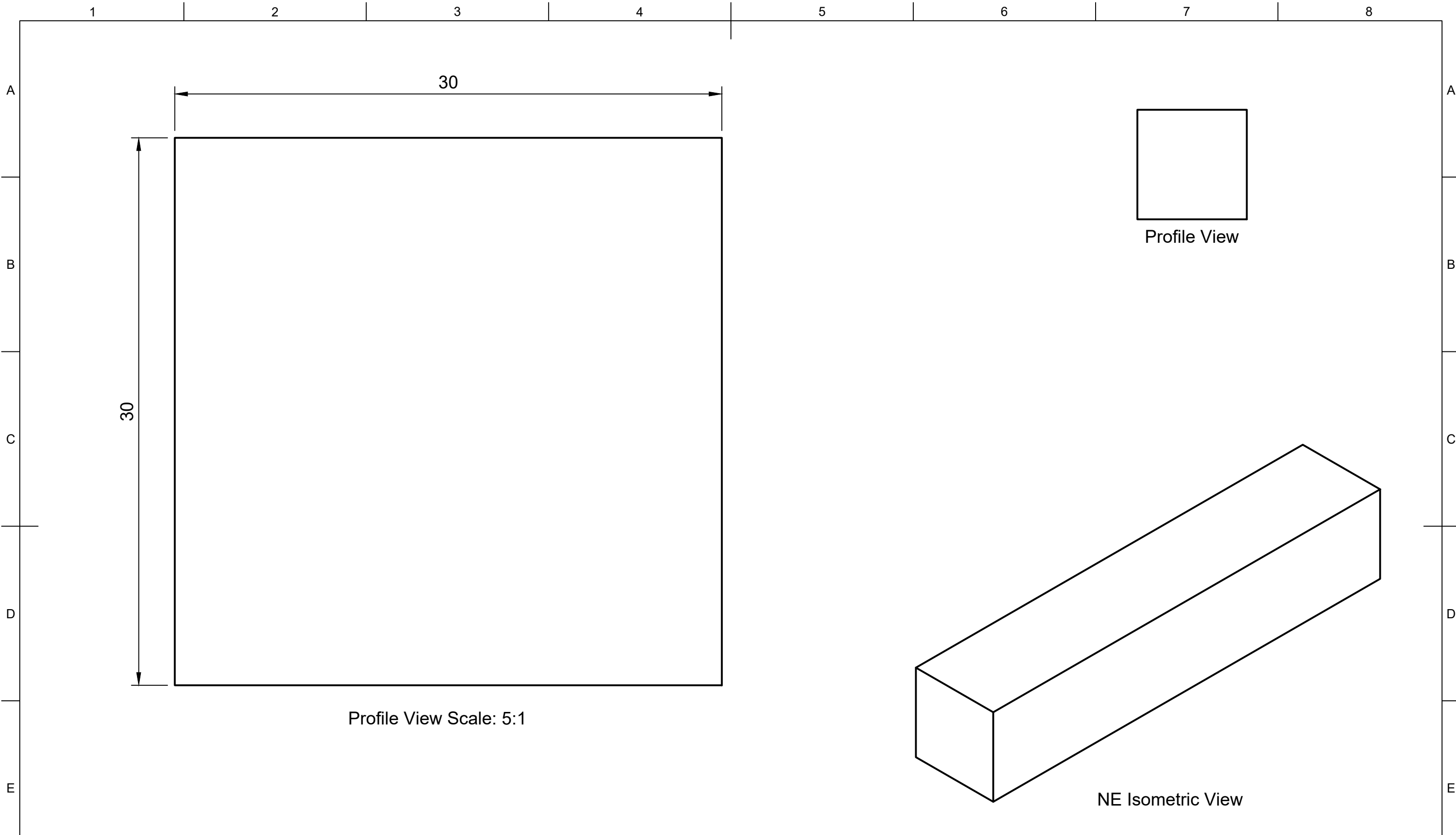

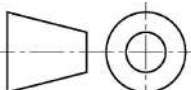
	Part Number				Created By		Cross Sectional Area (mm²)		Nominal Dimension (mm)		Tolerance, ± (mm)	
	201711				Isaac Erskine		900		Greater Than	Less Than or Equal to		
	Description				Date Drawn		Material		0.00		0.40	
	Square - Solid				21/02/2022		Nitrile		1.50		0.50	
	Revision				Approved By		Hardness (Shore A)		2.50		0.70	
	A	Date of Issue		Sheet Scale		Isaac Erskine		70		4.00		0.80
		21/02/2022		1:1		21/02/2022		Black		6.30		1.00
				Sheet Size		Date of Approval		Colour		10.00		1.30
				A3		21/02/2022		Weight (kg/m)		16.00		1.60
				1/1		3rd Agl. 		1.089		25.00		2.00
									40.00		2.50	
									63.00		3.20	
									100.00		3.20%	

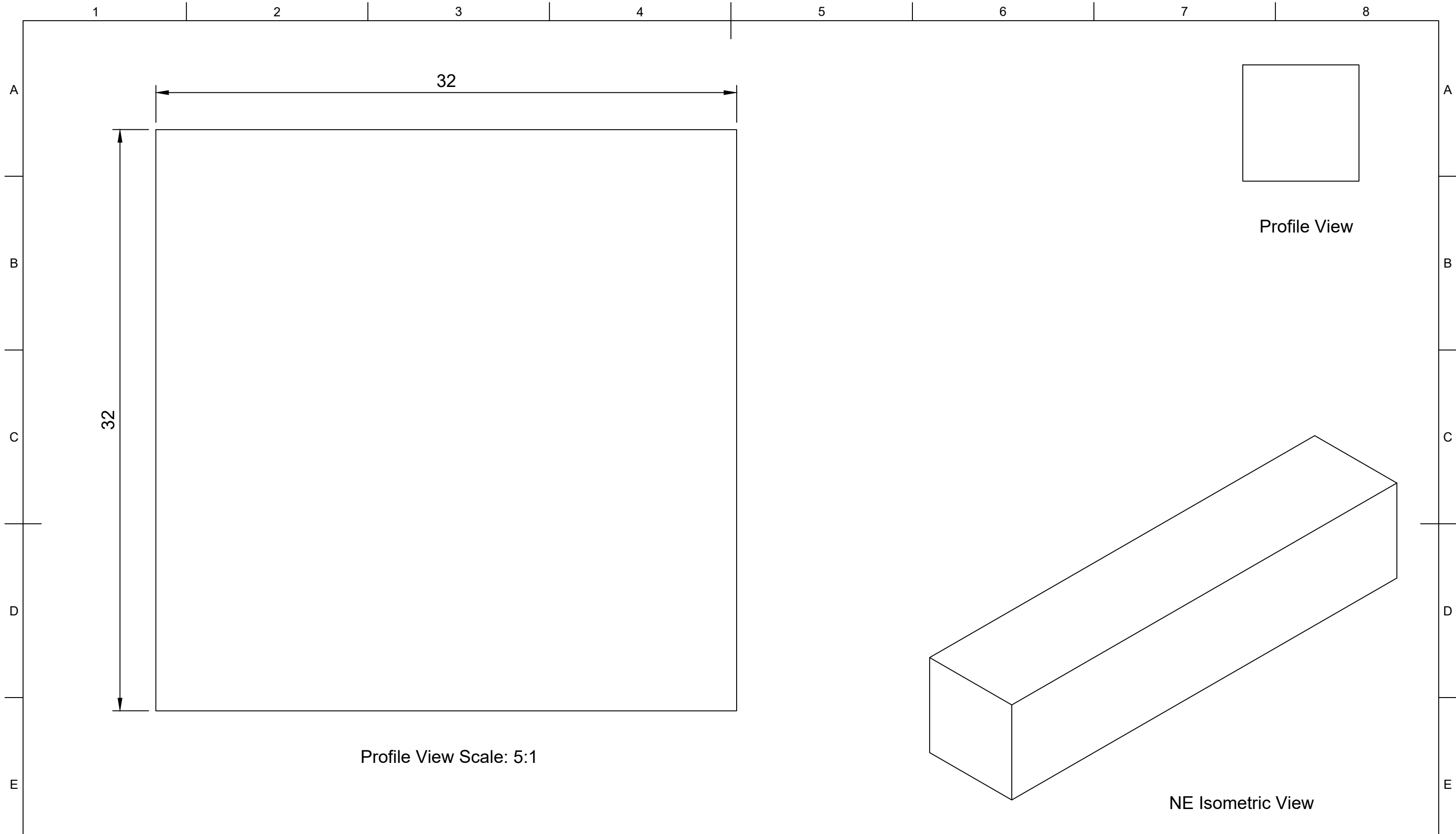

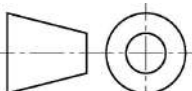
	Part Number				Created By		Cross Sectional Area (mm²)		Nominal Dimension (mm)		Tolerance, ± (mm)
	205841				Isaac Erskine		1024		Greater Than	Less Than or Equal to	
	Description				Date Drawn		Material		0.00	1.50	0.40
	Square - Solid				30/08/2020		EPDM		1.50	2.50	0.50
	Revision				Approved By		Hardness (Shore A)		2.50	4.00	0.70
	A	Date of Issue		Sheet Scale	Sheet Size	Sheet	Isaac Erskine		4.00	6.30	0.80
		21/02/2022		1:1	A3	1/1	21/02/2022		6.30	10.00	1.00
							Date of Approval		10.00	16.00	1.30
							21/02/2022		16.00	25.00	1.60
							Projection		25.00	40.00	2.00
						3rd Ang. 		40.00	63.00	2.50	
						Weight (kg/m)		63.00	100.00	3.20	
						1.290		100.00		3.20%	

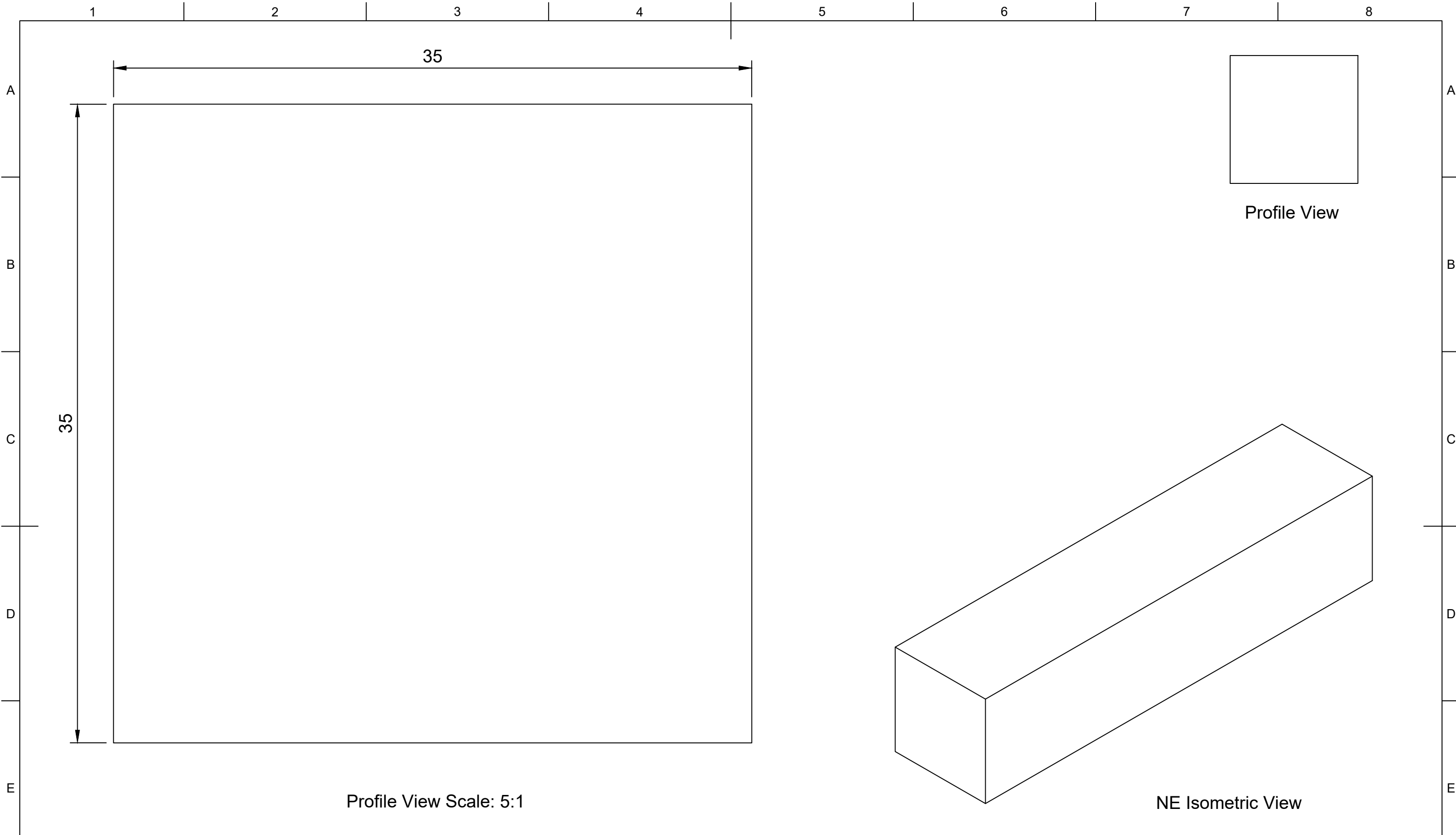

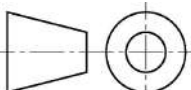
	Part Number				Created By		Cross Sectional Area (mm²)		Nominal Dimension (mm)		Tolerance, ± (mm)
	203912				Isaac Erskine		1225		Greater Than	Less Than or Equal to	
	Description				Date Drawn		Material				
	Square - Solid				30/08/2020		EPDM				
					Approved By		Hardness (Shore A)				
					Isaac Erskine		70				
					Date of Approval		Colour				
					24/02/2022		Black				
					Projection		Weight (kg/m)				
					3rd Angl. 		1.544				
Revision	Date of Issue	Sheet Scale	Sheet Size	Sheet							
A	24/02/2022	1:1	A3	1/1							
								25.00	40.00	2.00	
								40.00	63.00	2.50	
								63.00	100.00	3.20	
								100.00		3.20%	

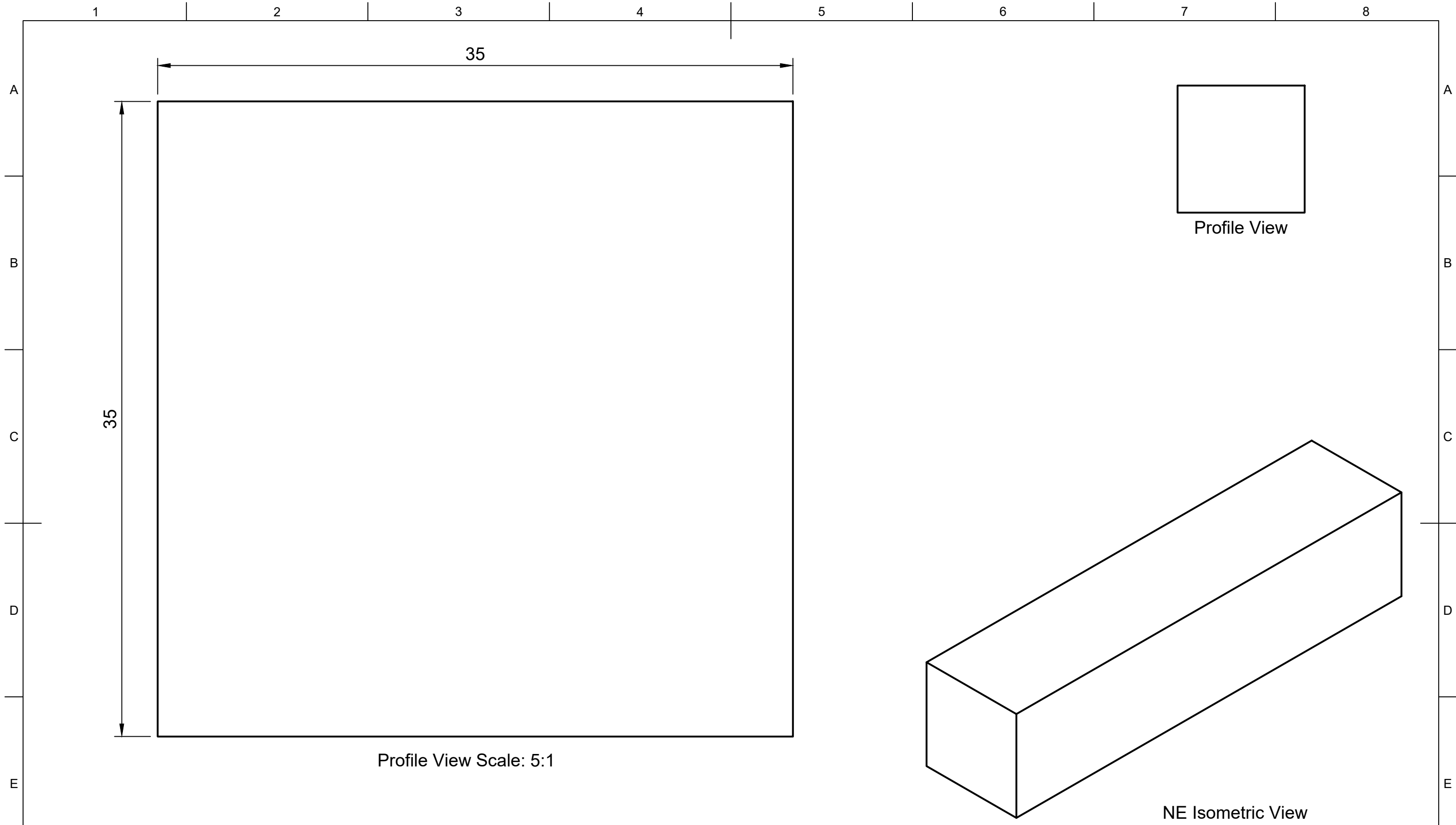

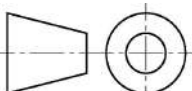
	Part Number				Created By		Cross Sectional Area (mm²)		Nominal Dimension (mm)		Tolerance, ± (mm)	
	208190				Isaac Erskine		1225		Greater Than	Less Than or Equal to		
	Description				Date Drawn		Material		0.00		0.40	
	Square - Solid				24/02/2022		Neoprene		1.50		0.50	
	Revision				Approved By		Hardness (Shore A)		2.50		0.70	
	A	Date of Issue		Sheet Scale		Isaac Erskine		Colour		4.00		0.80
		24/02/2022		1:1		24/02/2022		Black		6.30		1.00
				Sheet Size		Date of Approval		Weight (kg/m)		10.00		1.30
				A3		24/02/2022		1.862		16.00		1.60
				Sheet		Projection				25.00		2.00
			1/1		3rd Ang. 				40.00		2.50	
									63.00		3.20	
									100.00		3.20%	

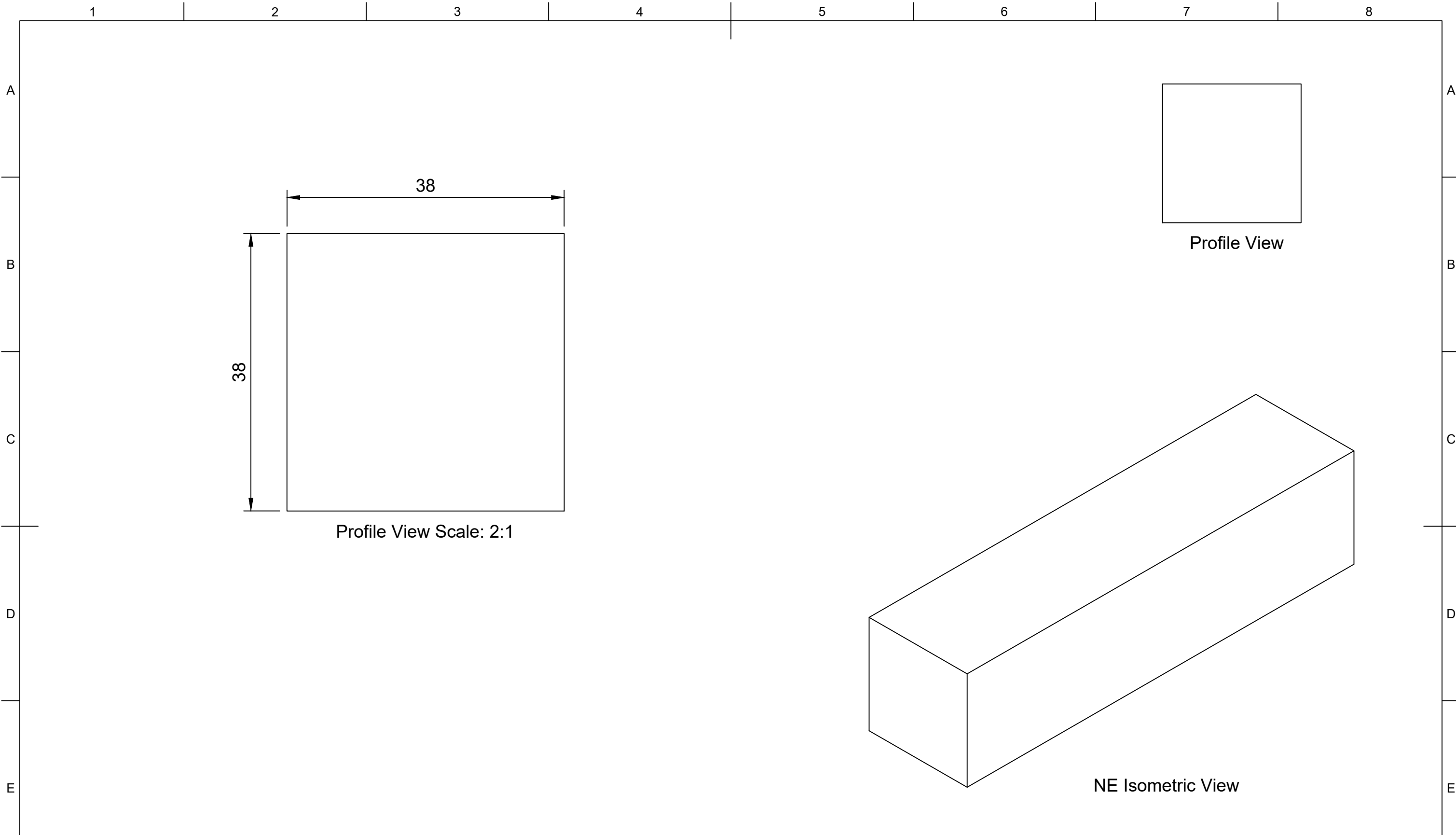

	Part Number				Created By		Cross Sectional Area (mm²)		Nominal Dimension (mm)		Tolerance, ± (mm)	
	SQ3838				Isaac Erskine		1444		Greater Than	Less Than or Equal to		
	Description				Date Drawn		Material					
	Square - Solid				30/08/2020		EPDM				0.40	
	Revision				Approved By		Hardness (Shore A)				1.50	
	A	Date of Issue		Sheet Scale		Isaac Erskine		70				2.50
		24/02/2022		2:1		24/02/2022		Black				4.00
				Sheet Size		Date of Approval		Colour				6.30
				A3		24/02/2022						10.00
				Sheet		Projection		Weight (kg/m)				16.00
			1/1		3rd Agl.		1.819				25.00	
											40.00	
											63.00	
											100.00	
											3.20%	

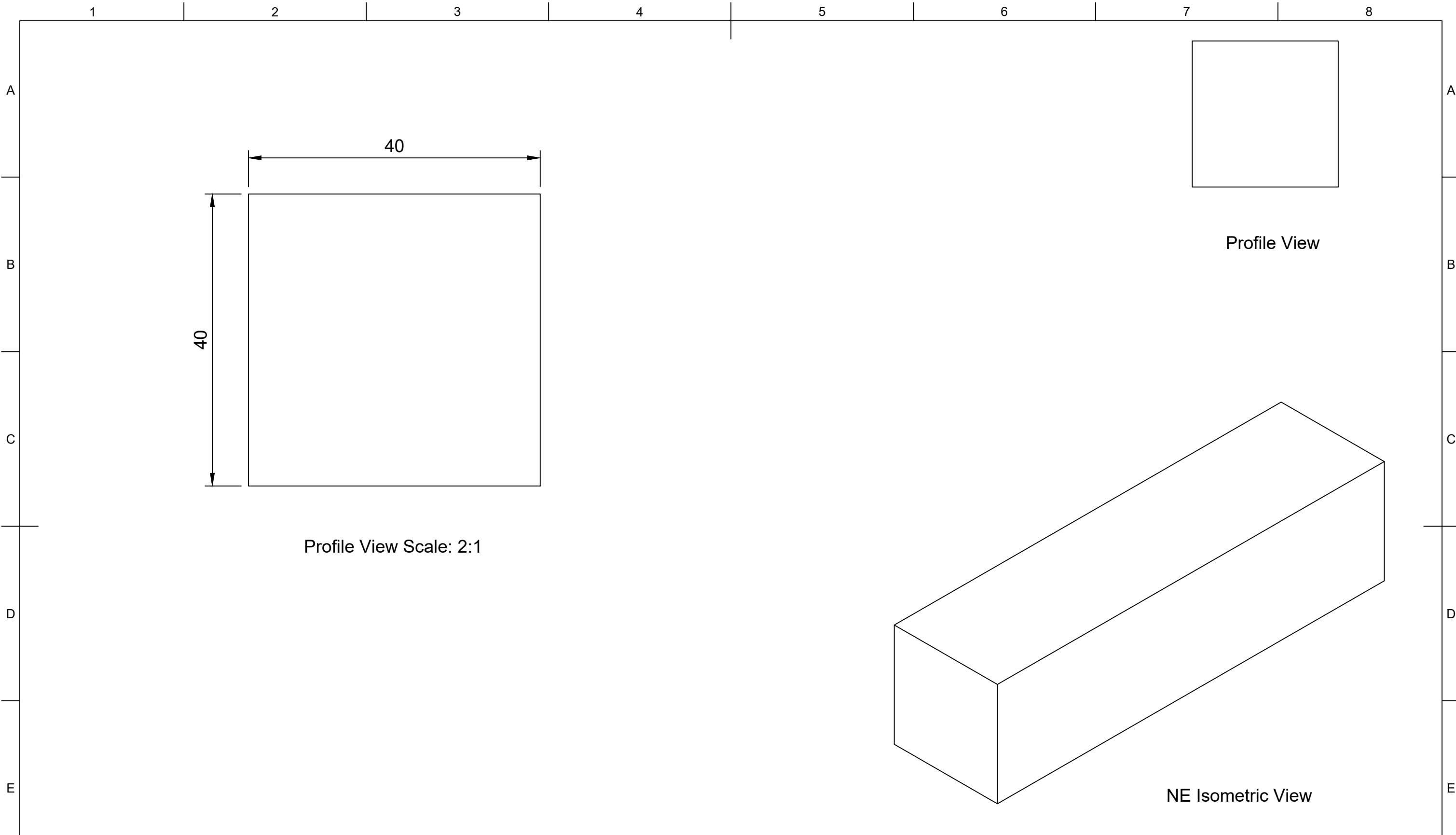

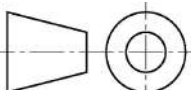
	Part Number				Created By		Cross Sectional Area (mm²)		Nominal Dimension (mm)		Tolerance, ± (mm)
	205200				Isaac Erskine		1600		Greater Than	Less Than or Equal to	
	Description				Date Drawn		Material		0.00	1.50	0.40
	Square - Solid				30/08/2020		EPDM		1.50	2.50	0.50
	Revision				Approved By		Hardness (Shore A)		2.50	4.00	0.70
	A	Date of Issue		Sheet Scale	Sheet Size	Sheet	Isaac Erskine		4.00	6.30	0.80
		24/02/2022		1:1	A3	1/1	24/02/2022		6.30	10.00	1.00
							Date of Approval		10.00	16.00	1.30
							24/02/2022		16.00	25.00	1.60
							Projection		25.00	40.00	2.00
						3rd Ang. 		40.00	63.00	2.50	
						Weight (kg/m)		63.00	100.00	3.20	
						2.016		100.00		3.20%	

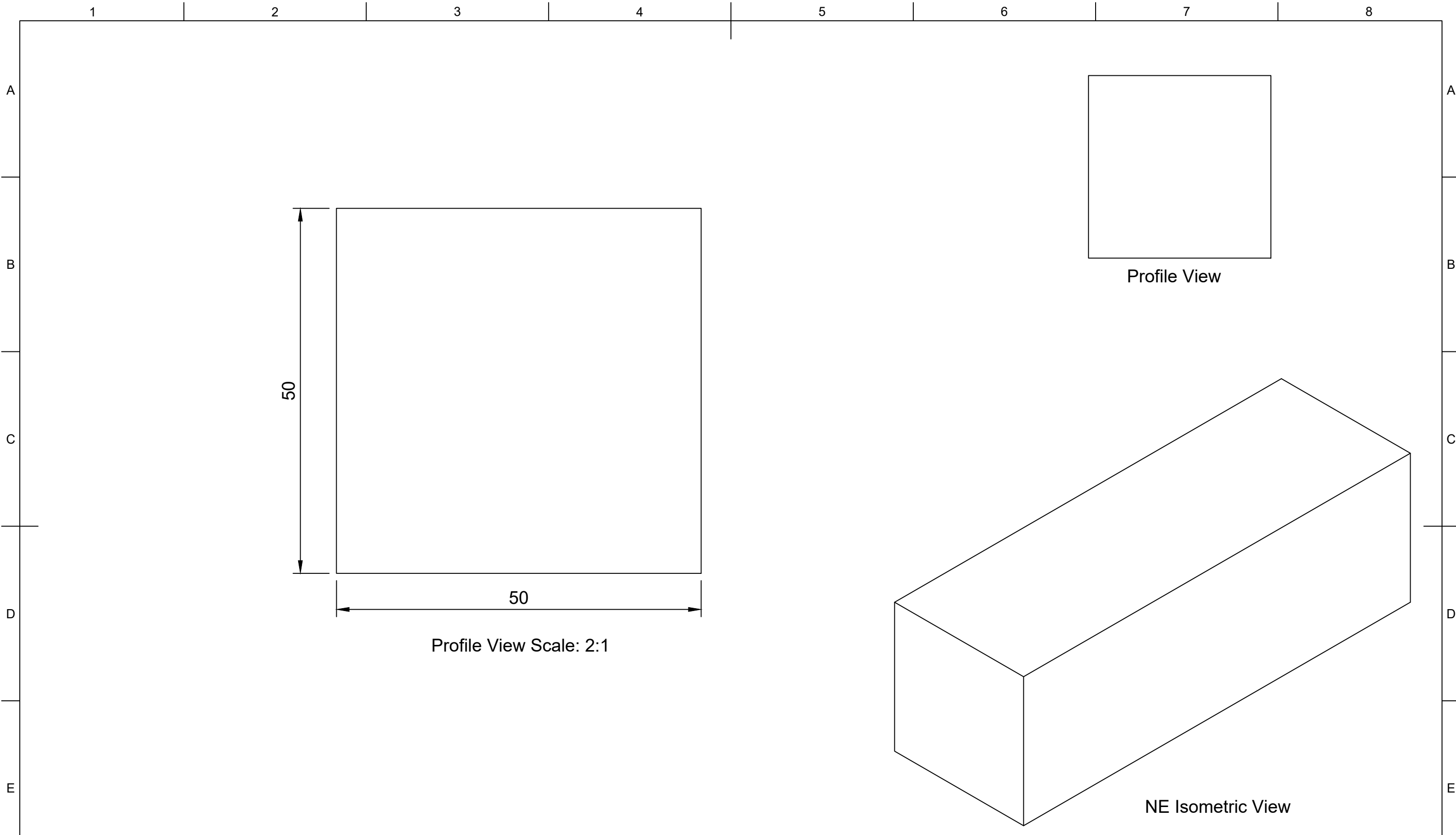

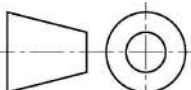
	Part Number				Created By		Cross Sectional Area (mm²)		Nominal Dimension (mm)		Tolerance, ± (mm)
	203056				Isaac Erskine		2500		Greater Than	Less Than or Equal to	
	Description				Date Drawn		Material		0.00	1.50	0.40
	Square - Solid				10/06/2020		EPDM		1.50	2.50	0.50
	Revision				Approved By		Hardness (Shore A)		2.50	4.00	0.70
	A	24/02/2022		Isaac Erskine		70		4.00	6.30	0.80	
	Date of Issue		Sheet Scale		Date of Approval		Colour		6.30	10.00	1.00
	1:1		A3		24/02/2022		Black		10.00	16.00	1.30
	Sheet Size		Sheet		Projection		Weight (kg/m)		16.00	25.00	1.60
	A3		1/1		3rd Agl. 		3.150		25.00	40.00	2.00
								40.00	63.00	2.50	
								63.00	100.00	3.20	
								100.00		3.20%	

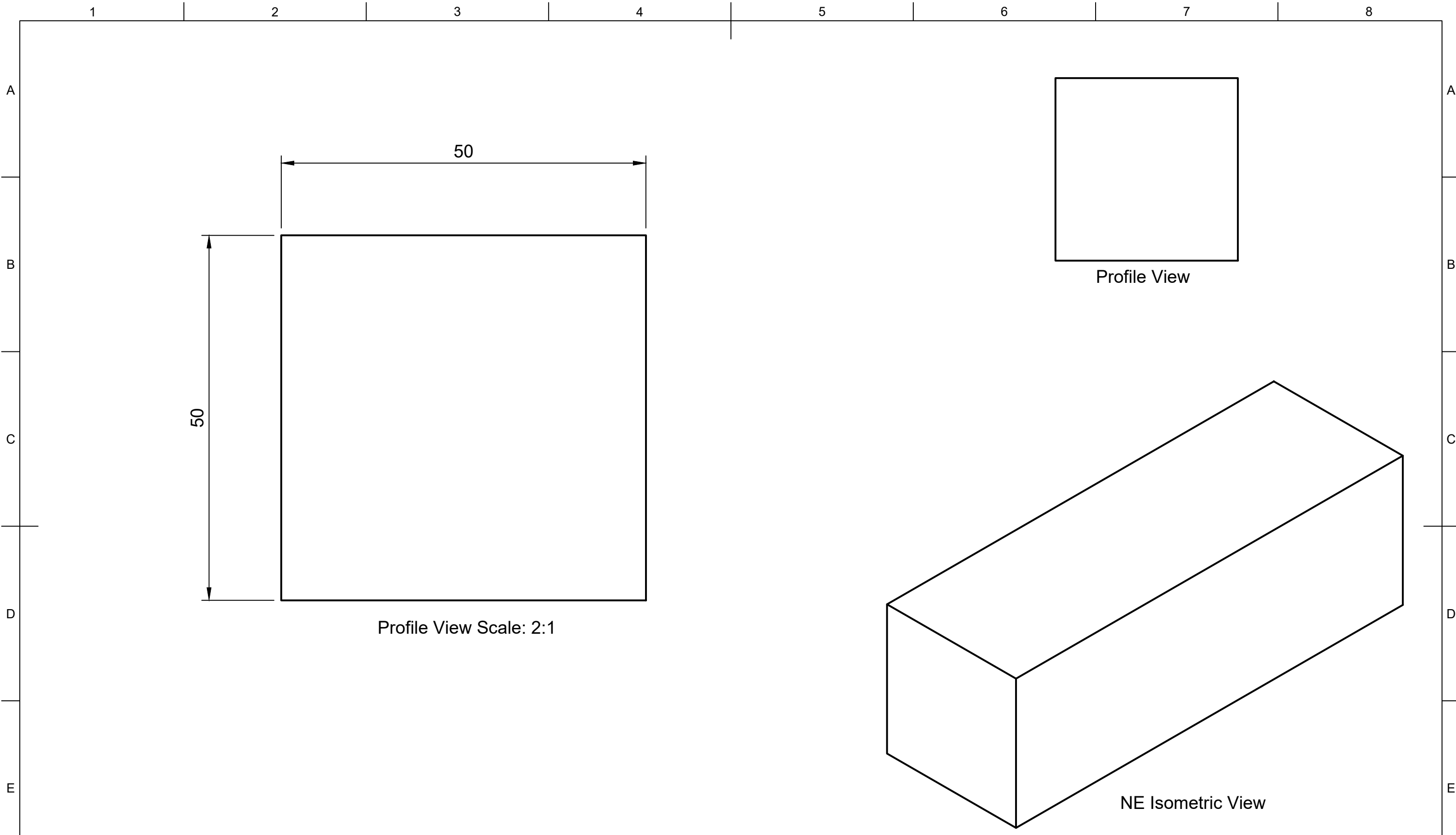

	Part Number				Created By		Cross Sectional Area (mm²)		Nominal Dimension (mm)		Tolerance, ± (mm)
	208090				Isaac Erskine		2500		Greater Than	Less Than or Equal to	
	Description				Date Drawn		Material		0.00	1.50	0.40
	Square - Solid				24/02/2022		Neoprene		1.50	2.50	0.50
	Revision				Approved By		Hardness (Shore A)		2.50	4.00	0.70
	A	24/02/2022		Isaac Erskine		70		4.00	6.30	0.80	
	Date of Issue				Date of Approval		Colour		6.30	10.00	1.00
	1:1				24/02/2022		Black		10.00	16.00	1.30
	Sheet Scale				Projection		Weight (kg/m)		16.00	25.00	1.60
	A3				3rd Agl.		3.800		25.00	40.00	2.00
Sheet Size								40.00	63.00	2.50	
A3								63.00	100.00	3.20	
Sheet								100.00		3.20%	
1/1											

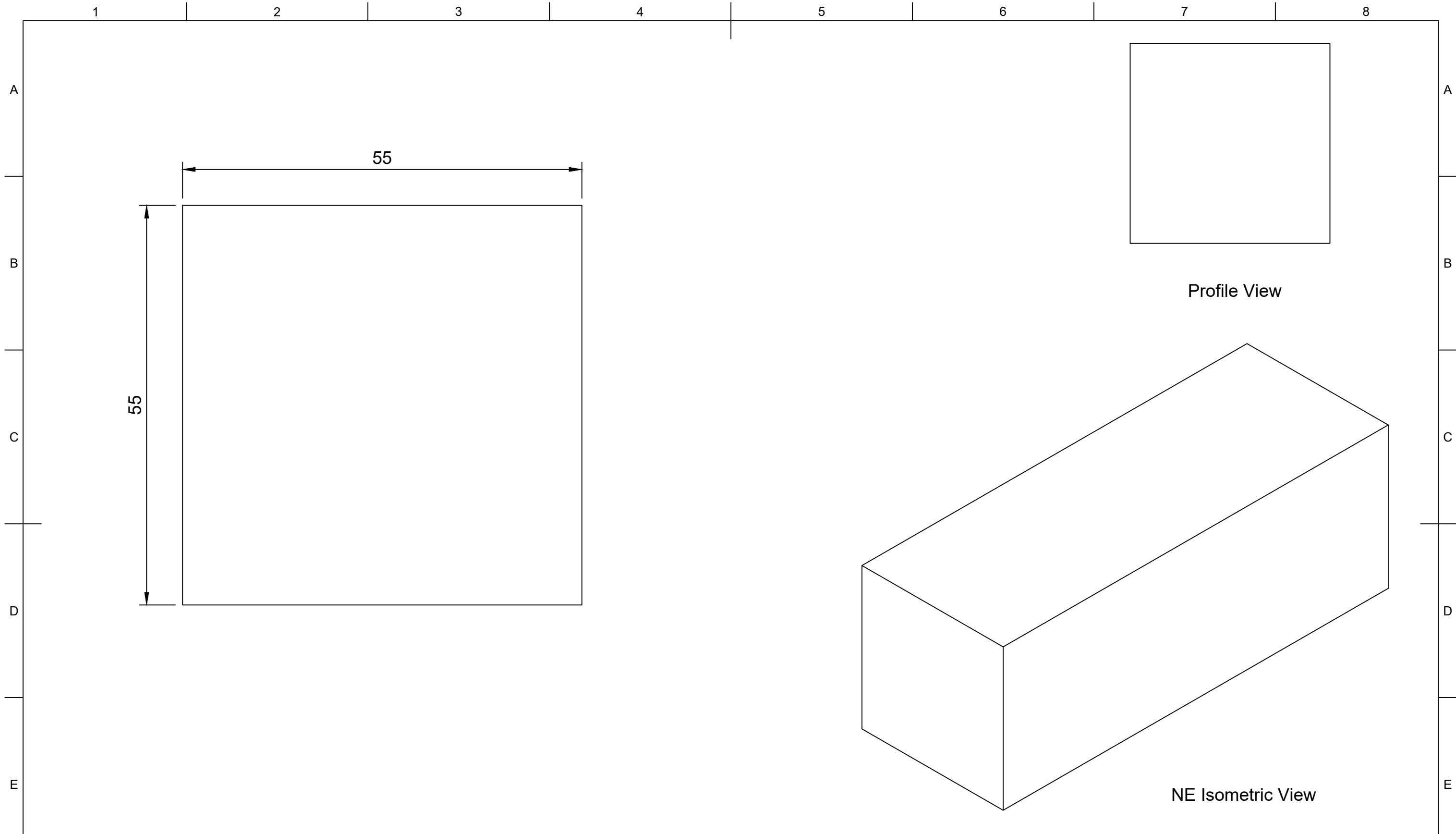

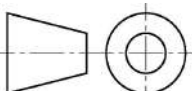
	Part Number				Created By		Cross Sectional Area (mm²)		Nominal Dimension (mm)		Tolerance, ± (mm)
	208039				Isaac Erskine		3025		Greater Than	Less Than or Equal to	
	Description				Date Drawn		Material		0.00	1.50	0.40
	Square - Solid				31/08/2020		EPDM		1.50	2.50	0.50
	Revision				Approved By		Hardness (Shore A)		2.50	4.00	0.70
	A	Date of Issue		Sheet Scale	Sheet Size	Sheet	Isaac Erskine		4.00	6.30	0.80
		28/02/22		1:1	A3	1/1	28/02/22		6.30	10.00	1.00
							Date of Approval		10.00	16.00	1.30
							28/02/22		16.00	25.00	1.60
							Projection		25.00	40.00	2.00
						3rd Agl. 		40.00	63.00	2.50	
						Weight (kg/m)		63.00	100.00	3.20	
						3.812		100.00		3.20%	

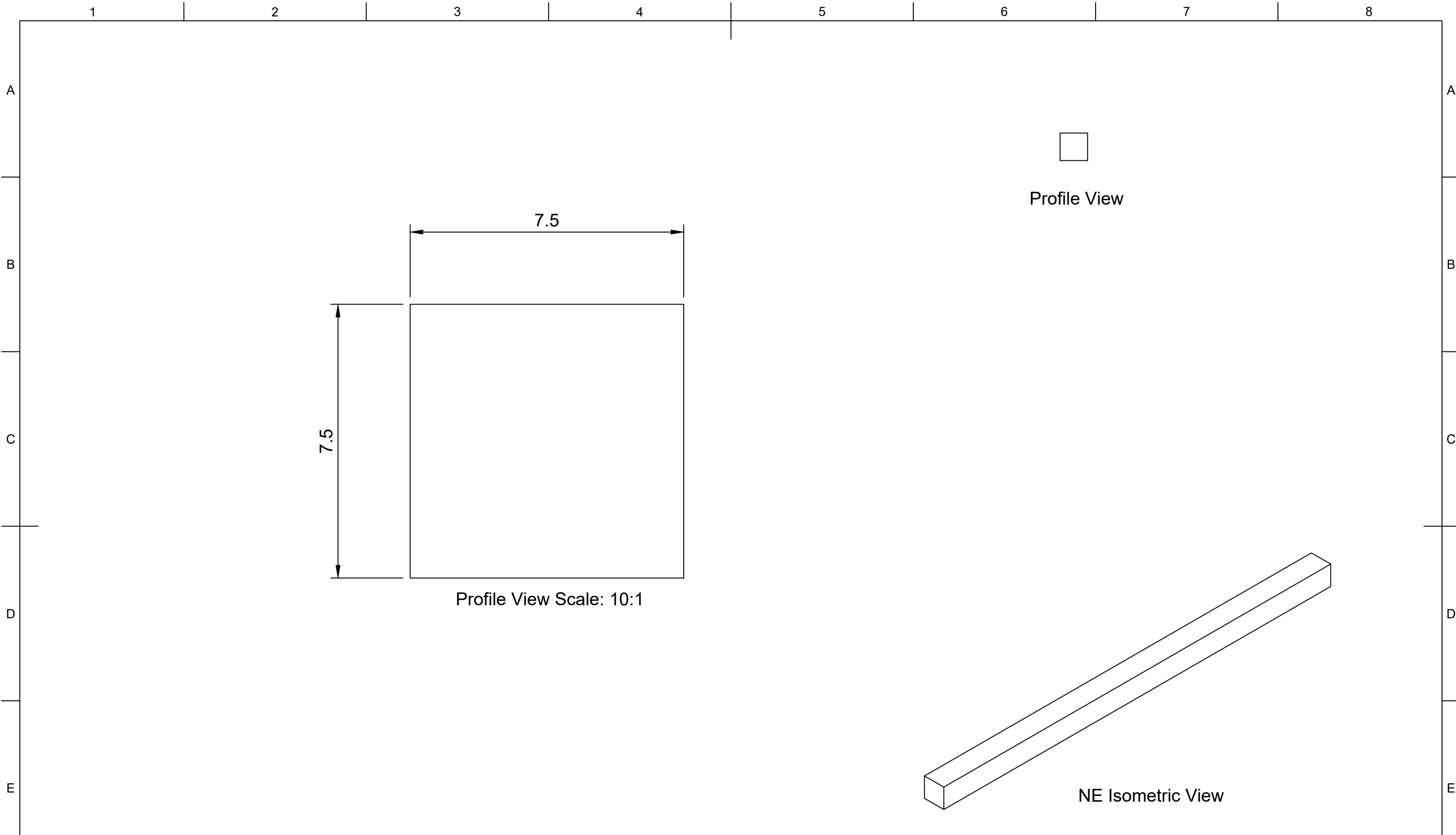

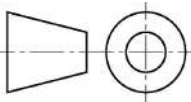
	Part Number				Created By		Cross Sectional Area (mm²)		Nominal Dimension (mm)		Tolerance, ± (mm)
	201343				Isaac Erskine		56		Greater Than	Less Than or Equal to	
	Description				Date Drawn		Material				
	Square - Solid				31/08/2020		EPDM				
					Approved By		Hardness (Shore A)				
					Isaac Erskine		70				
					Date of Approval		Colour				
					28/02/22		Black				
					Projection		Weight (g/m)				
					3rd Agl. 		71				
Revision	Date of Issue	Sheet Scale	Sheet Size	Sheet							
A	28/02/22	1:1	A3	1/1							
								25.00	40.00	2.00	
								40.00	63.00	2.50	
								63.00	100.00	3.20	
								100.00		3.20%	

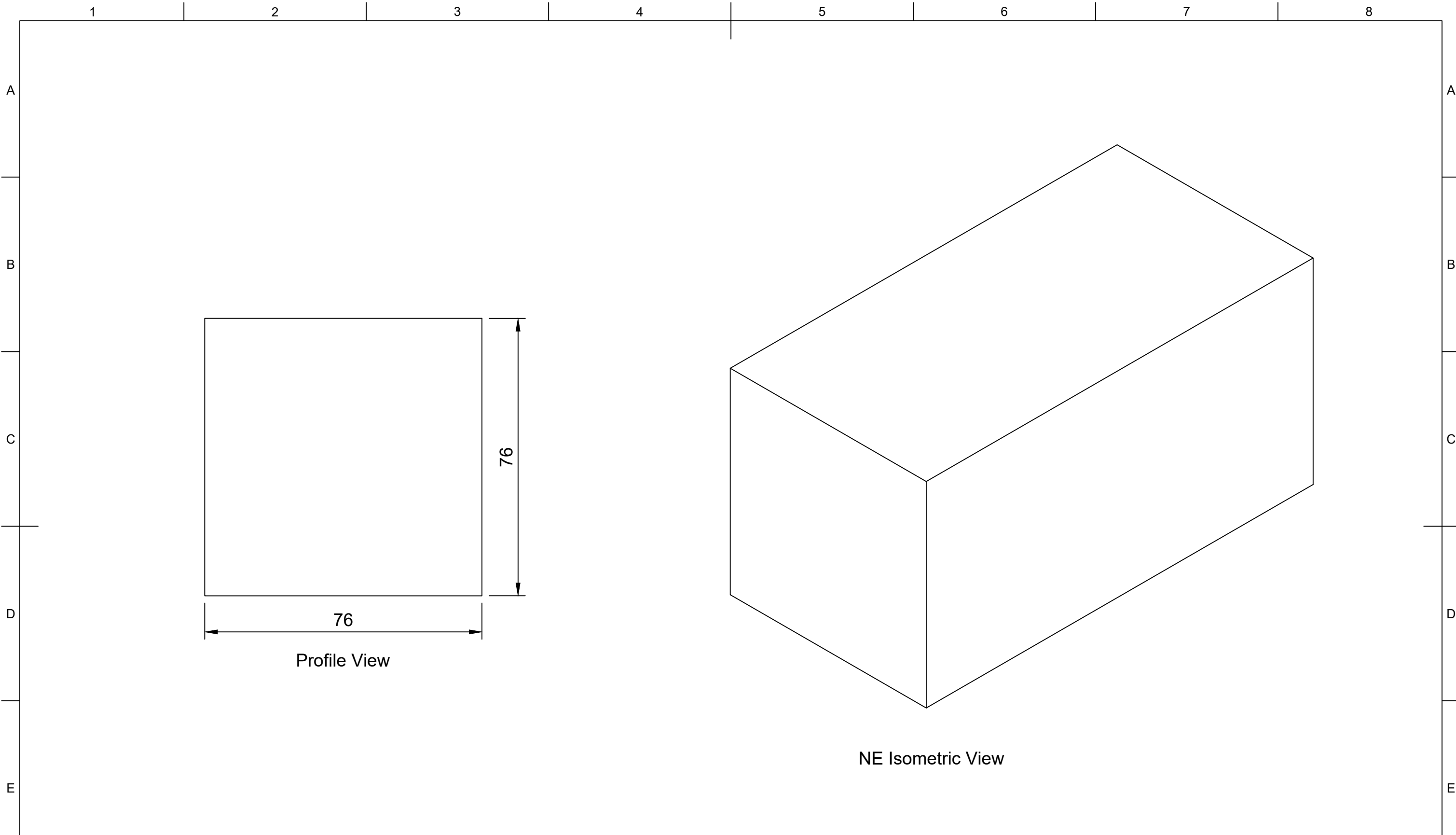

	Part Number				Created By		Cross Sectional Area (mm²)		Nominal Dimension (mm)		Tolerance, ± (mm)
	204411				Isaac Erskine		5776		Greater Than	Less Than or Equal to	
	Description				Date Drawn		Material				
	Square - Solid				28/07/2020		EPDM				
					Approved By		Hardness (Shore A)				
					Isaac Erskine		70				
					Date of Approval		Colour				
					28/02/22		Black				
					Projection		Weight (kg/m)				
					3rd Agl.		7.278				
Revision	Date of Issue	Sheet Scale	Sheet Size	Sheet							
A	28/02/22	1:1	A3	1/1							
								25.00	40.00	2.00	
								40.00	63.00	2.50	
								63.00	100.00	3.20	
								100.00		3.20%	

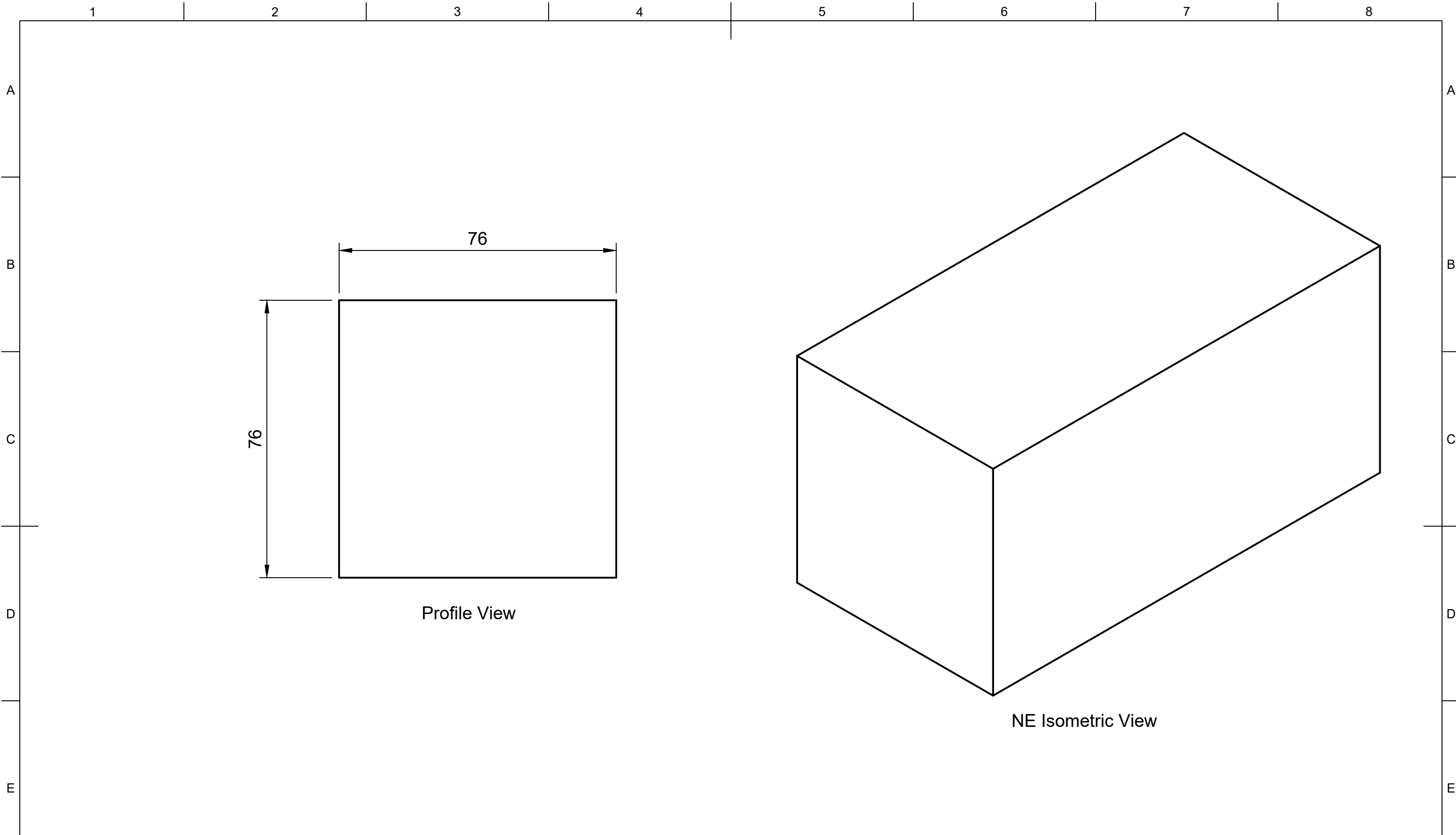

Profile View

NE Isometric View

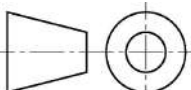
	Part Number				Created By		Cross Sectional Area (mm²)		Nominal Dimension (mm)		Tolerance, ± (mm)
	202306				Isaac Erskine		5776		Greater Than	Less Than or Equal to	
	Description				Date Drawn		Material		0.00		0.40
	Square - Solid				28/02/2022		Neoprene		1.50		0.50
	Revision				Approved By		Hardness (Shore A)		2.50		0.70
	A	28/02/22		Isaac Erskine		70		4.00		0.80	
	Date of Issue				Date of Approval		Colour		6.30		1.00
	1:1				28/02/22		Black		10.00		1.30
	Sheet Scale				Projection		Weight (kg/m)		16.00		1.60
	A3				3rd Agl. 		8.780		25.00		2.00
Sheet Size								40.00		2.50	
A3								63.00		3.20	
Sheet								100.00		3.20%	
1/1											

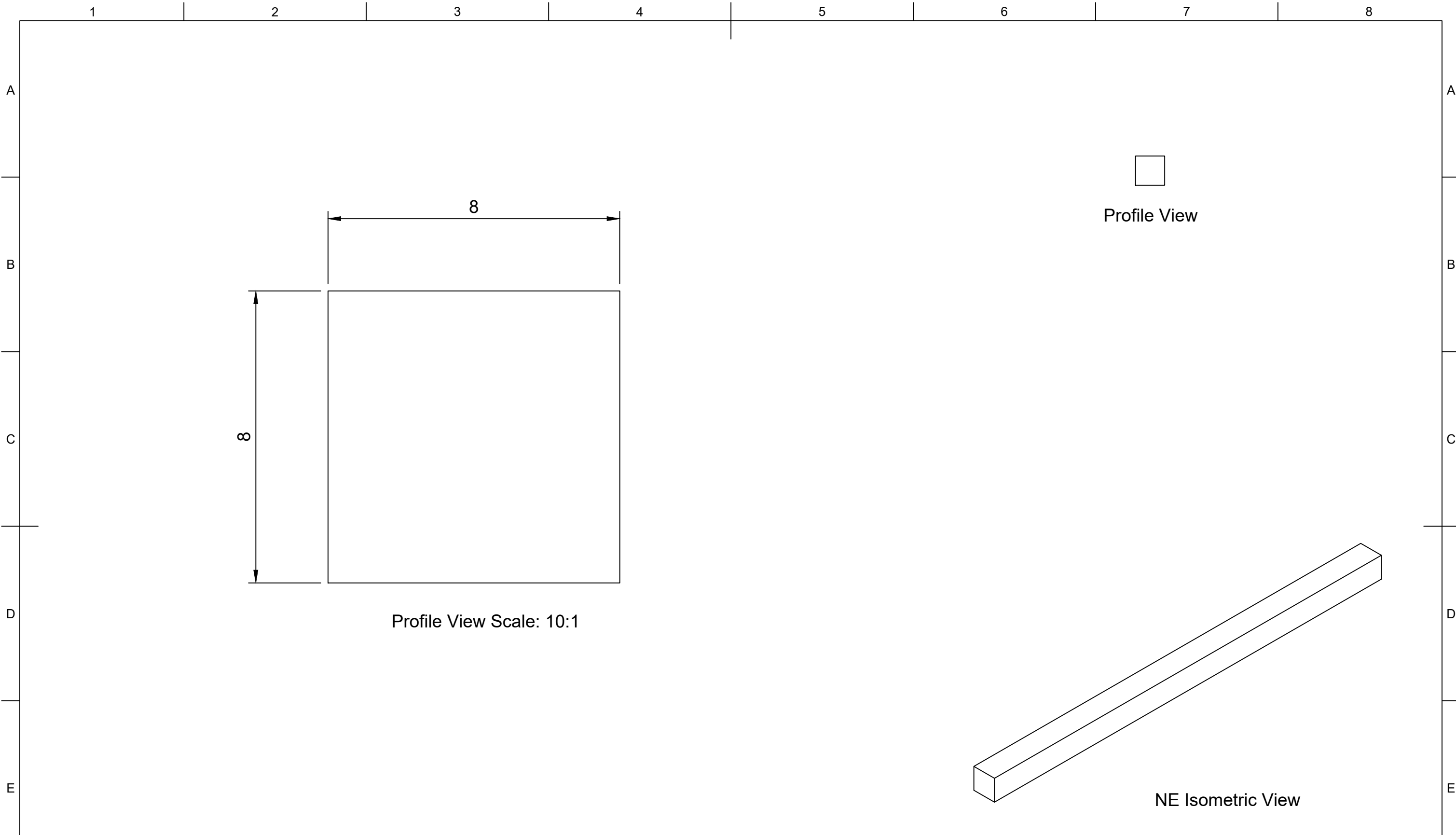

	Part Number				Created By		Cross Sectional Area (mm²)		Nominal Dimension (mm)		Tolerance, ± (mm)										
	206856				Isaac Erskine		64		Greater Than	Less Than or Equal to											
	Description				Date Drawn		Material		0.00		1.50	0.40									
					01/09/2020		EPDM		1.50		2.50	0.50									
	Square - Solid				Approved By		Hardness (Shore A)		2.50		4.00	0.70									
					Isaac Erskine		70		4.00		6.30	0.80									
	Revision				Date of Issue		Date of Approval		6.30		10.00	1.00									
					28/02/22		28/02/22		10.00		16.00	1.30									
	A		Sheet Scale		Sheet Size		Sheet		Projection		Weight (g/m)										
	1:1												A3		1/1		3rd Agl.		81		
28/02/22		1:1											A3		1/1		3rd Agl.		81		
28/02/22		1:1											A3		1/1		3rd Agl.		81		
28/02/22		1:1											A3		1/1		3rd Agl.		81		
28/02/22		1:1		A3		1/1		3rd Agl.		81											
28/02/22		1:1		A3		1/1		3rd Agl.		81											
28/02/22		1:1		A3		1/1		3rd Agl.		81											
28/02/22		1:1		A3		1/1		3rd Agl.		81											
28/02/22		1:1		A3		1/1		3rd Agl.		81											