

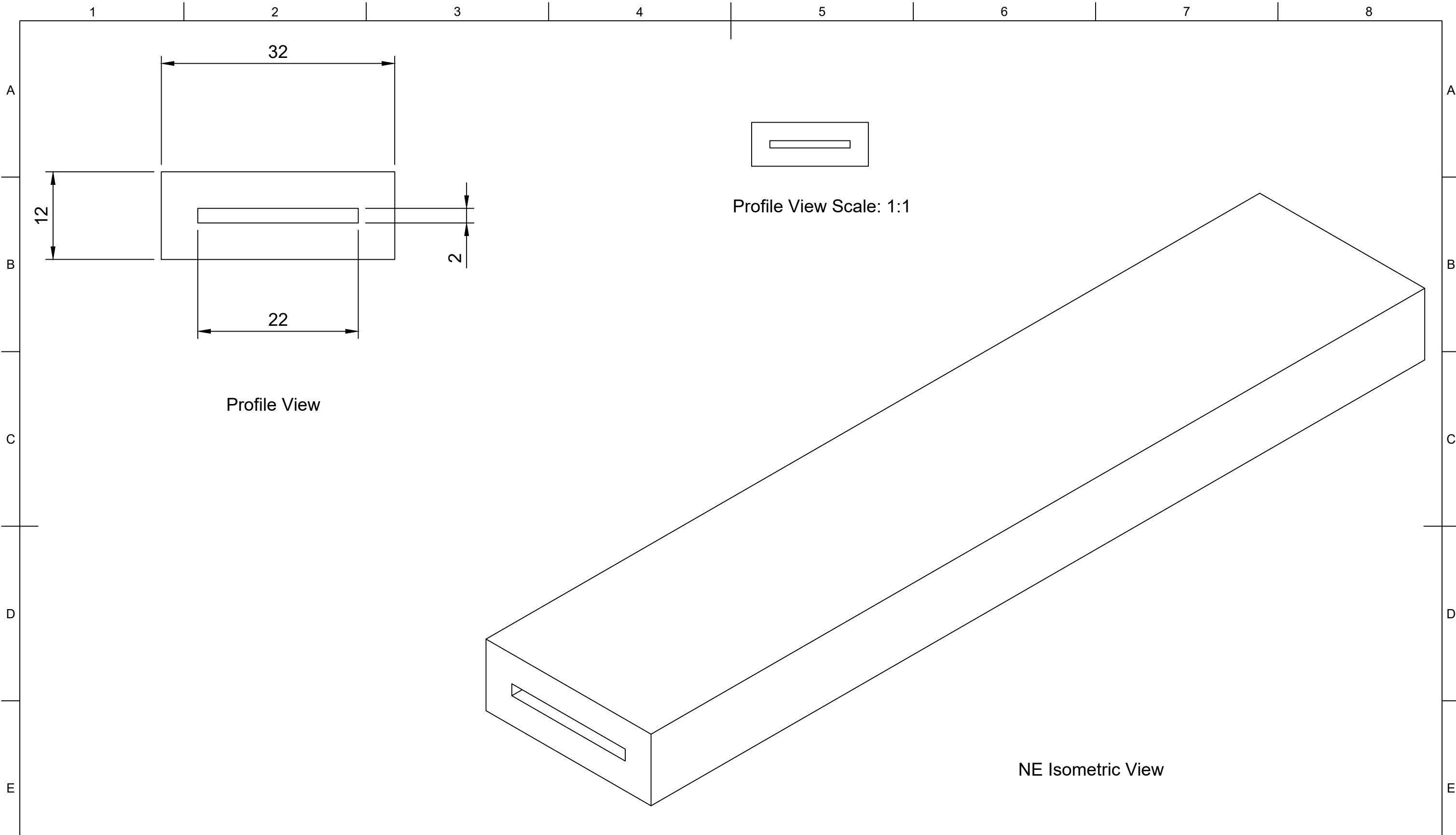

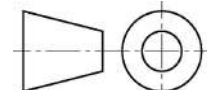

Rectangles

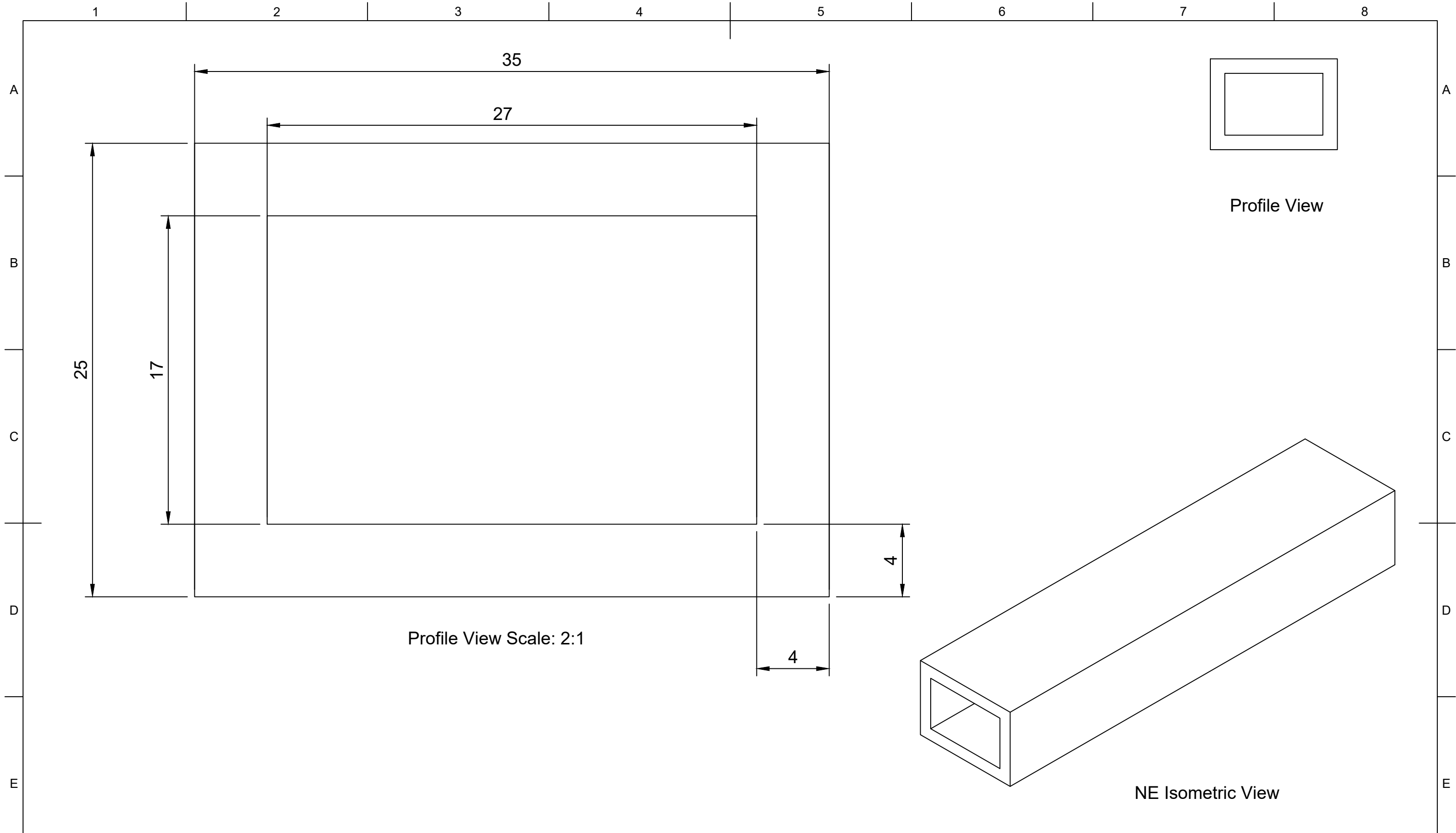

Part Number 200062		Created By David Stirling		Cross Sectional Area (mm²) 340		Nominal Dimension (mm)		Tolerance, ± (mm)
		Date Drawn 11/04/2020		Material EPDM		Greater Than	Less Than or Equal to	
Description Rectangle - Hollow		Approved By		Hardness (Shore A) 70		0.00	1.50	0.40
		Date of Approval		Colour Black		1.50	2.50	0.50
		Projection 3rd Agl. 		Weight (g/m) 422		2.50	4.00	0.70
Revision A	Date of Issue 13/01/2022	Sheet Scale 2:1	Sheet Size A3	Sheet 1/1		6.30	10.00	1.00
						10.00	16.00	1.30
						16.00	25.00	1.60
						25.00	40.00	2.00
						40.00	63.00	2.50
						63.00	100.00	3.20
						100.00		3.20%

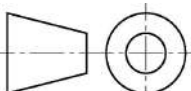

	Part Number				Created By		Cross Sectional Area (mm²)		Nominal Dimension (mm)		Tolerance, ± (mm)
	208594				Isaac Erskine		416		Greater Than	Less Than or Equal to	
	Description				Date Drawn		Material		0.00	1.50	0.40
	Rectangle - Hollow				10/08/2020		Neoprene		1.50	2.50	0.50
	Revision				Approved By		Hardness (Shore A)		2.50	4.00	0.70
	A	15/02/2022		1:1	Isaac Erskine		70		4.00	6.30	0.80
	Date of Issue		Sheet Scale		Sheet Size		Colour		6.30	10.00	1.00
	15/02/2022		1:1		A3		Black		10.00	16.00	1.30
	Sheet		Projection		Date of Approval		Weight (g/m)		16.00	25.00	1.60
	1/1		3rd Agl. 		15/02/2022		632		25.00	40.00	2.00
								40.00	63.00	2.50	
								63.00	100.00	3.20	
								100.00		3.20%	

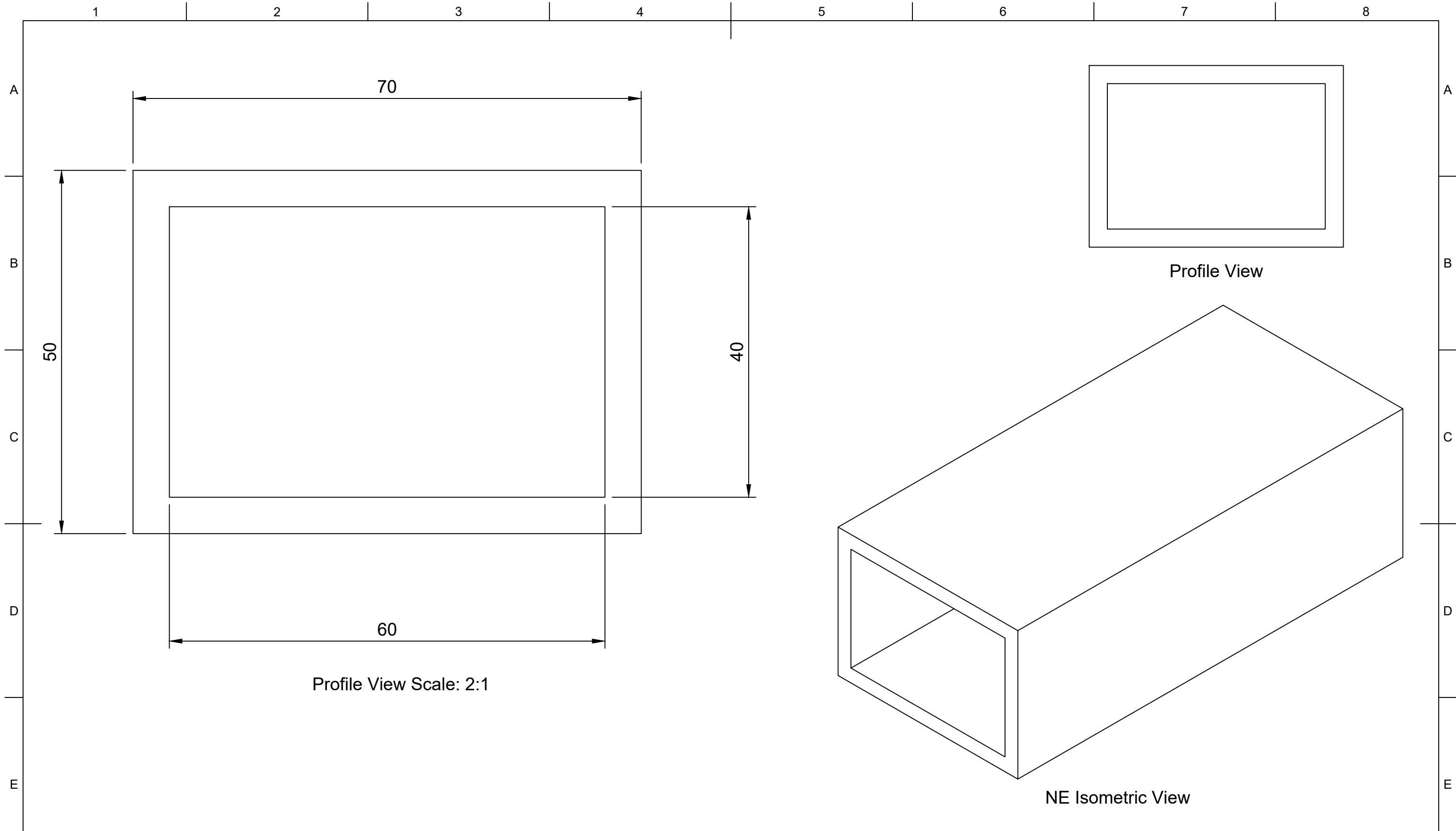

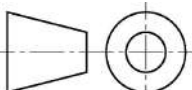
	Part Number				Created By		Cross Sectional Area (mm²)		Nominal Dimension (mm)		Tolerance, ± (mm)
	205316				Isaac Erskine		1100		Greater Than	Less Than or Equal to	
	Description				Date Drawn		Material		0.00	1.50	0.40
	Rectangle - Hollow				11/08/2020		EPDM		1.50	2.50	0.50
	Revision				Approved By		Hardness (Shore A)		2.50	4.00	0.70
	A	17/02/2022		1:1	Isaac Erskine		70		4.00	6.30	0.80
	Date of Issue		Sheet Scale		Sheet Size		Colour		6.30	10.00	1.00
	17/02/2022		1:1		A3		Black		10.00	16.00	1.30
	Sheet		Projection		Weight (g/m)				16.00	25.00	1.60
	1/1		3rd Agl. 		1.386				25.00	40.00	2.00
								40.00	63.00	2.50	
								63.00	100.00	3.20	
								100.00		3.20%	

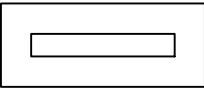
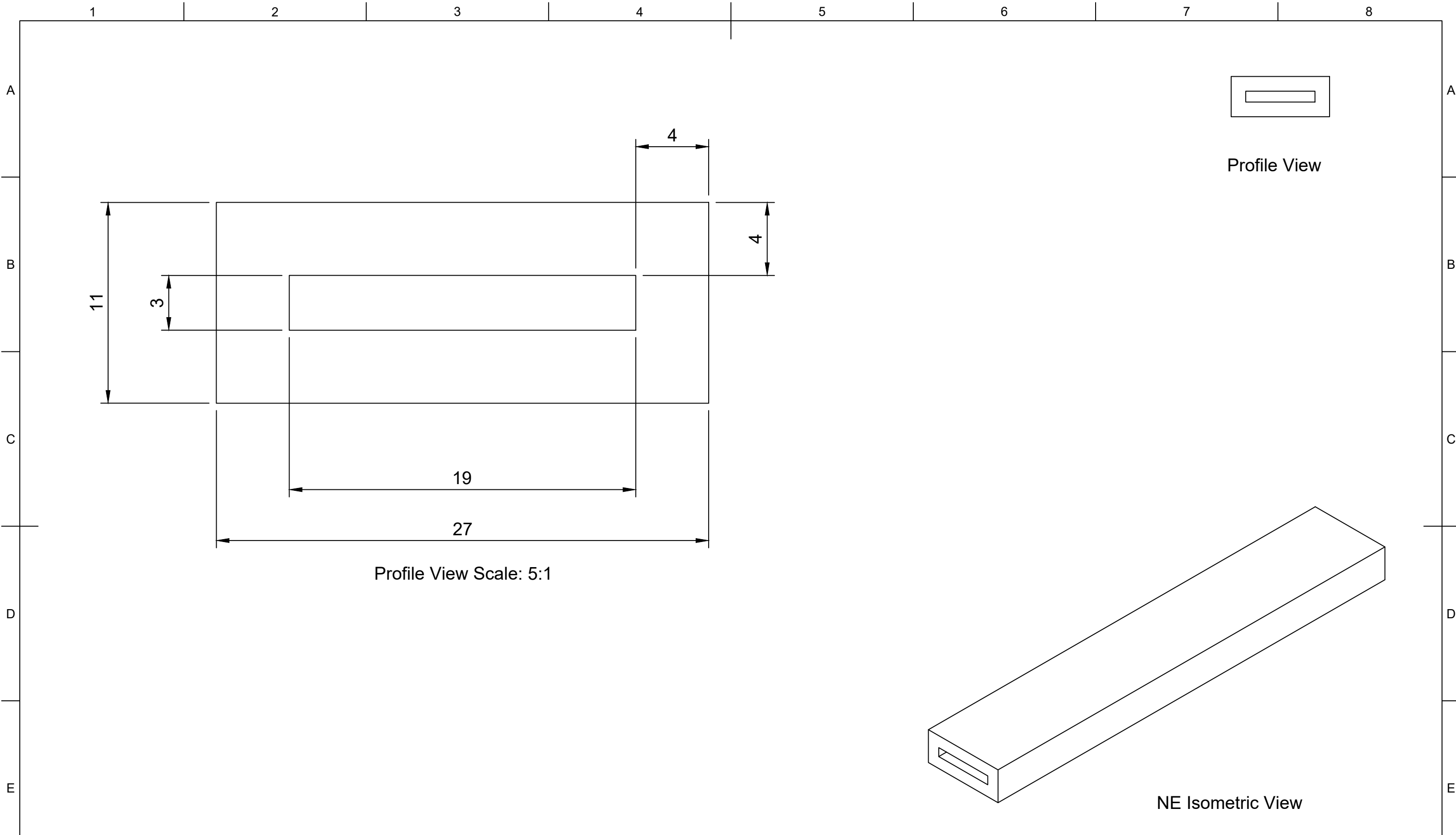

Profile View

Profile View Scale: 5:1

NE Isometric View



	Part Number				Created By		Cross Sectional Area (mm²)		Nominal Dimension (mm)		Tolerance, ± (mm)	
	207241				Isaac Erskine		240		Greater Than	Less Than or Equal to		
	Description				Date Drawn		Material		0.00		0.40	
	Rectangle - Hollow				18/08/2020		EPDM		1.50		0.50	
	Revision				Approved By		Hardness (Shore A)		2.50		0.70	
	A	Date of Issue		Sheet Scale		Isaac Erskine		Colour		4.00		0.80
		17/02/2022		1:1		17/02/2022		Black		6.30		1.00
				Sheet Size		Date of Approval		Weight (g/m)		10.00		1.30
				A3		17/02/2022		302		16.00		1.60
				Sheet		Projection		3rd Agl.		25.00		2.00
			1/1						40.00		2.50	
									63.00		3.20	
									100.00		3.20%	

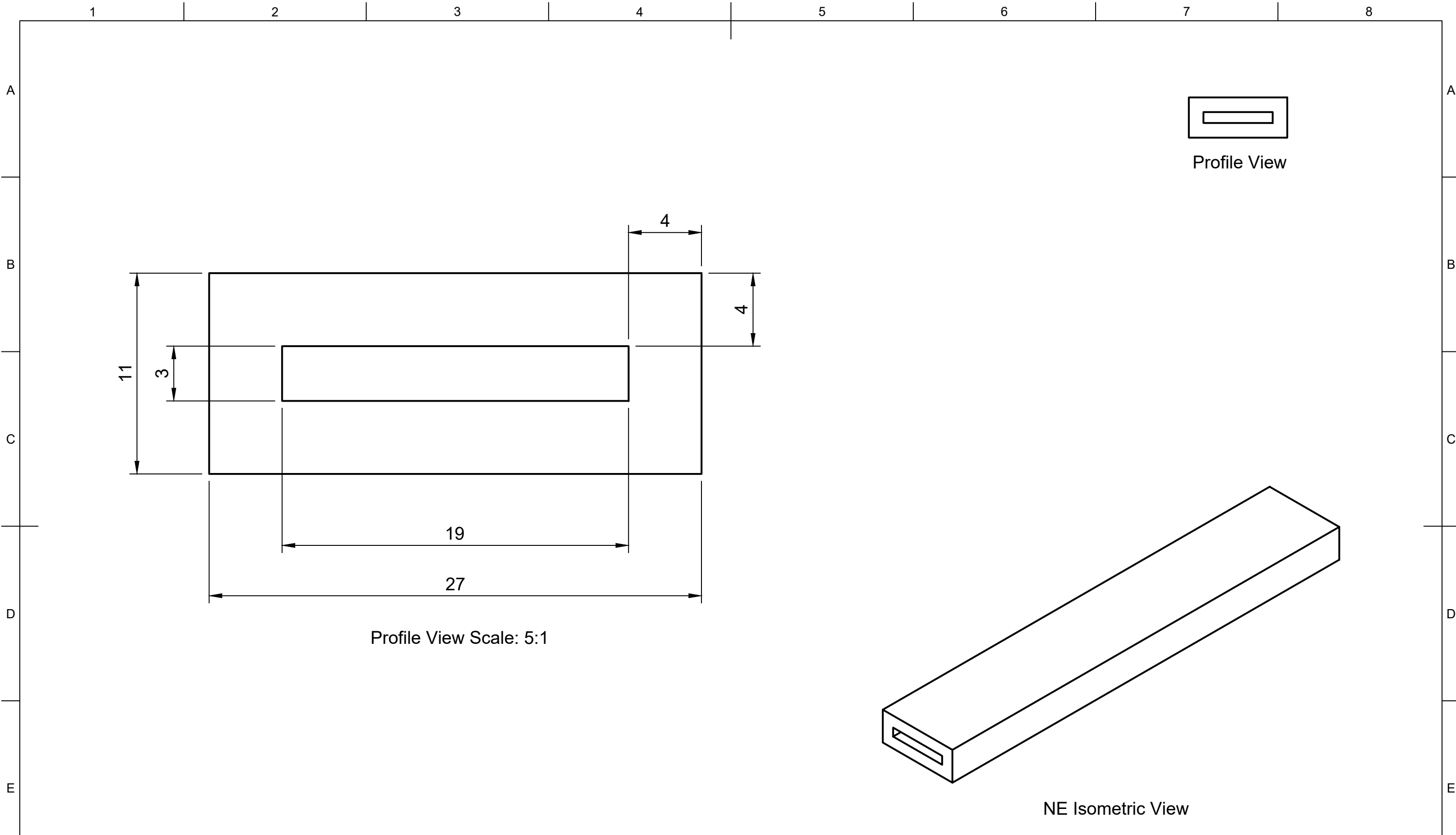

	Part Number				Created By		Cross Sectional Area (mm²)		Nominal Dimension (mm)		Tolerance, ± (mm)	
	204710				Isaac Erskine		240		Greater Than	Less Than or Equal to		
	Description				Date Drawn		Material		0.00	1.50	0.40	
	Rectangle - Hollow				17/02/2022		Neoprene		1.50	2.50	0.50	
	Revision				Approved By		Hardness (Shore A)		2.50	4.00	0.70	
	A	Date of Issue		Sheet Scale		Isaac Erskine		70		4.00	6.30	0.80
		17/02/2022		1:1		Date of Approval		Black		6.30	10.00	1.00
				A3		17/02/2022		Weight (g/m)		10.00	16.00	1.30
				1/1		Projection		365		16.00	25.00	1.60
						3rd Agl.				25.00	40.00	2.00
									40.00	63.00	2.50	
									63.00	100.00	3.20	
									100.00		3.20%	

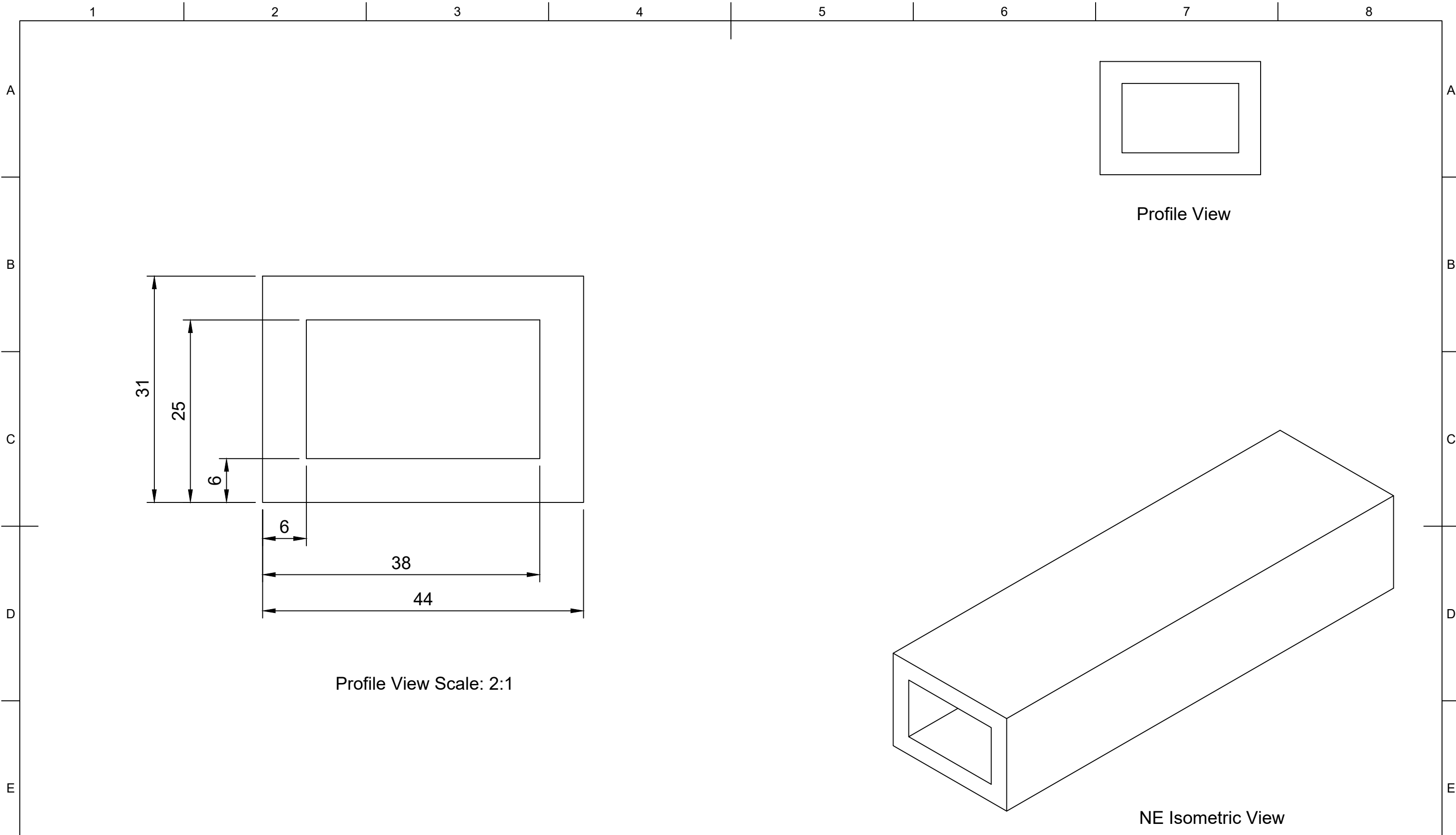

Profile View Scale: 2:1

NE Isometric View

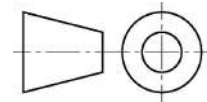
	Part Number				Created By		Cross Sectional Area (mm²)		Nominal Dimension (mm)		Tolerance, ± (mm)
	200385				Isaac Erskine		756		Greater Than	Less Than or Equal to	
					Date Drawn		Material		0.00	1.50	0.40
					31/08/2020		Neoprene		1.50	2.50	0.50
	Description				Approved By		Hardness (Shore A)		2.50	4.00	0.70
	Rectangle - Hollow				Isaac Erskine		70		4.00	6.30	0.80
					Date of Approval		Colour		6.30	10.00	1.00
					24/02/2022		Black		10.00	16.00	1.30
									16.00	25.00	1.60
									25.00	40.00	2.00
Revision	Date of Issue	Sheet Scale	Sheet Size	Sheet	Projection	Weight (kg/m)		40.00	63.00	2.50	
A	24/02/2022	1:1	A3	1/1	3rd Agl. 	1.149		63.00	100.00	3.20	
								100.00		3.20%	

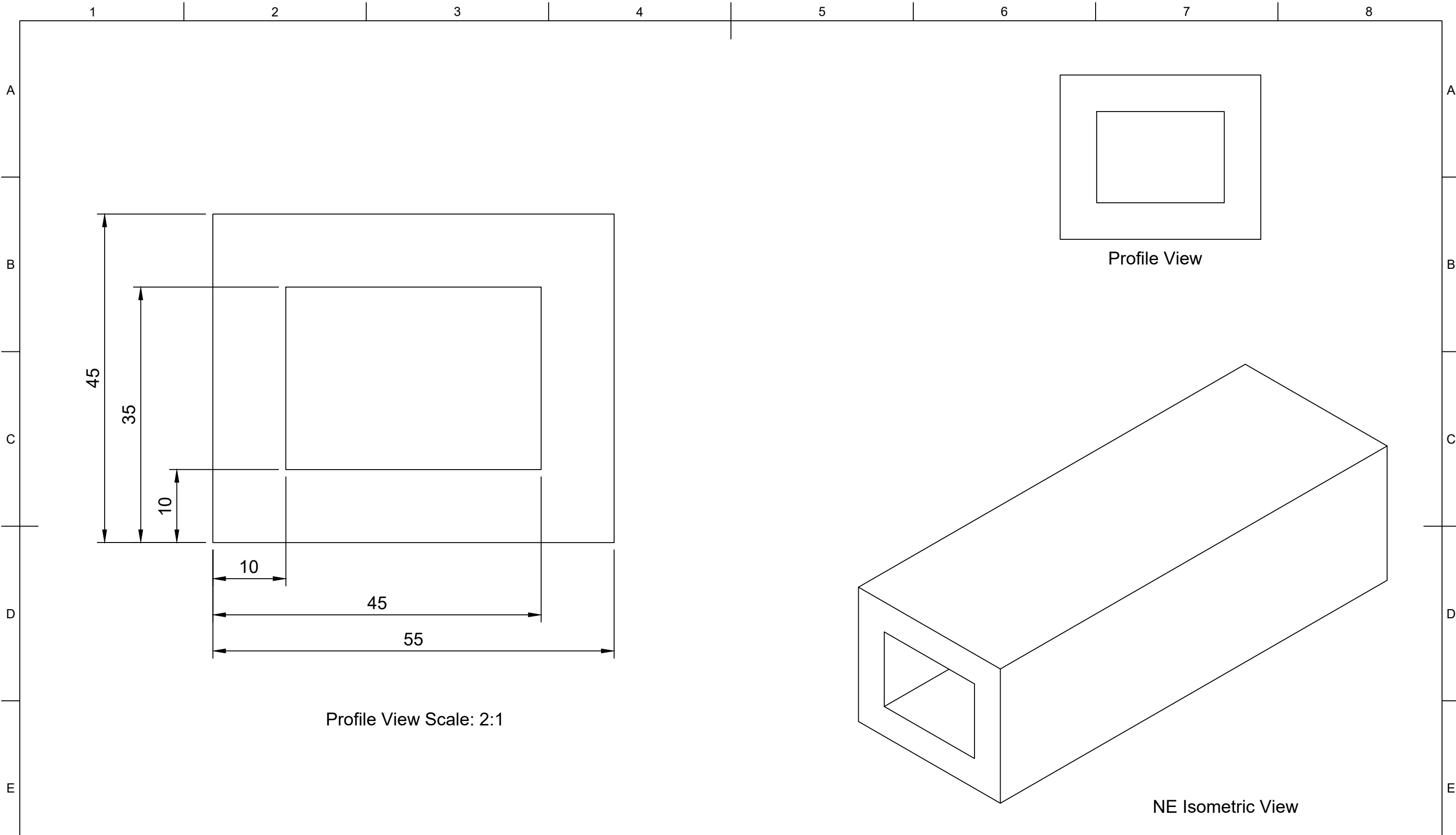

	Part Number				Created By		Cross Sectional Area (mm²)		Nominal Dimension (mm)		Tolerance, ± (mm)	
	201479				Isaac Erskine		1600		Greater Than	Less Than or Equal to		
	Description				Date Drawn		Material		0.00		0.40	
	Rectangle - Hollow				05/09/2020		EPDM		1.50		0.50	
	Revision				Approved By		Hardness (Shore A)		2.50		0.70	
	A	Date of Issue		Sheet Scale		Isaac Erskine		Colour		4.00		0.80
		28/02/2022		1:1		28/02/2022		Black		6.30		1.00
				Sheet Size		Date of Approval		Weight (kg/m)		10.00		1.30
				A3		28/02/2022		2.016		16.00		1.60
				Sheet		Projection				25.00		2.00
			1/1		3rd Ang.				40.00		2.50	
									63.00		3.20	
									100.00		3.20%	

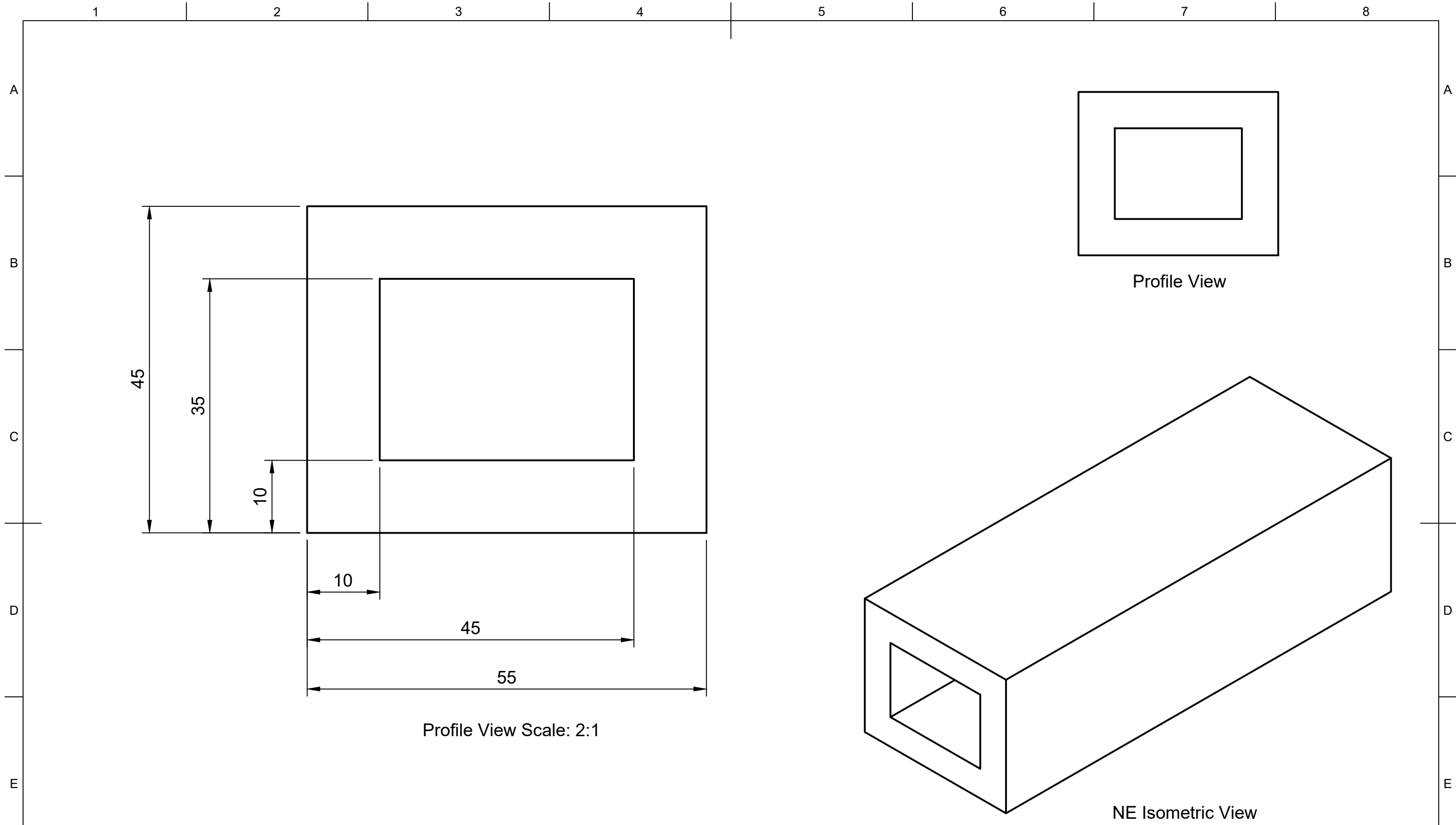

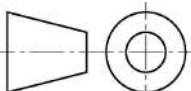
	Part Number				Created By		Cross Sectional Area (mm²)		Nominal Dimension (mm)		Tolerance, ± (mm)	
	201353				Isaac Erskine		1600		Greater Than	Less Than or Equal to		
	Description				Date Drawn		Material		0.00		0.40	
	Rectangle - Hollow				05/09/2020		Neoprene		1.50		0.50	
	Revision				Approved By		Hardness (Shore A)		2.50		0.70	
	A	Date of Issue		Sheet Scale		Isaac Erskine		Colour		4.00		0.80
		28/02/2022		1:1		28/02/2022		Black		6.30		1.00
				A3		Projection		Weight (kg/m)		10.00		1.30
				1/1		3rd Agl. 		2.432		16.00		1.60
										25.00		2.00
									40.00		2.50	
									63.00		3.20	
									100.00		3.20%	

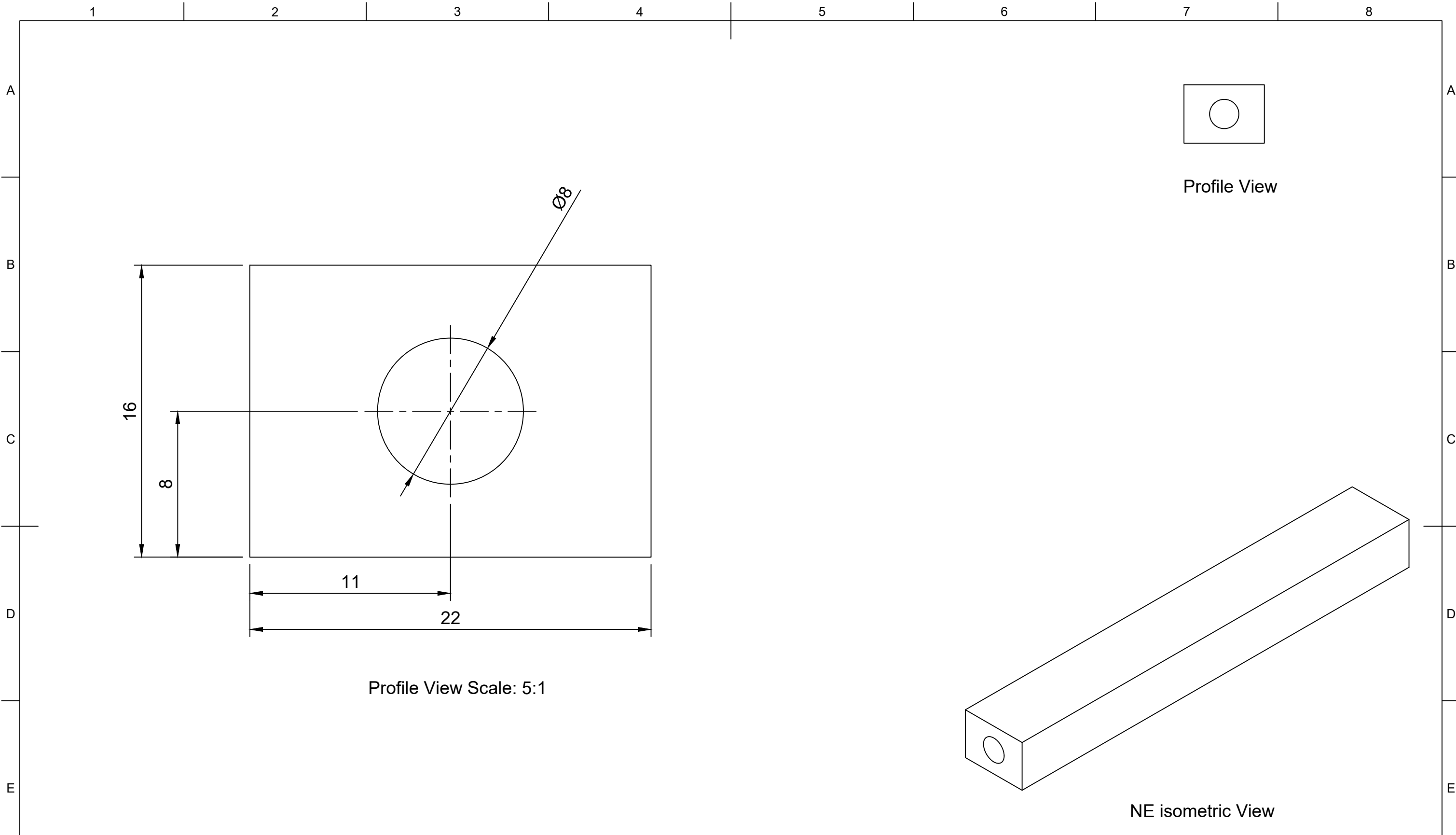

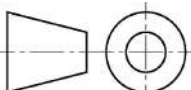
	Part Number				Created By		Cross Sectional Area (mm²)		Nominal Dimension (mm)		Tolerance, ± (mm)
	203476				David Stirling		302		Greater Than	Less Than or Equal to	
	Description				Date Drawn		Material		0.00	1.50	0.40
	Rectangle - Round Centre				06/07/2020		Neoprene		1.50	2.50	0.50
	Revision				Approved By		Hardness (Shore A)		2.50	4.00	0.70
	A	Date of Issue		Sheet Scale	Sheet Size	Sheet	70		4.00	6.30	0.80
		27/01/2022		1:1	A3	1/1	Date of Approval		6.30	10.00	1.00
							Colour		10.00	16.00	1.30
							Projection		16.00	25.00	1.60
							3rd Agl. 		25.00	40.00	2.00
						Weight (g/m)		40.00	63.00	2.50	
						459		63.00	100.00	3.20	
								100.00		3.20%	

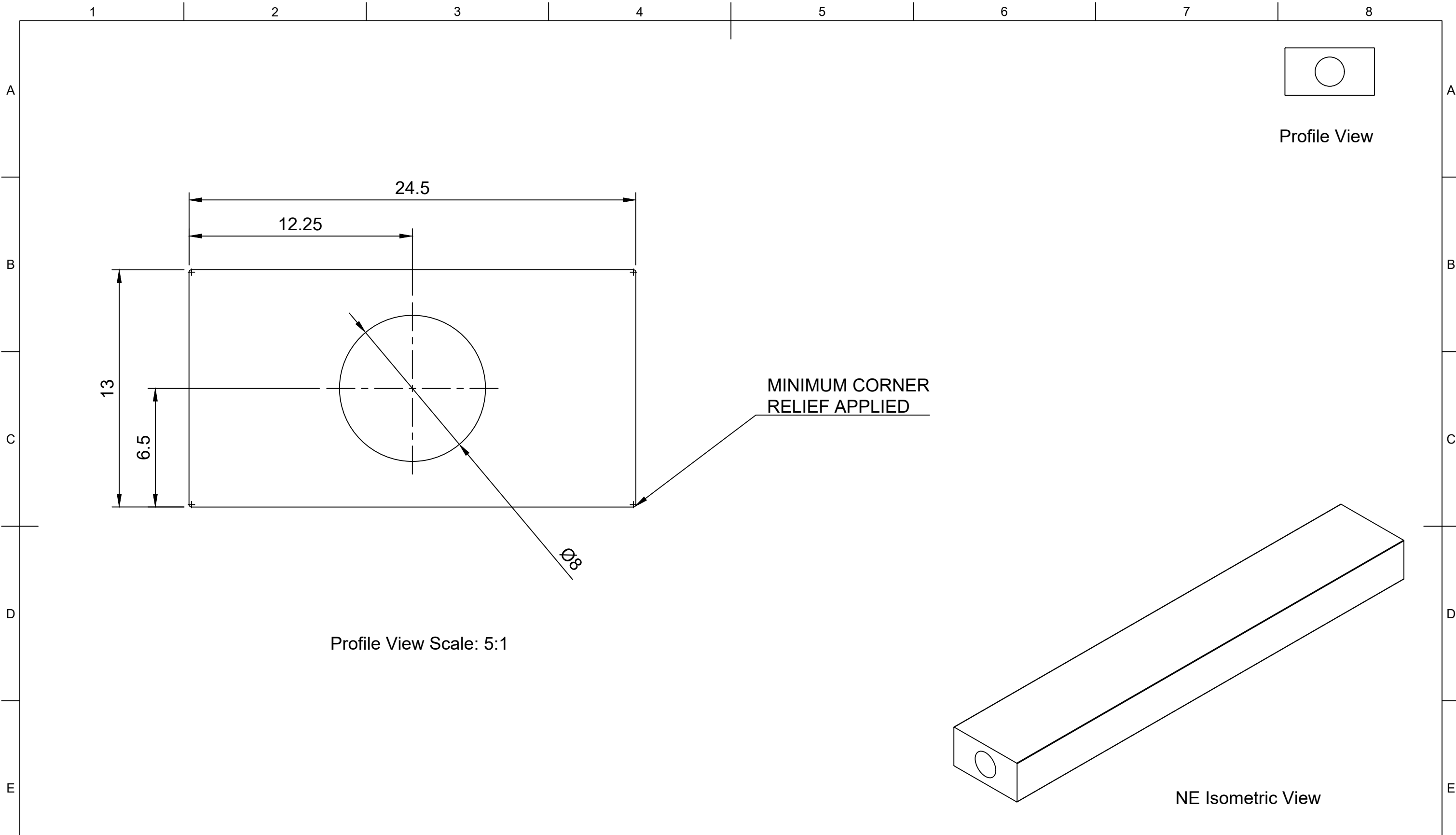

	Part Number				Created By		Cross Sectional Area (mm ²)		Nominal Dimension (mm)		Tolerance, ± (mm)
	203321				Isaac Erskine		268		Greater Than	Less Than or Equal to	
	Description				Date Drawn		Material		0.00	1.50	0.40
	Rectangle - Round Centre				31/07/2020		EPDM		1.50	2.50	0.50
	Revision				Approved By		Hardness (Shore A)		2.50	4.00	0.70
	A	Date of Issue		Sheet Scale	Sheet Size	Sheet	Isaac Erskine		4.00	6.30	0.80
		15/02/2022		1:1	A3	1/1	Date of Approval		6.30	10.00	1.00
							15/02/2022		10.00	16.00	1.30
	Projection				3rd Agl.		Colour		16.00	25.00	1.60
							Black		25.00	40.00	2.00
						Weight (g/m)		40.00	63.00	2.50	
						338		63.00	100.00	3.20	
								100.00		3.20%	

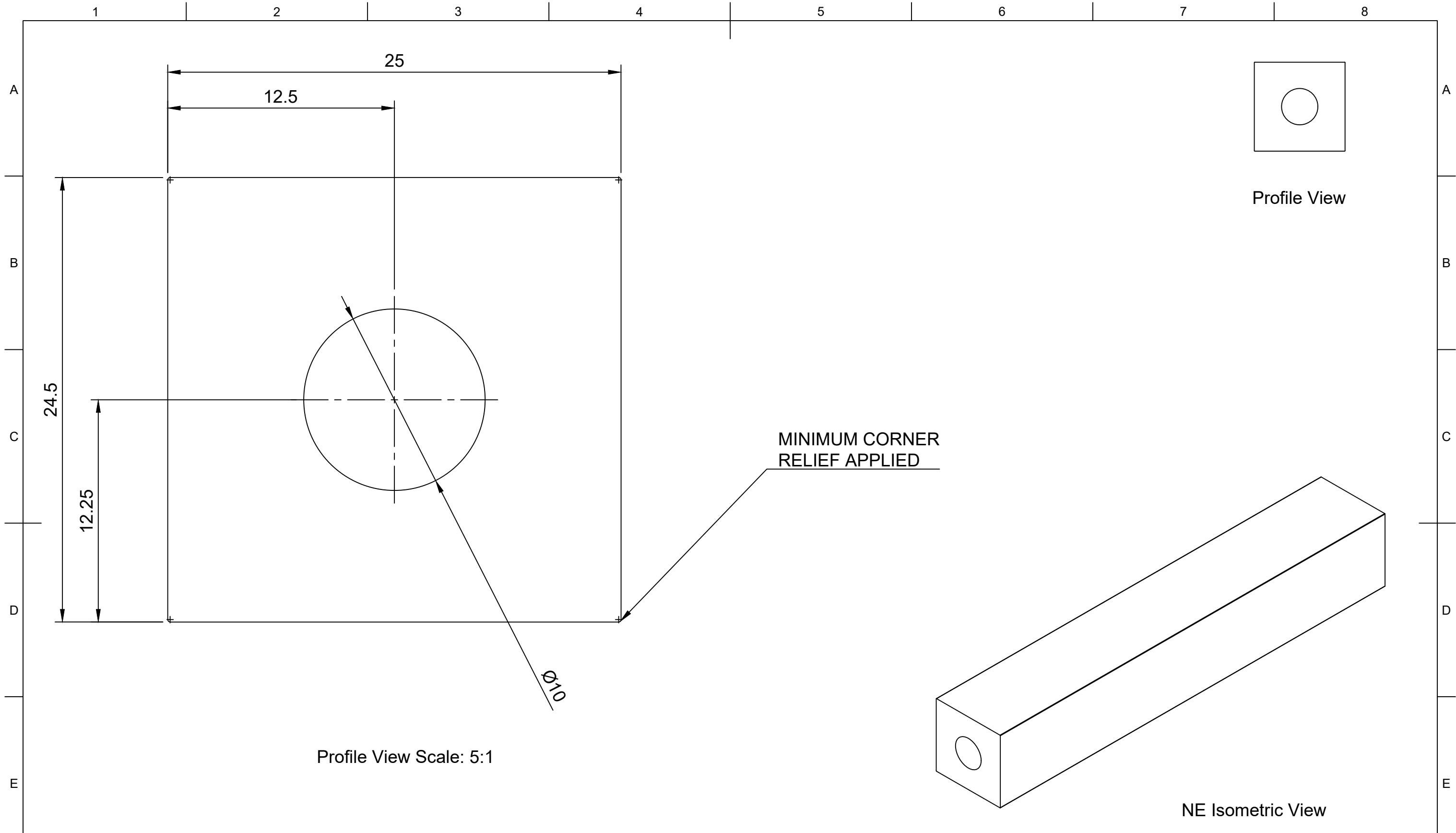

Part Number		200550			Created By	Isaac Erskine	Cross Sectional Area (mm ²)	534		Nominal Dimension (mm)		Tolerance, ± (mm)
					Date Drawn	31/07/2020	Material	EPDM	Greater Than	Less Than or Equal to		
Description		Rectangle - Round Centre			Approved By	Isaac Erskine	Hardness (Shore A)	70		0.00	1.50	0.40
					Date of Approval	15/02/2022	Colour	Black	1.50	2.50	0.50	
Revision	Date of Issue	Sheet Scale	Sheet Size	Sheet	Projection	3rd Agl.	Weight (g/m)	673		2.50	4.00	0.70
A	15/02/2022	1:1	A3	1/1			25.00	40.00	2.00			
										63.00	100.00	3.20
										100.00		3.20%

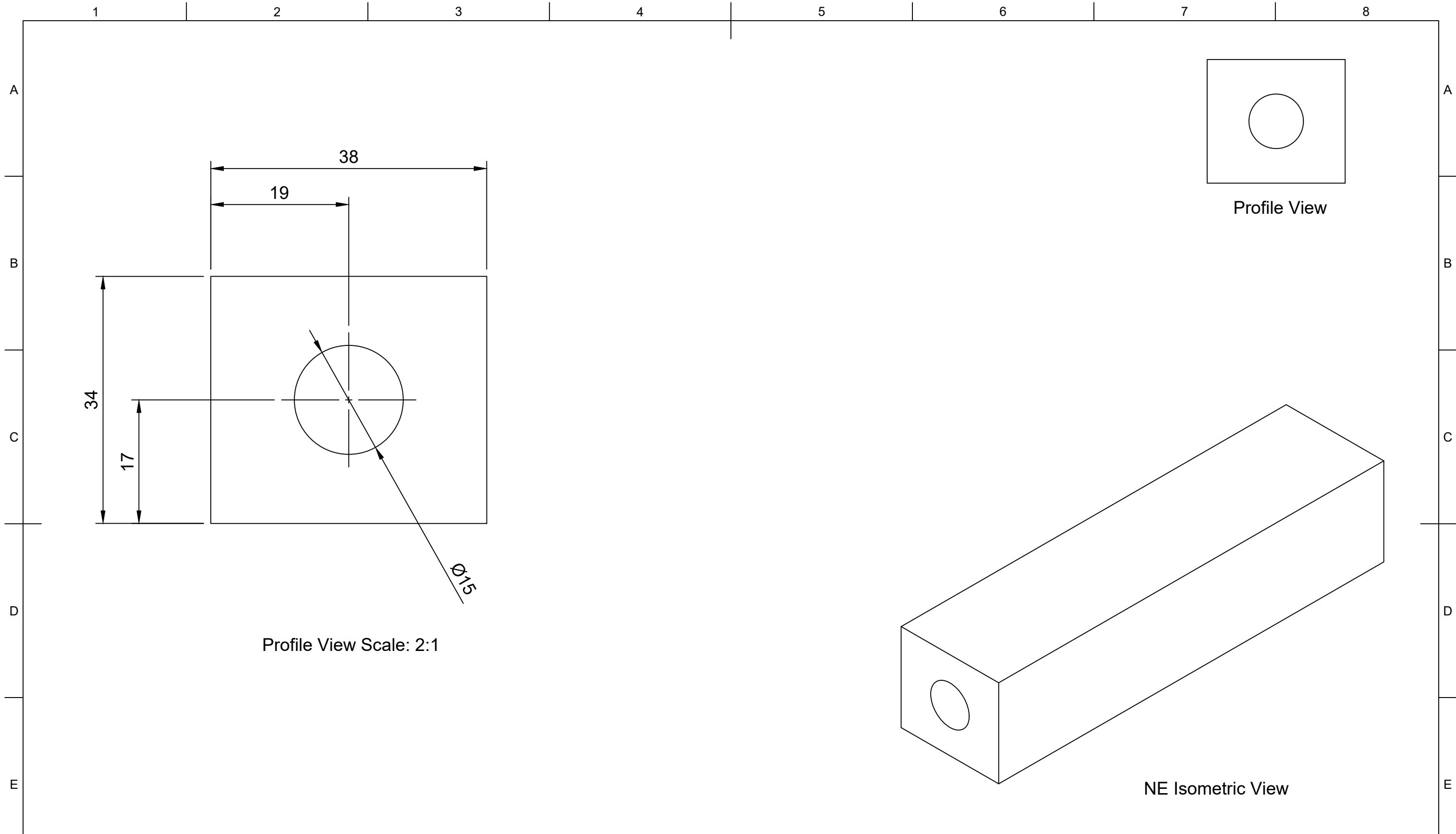

Part Number 204698					Created By Isaac Erskine		Cross Sectional Area (mm ²) 1115		Nominal Dimension (mm)		Tolerance, ± (mm)				
					Date Drawn 10/08/2020		Material Nitrile		Greater Than	Less Than or Equal to					
Description Rectangle - Round Centre					Approved By Isaac Erskine		Hardness (Shore A) 70		0.00	1.50	0.40				
					Date of Approval 15/02/2022		Colour Black		1.50	2.50	0.50				
					Revision A		Date of Issue 15/02/2022		Sheet Scale 1:1		Sheet Size A3		Sheet 1/1		2.50
					Projection 3rd Agl.		Projection Diagram		Weight (kg/m) 1.349		2.50	40.00	2.00		
						40.00	63.00	2.50							
						63.00	100.00	3.20							
						100.00		3.20%							

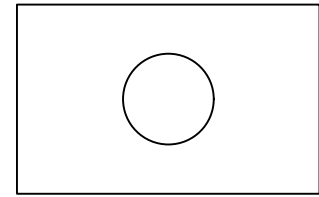
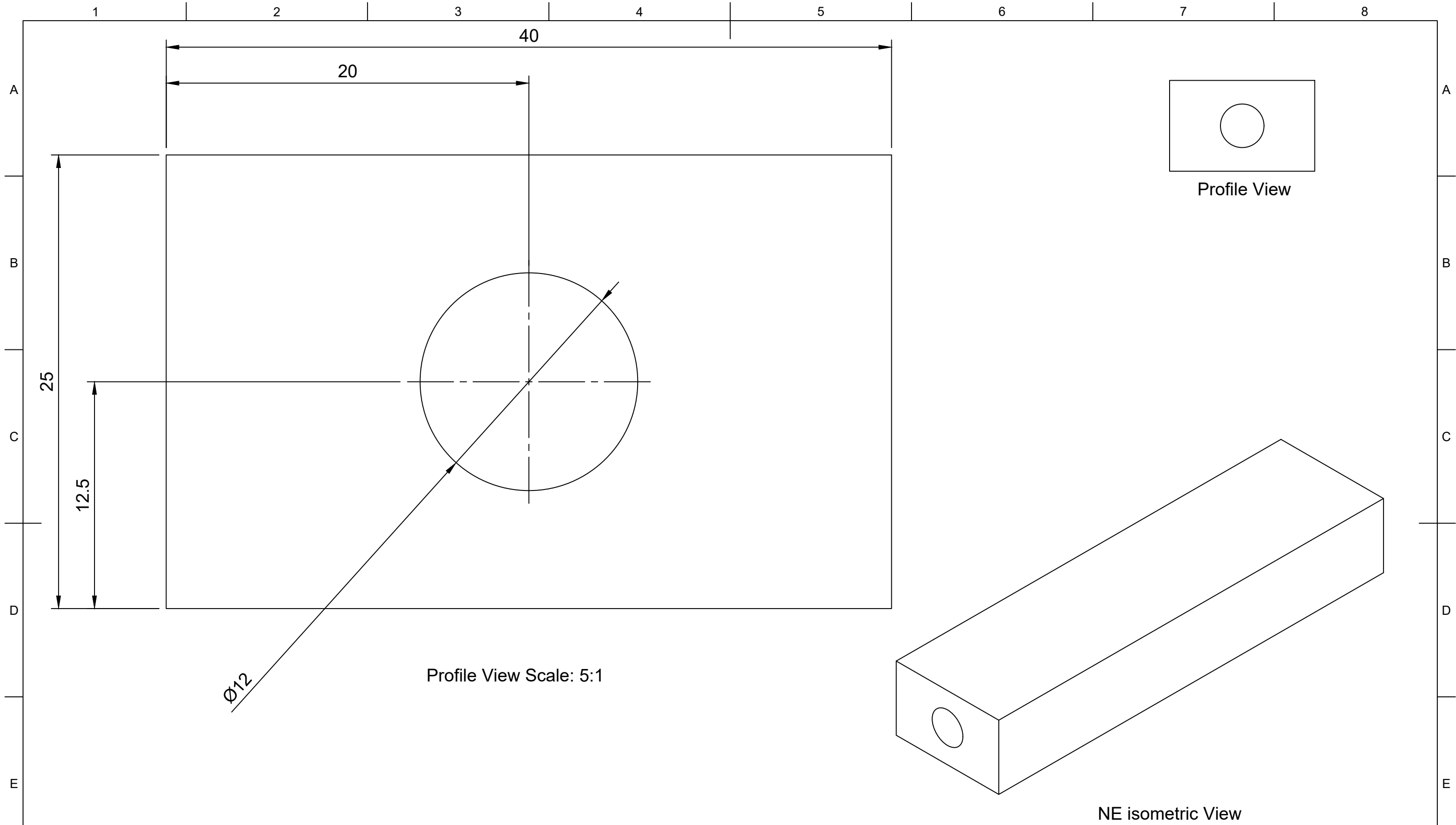

Profile View

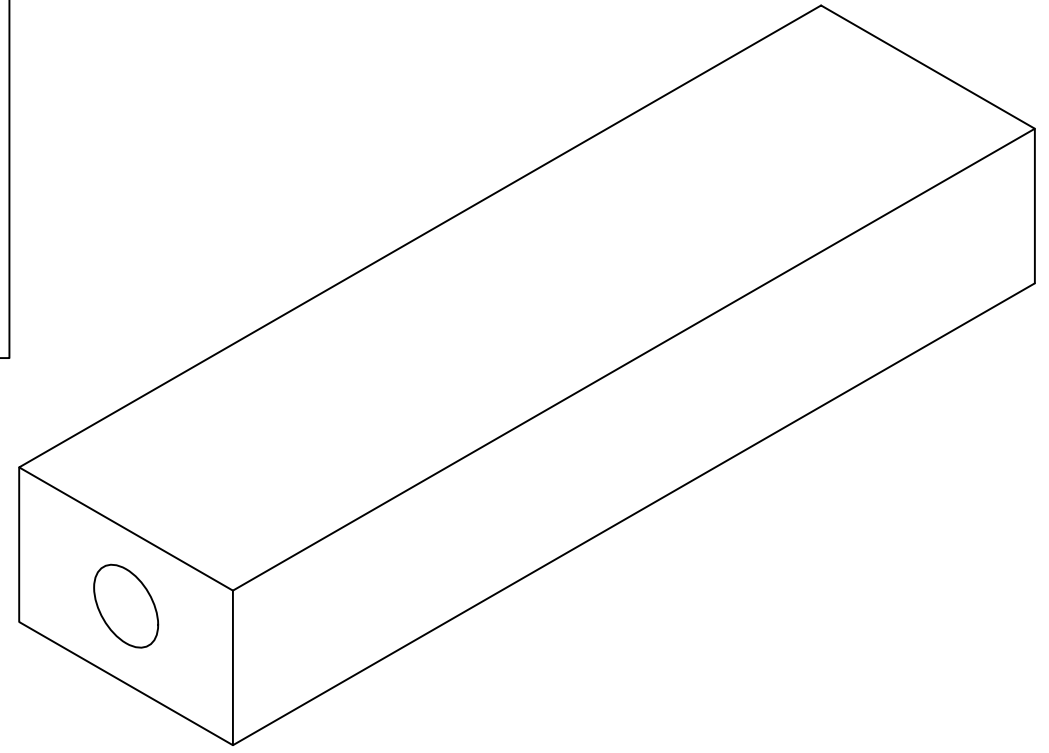

NE isometric View



Part Number		207297			Created By	Isaac Erskine	Cross Sectional Area (mm ²)	887		Nominal Dimension (mm)		Tolerance, ± (mm)
					Date Drawn	10/08/2020	Material	EPDM	Greater Than	Less Than or Equal to		
Description		Rectangle - Round Centre			Approved By	Isaac Erskine	Hardness (Shore A)	70		0.00	1.50	0.40
					Date of Approval	15/02/2022	Colour	Black	1.50	2.50	0.50	
Revision	Date of Issue	Sheet Scale	Sheet Size	Sheet	Projection	3rd Agl.	Weight (g/m)	1.118		2.50	4.00	0.70
A	15/02/2022	1:1	A3	1/1	25.00		40.00	2.00				
										40.00	63.00	2.50
										63.00	100.00	3.20
										100.00		3.20%

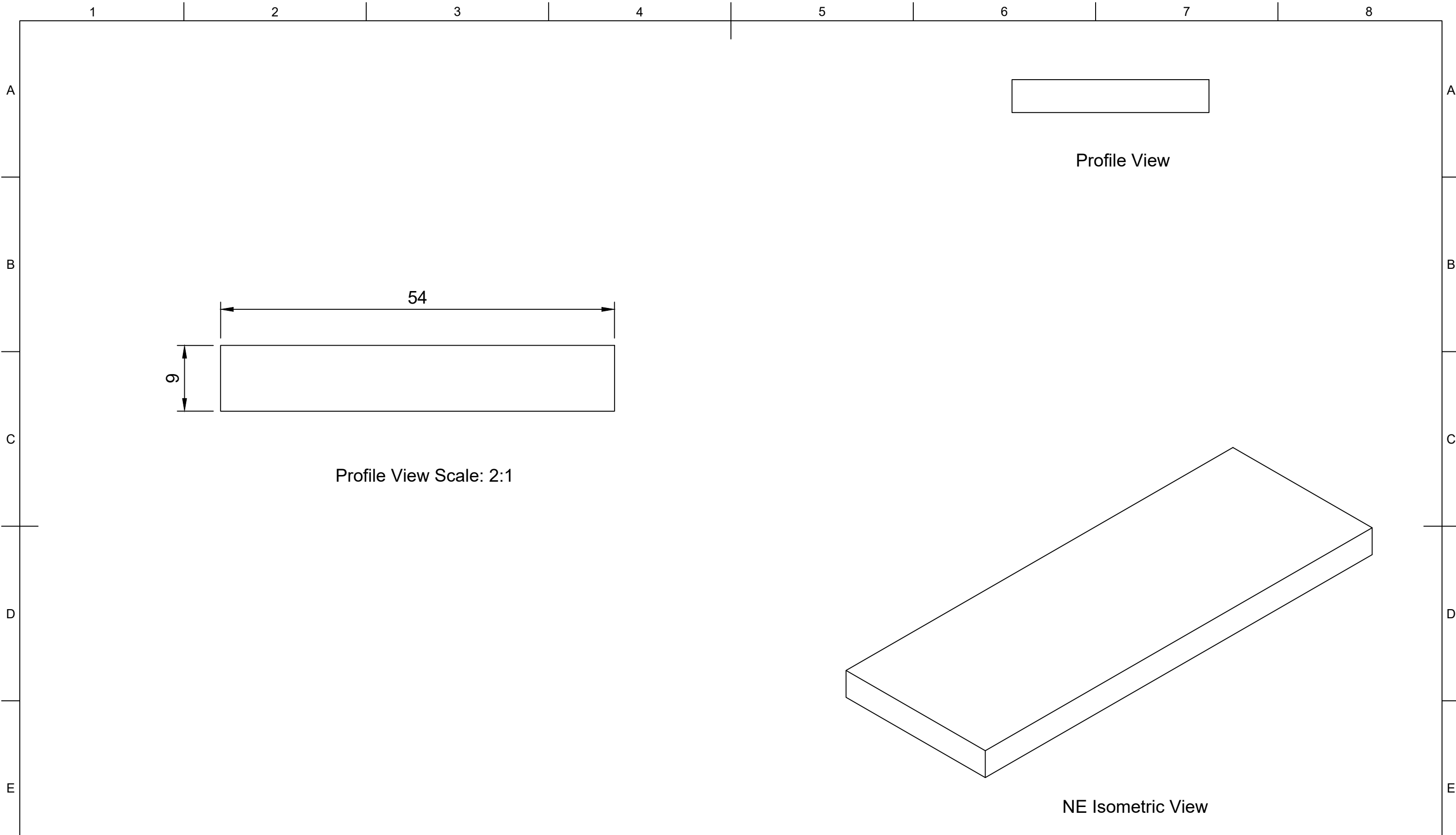

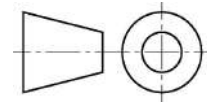
	Part Number				Created By		Cross Sectional Area (mm²)		Nominal Dimension (mm)		Tolerance, ± (mm)
	200879				David Stirling		486		Greater Than	Less Than or Equal to	
					Date Drawn		Material		0.00	1.50	0.40
					30/05/2020		EPDM		1.50	2.50	0.50
	Description				Approved By		Hardness (Shore A)		2.50	4.00	0.70
	Rectangle - Solid						70		4.00	6.30	0.80
					Date of Approval		Colour		6.30	10.00	1.00
							Black		10.00	16.00	1.30
							Weight (g/m)		16.00	25.00	1.60
							612		25.00	40.00	2.00
Revision	Date of Issue	Sheet Scale	Sheet Size	Sheet	Projection			40.00	63.00	2.50	
A	24/01/2022	1:1	A3	1/1	3rd Agl.			63.00	100.00	3.20	
								100.00		3.20%	

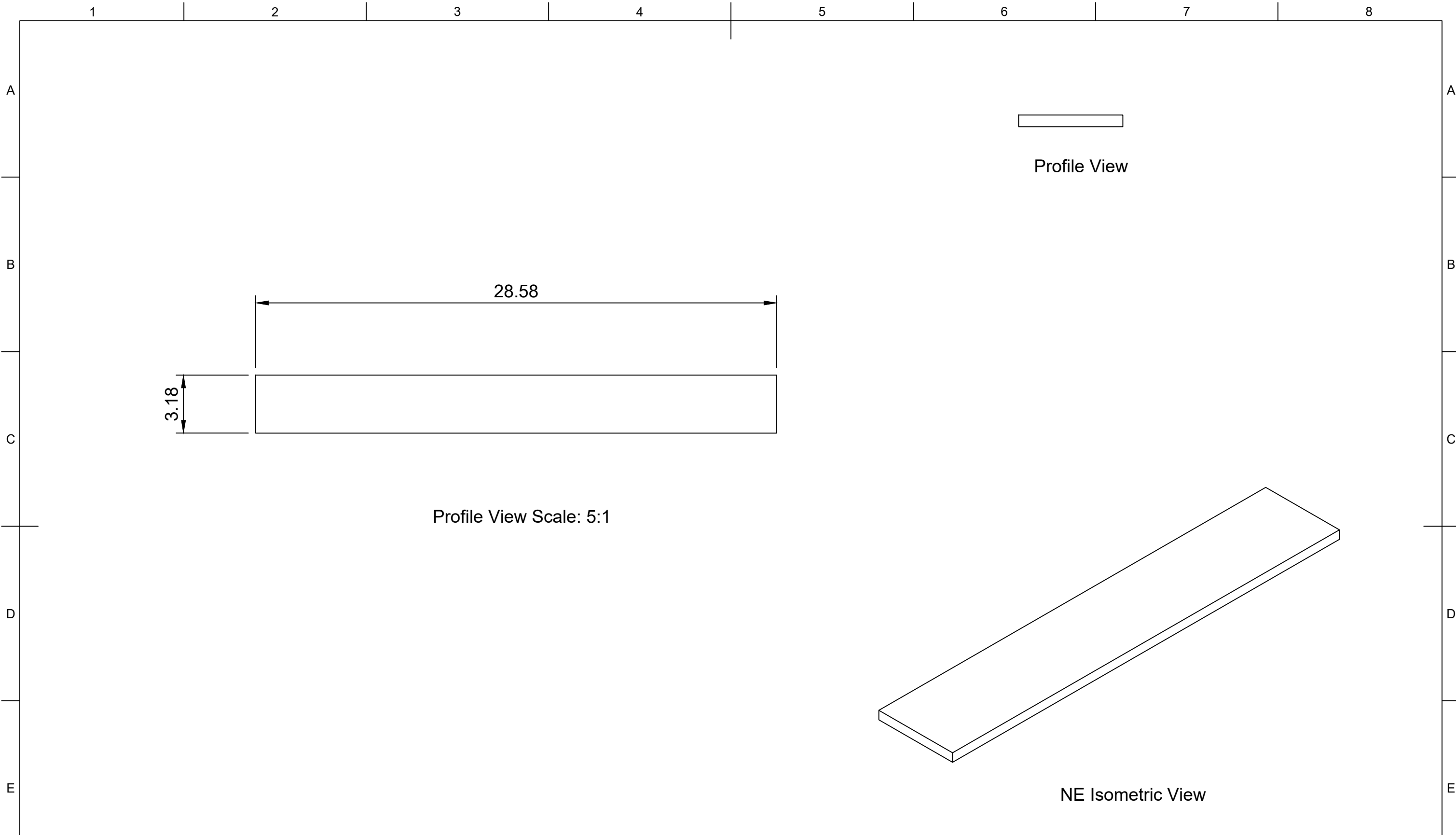

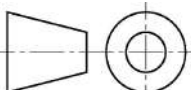
	Part Number				Created By		Cross Sectional Area (mm²)		Nominal Dimension (mm)		Tolerance, ± (mm)	
	203693				David Stirling		91		Greater Than	Less Than or Equal to		
	Description				Date Drawn		Material		0.00	1.50	0.40	
	Rectangle - Solid				30/05/2020		EPDM		1.50	2.50	0.50	
	Revision				Approved By		Hardness (Shore A)		2.50	4.00	0.70	
	A	24/01/2022		Sheet Scale		Date of Approval		70		4.00	6.30	0.80
		1:1		Sheet Size		Colour		Black		6.30	10.00	1.00
		A3		Sheet		Weight (g/m)		115		10.00	16.00	1.30
		1/1		Projection		3rd Agl.				16.00	25.00	1.60
										25.00	40.00	2.00
									40.00	63.00	2.50	
									63.00	100.00	3.20	
									100.00		3.20%	

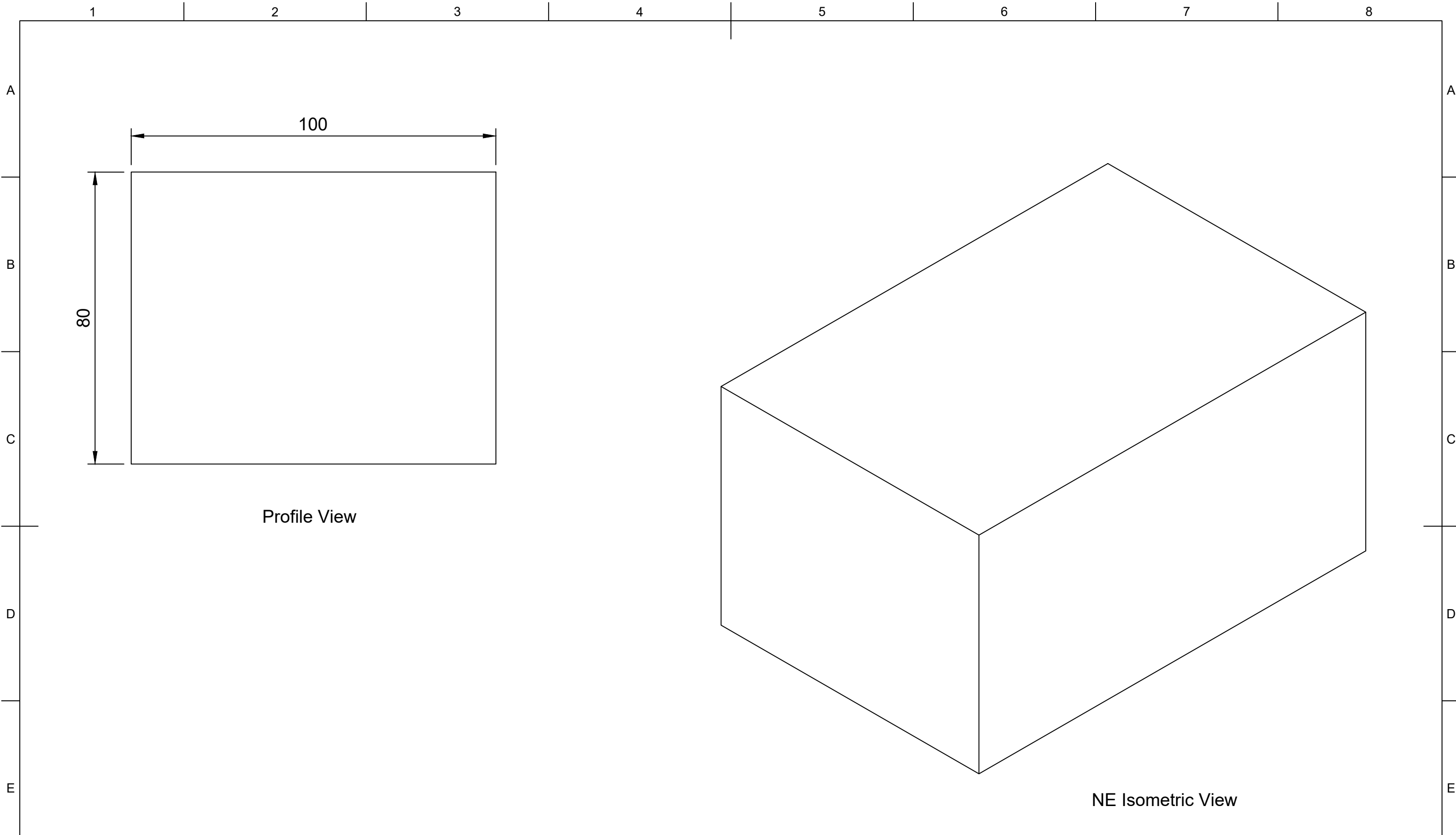

Part Number		205273			Created By		David Stirling		Cross Sectional Area (mm ²)		8000		Nominal Dimension (mm)		Tolerance, ± (mm)
					Date Drawn		24/07/2020		Material		EPDM		Greater Than	Less Than or Equal to	
Description		Rectangle - Solid			Approved By				Hardness (Shore A)		70		1.50	2.50	0.50
					Date of Approval				Colour		Black		2.50	4.00	0.70
Revision	Date of Issue	Sheet Scale	Sheet Size	Sheet	Projection	3rd Agl.		Weight (kg/m)		10.080		4.00	6.30	0.80	
A	31/01/2022	1:1	A3	1/1	6.30							10.00	1.00		
												10.00	16.00	1.30	
												16.00	25.00	1.60	
												25.00	40.00	2.00	
												40.00	63.00	2.50	
												63.00	100.00	3.20	
												100.00		3.20%	

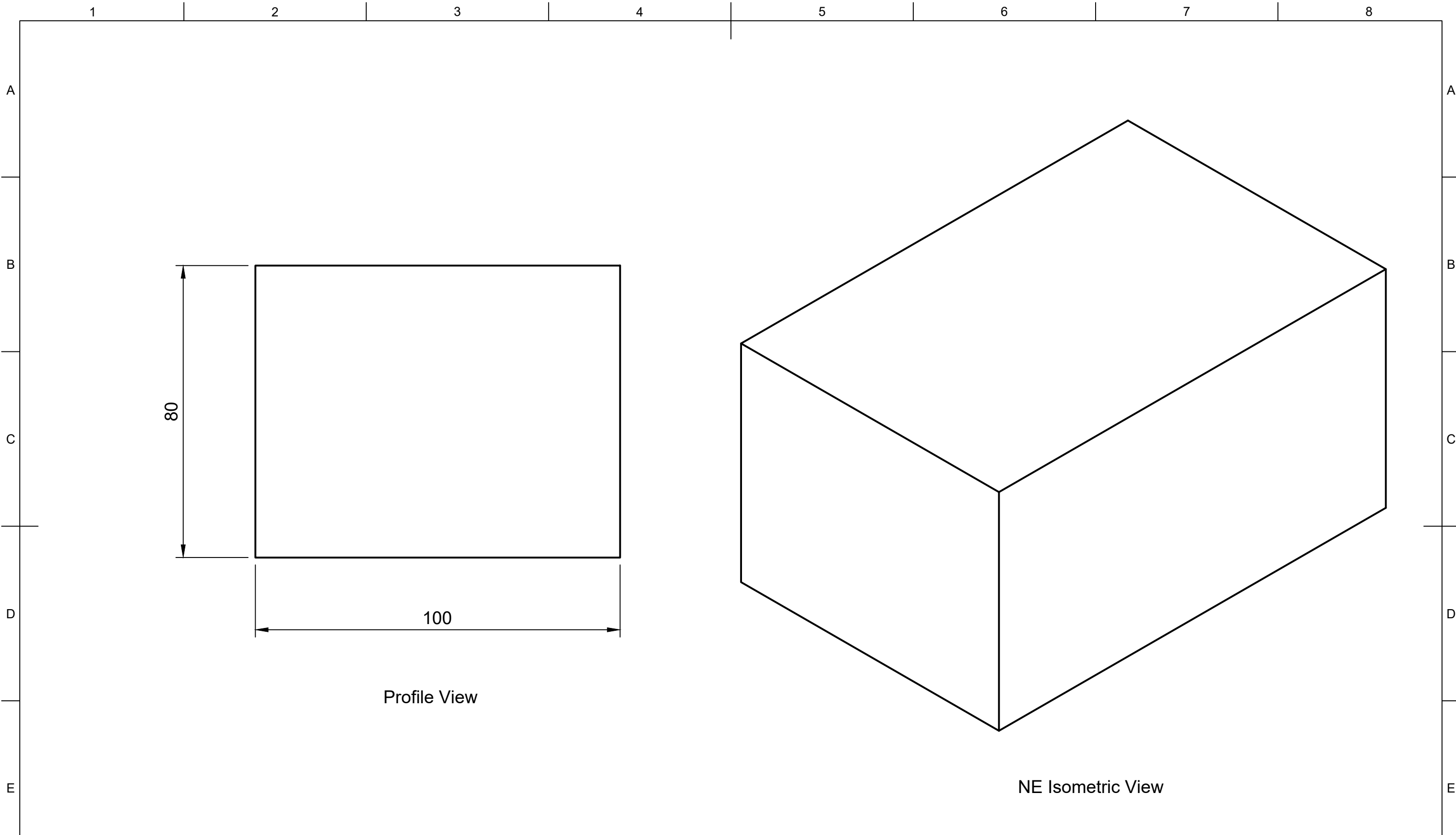

Profile View

NE Isometric View

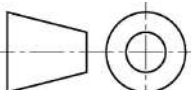
	Part Number				Created By		Cross Sectional Area (mm²)		Nominal Dimension (mm)		Tolerance, ± (mm)
	206430				David Stirling		8000		Greater Than	Less Than or Equal to	
	Description				Date Drawn		Material		0.00	1.50	0.40
					31/01/2022		Neoprene		1.50	2.50	0.50
	Rectangle - Solid				Approved By		Hardness (Shore A)		2.50	4.00	0.70
					Date of Approval		70		4.00	6.30	0.80
							Colour		6.30	10.00	1.00
	Revision		Date of Issue		Projection		Weight (kg/m)		10.00	16.00	1.30
	A	31/01/2022		3rd Agl. 		12.160		16.00	25.00	1.60	
	Sheet Scale		Sheet Size		Sheet				25.00	40.00	2.00
1:1		A3		1/1				40.00	63.00	2.50	
								63.00	100.00	3.20	
								100.00		3.20%	

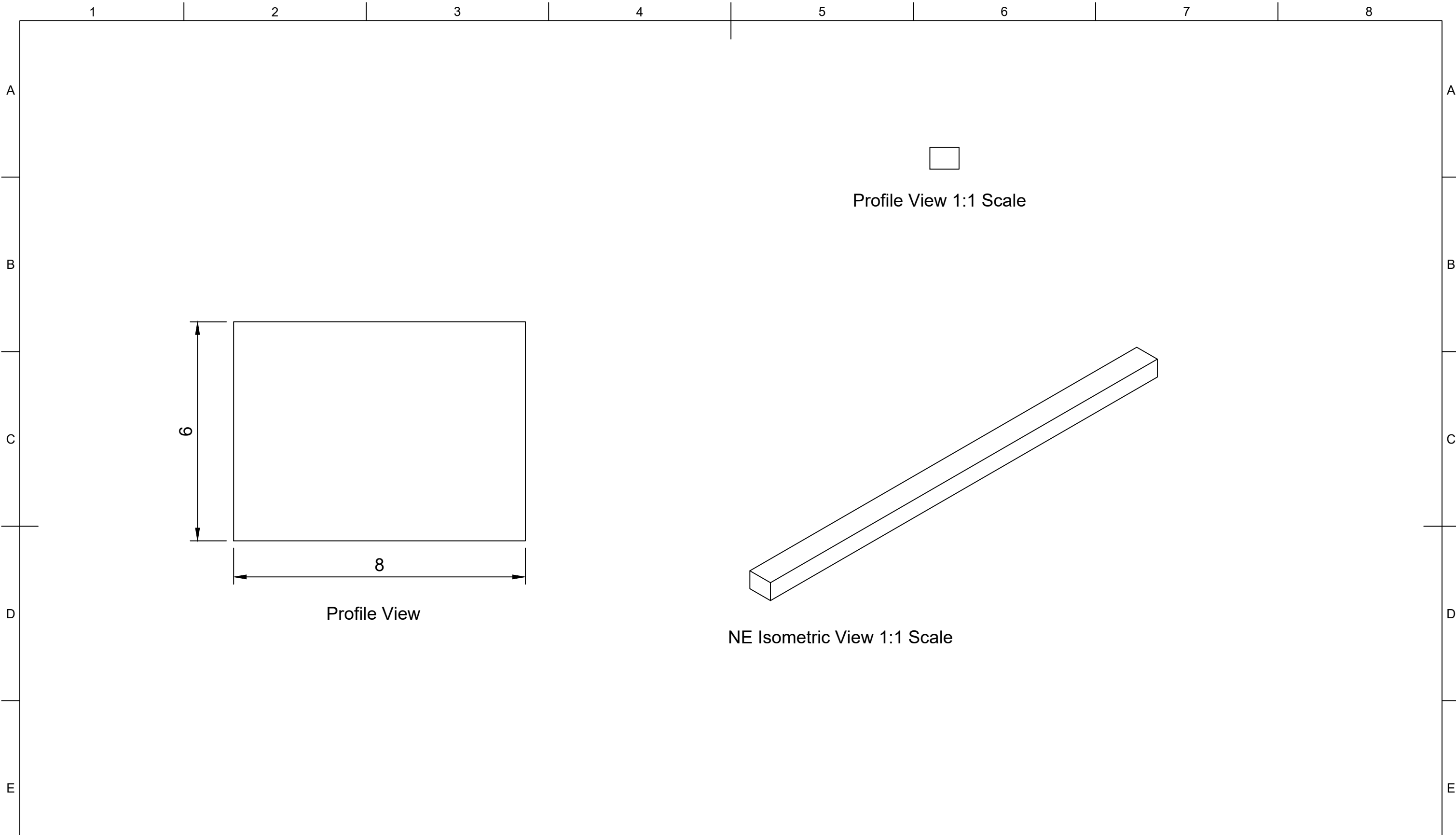

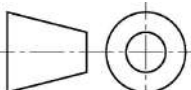
	Part Number				Created By		Cross Sectional Area (mm²)		Nominal Dimension (mm)		Tolerance, ± (mm)	
	206846				David Stirling		48		Greater Than	Less Than or Equal to		
	Description				Date Drawn		Material		0.00	1.50	0.40	
	Rectangle - Solid				06/08/2020		EPDM		1.50	2.50	0.50	
	Revision				Approved By		Hardness (Shore A)		2.50	4.00	0.70	
	A	31/01/2022		10:1		Date of Approval		70		4.00	6.30	0.80
	Date of Issue		Sheet Scale		Sheet Size		Colour		6.30	10.00	1.00	
	10:1		A3		1/1		Black		10.00	16.00	1.30	
	Projection		Sheet		Weight (g/m)		3rd Agl.		16.00	25.00	1.60	
	3rd Agl.		1/1		60				25.00	40.00	2.00	
								40.00	63.00	2.50		
								63.00	100.00	3.20		
								100.00		3.20%		

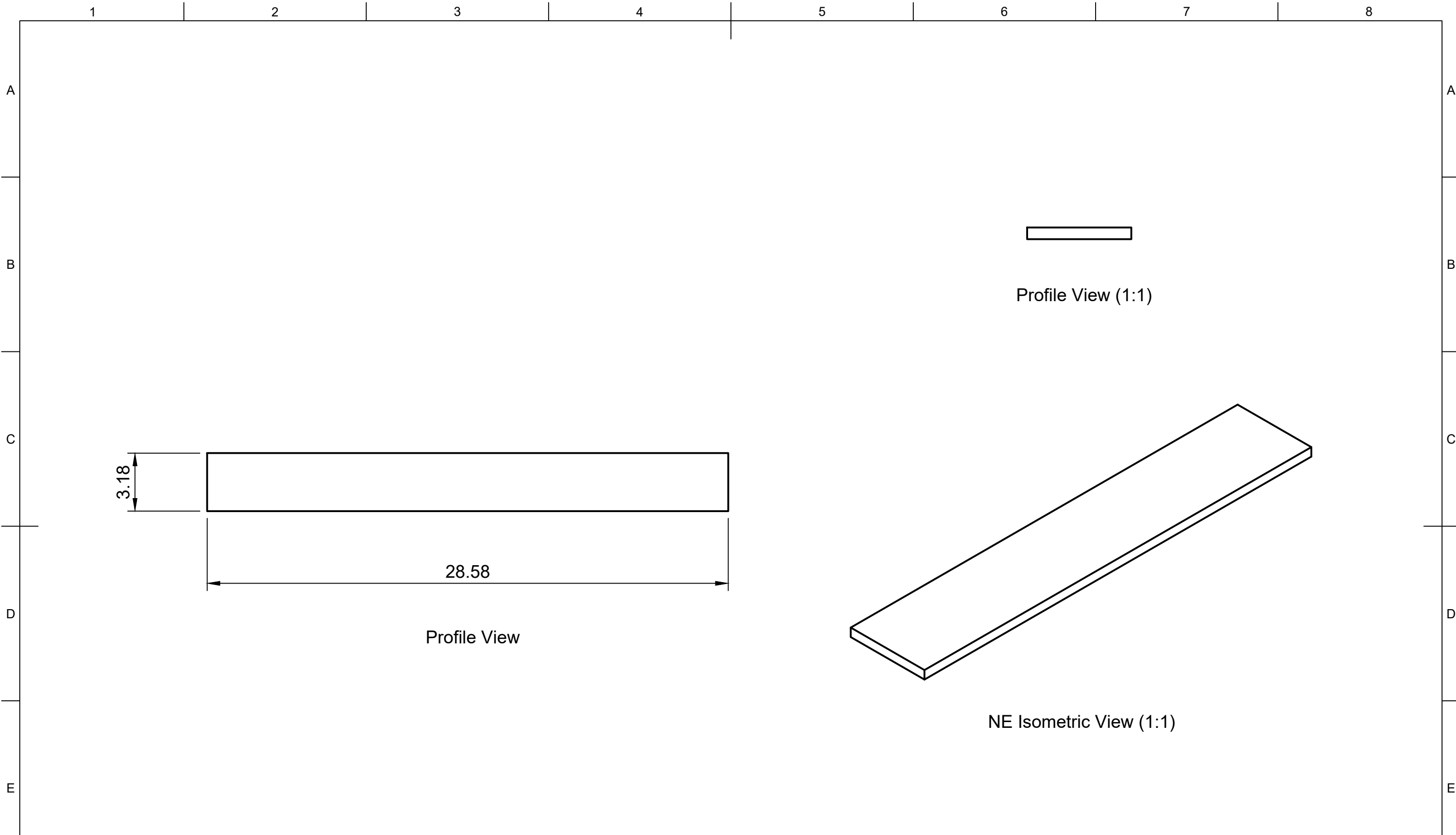

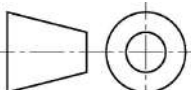
	Part Number				Created By		Cross Sectional Area (mm²)		Nominal Dimension (mm)		Tolerance, ± (mm)	
	207891				David Stirling		91		Greater Than	Less Than or Equal to		
	Description				Date Drawn		Material		0.00		0.40	
	Rectangle - Solid				24/01/2022		Neoprene		1.50		0.50	
	Revision				Approved By		Hardness (Shore A)		2.50		0.70	
	A	24/01/2022		5:1		Date of Approval		70		4.00		0.80
	Date of Issue		Sheet Scale		Sheet Size		Colour		6.30		1.00	
	24/01/2022		5:1		A3		Black		10.00		1.30	
	Sheet		Projection		Weight (g/m)		138		16.00		1.60	
	1/1		3rd Agl. 						25.00		2.00	
								40.00		2.50		
								63.00		3.20		
								100.00		3.20%		

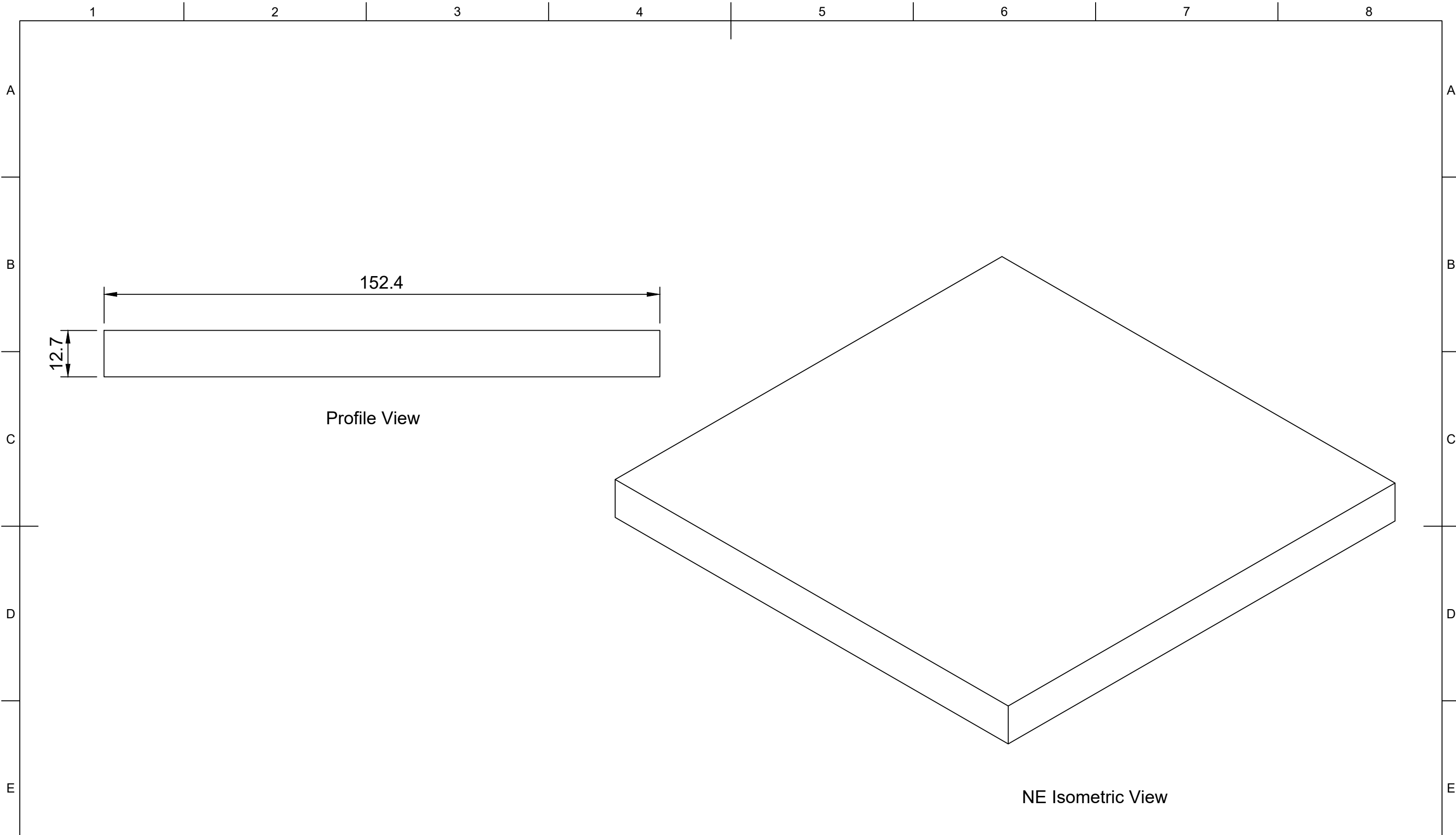

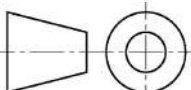
	Part Number				Created By		Cross Sectional Area (mm²)		Nominal Dimension (mm)		Tolerance, ± (mm)
	208227				David Stirling		1935		Greater Than	Less Than or Equal to	
	Description				Date Drawn		Material		0.00	1.50	0.40
					30/05/2020		EPDM		1.50	2.50	0.50
	Rectangle - Solid				Approved By		Hardness (Shore A)		2.50	4.00	0.70
					Date of Approval		70		4.00	6.30	0.80
							Black		6.30	10.00	1.00
	Revision	Date of Issue	Sheet Scale	Sheet Size	Sheet	Projection	Weight (kg/m)		10.00	16.00	1.30
	A	24/01/2022	1:1	A3	1/1	3rd Agl. 	2.438		16.00	25.00	1.60
									25.00	40.00	2.00
								40.00	63.00	2.50	
								63.00	100.00	3.20	
								100.00		3.20%	

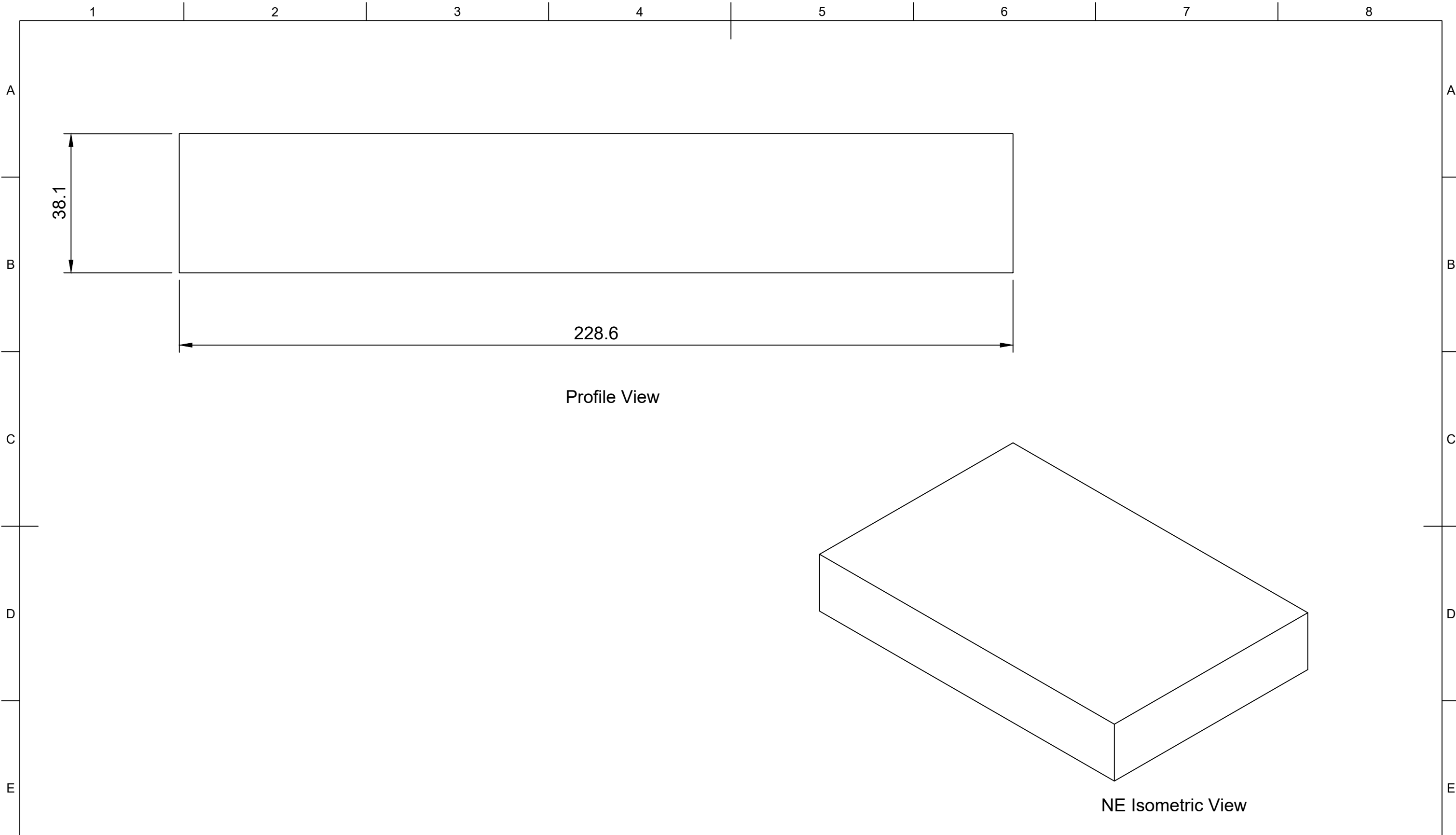

Profile View

NE Isometric View

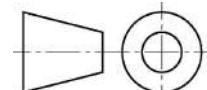
	Part Number				Created By		Cross Sectional Area (mm²)		Nominal Dimension (mm)		Tolerance, ± (mm)
	209587				David Stirling		8710		Greater Than	Less Than or Equal to	
					Date Drawn		Material		0.00	1.50	0.40
					10/04/2020		EPDM		1.50	2.50	0.50
	Description				Approved By		Hardness (Shore A)		2.50	4.00	0.70
	Rectangle - Solid						70		4.00	6.30	0.80
					Date of Approval		Colour		6.30	10.00	1.00
							Black		10.00	16.00	1.30
							Weight (kg/m)		16.00	25.00	1.60
	Revision	Date of Issue	Sheet Scale	Sheet Size	Sheet	Projection			25.00	40.00	2.00
A	13/01/2022	1:1	A3	1/1	3rd Agl. 	10.975		40.00	63.00	2.50	
									63.00	100.00	3.20
									100.00		3.20%

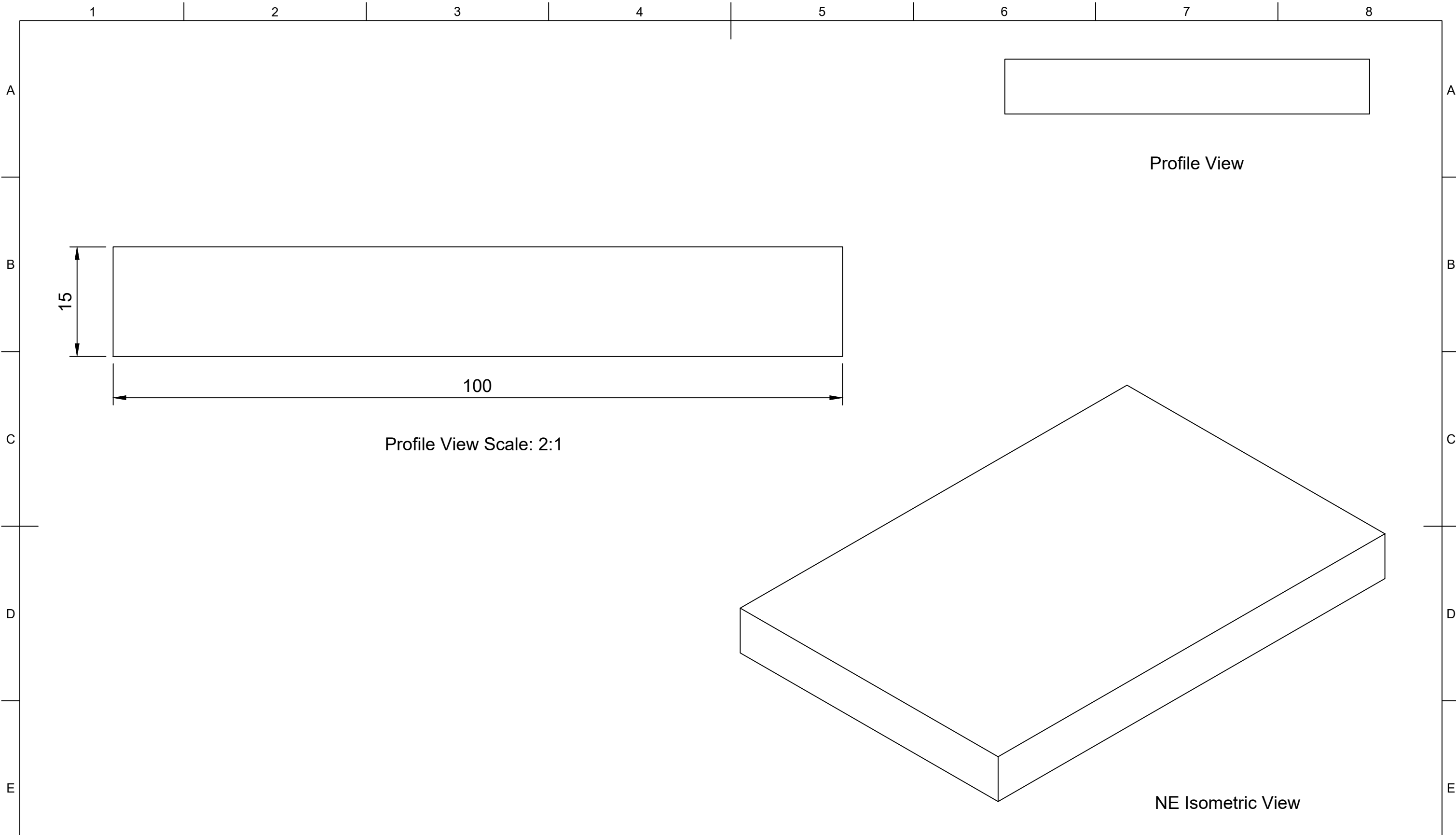

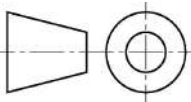
	Part Number				Created By		Cross Sectional Area (mm²)		Nominal Dimension (mm)		Tolerance, ± (mm)
	202425				David Stirling		1500		Greater Than	Less Than or Equal to	
					Date Drawn		Material		0.00	1.50	0.40
					24/07/2020		EPDM		1.50	2.50	0.50
	Description				Approved By		Hardness (Shore A)		2.50	4.00	0.70
	Rectangle - Solid						70		4.00	6.30	0.80
					Date of Approval		Colour		6.30	10.00	1.00
							Black		10.00	16.00	1.30
									16.00	25.00	1.60
									25.00	40.00	2.00
Revision	Date of Issue	Sheet Scale	Sheet Size	Sheet	Projection	Weight (kg/m)		40.00	63.00	2.50	
A	31/01/2022	1:1	A3	1/1	3rd Agl. 	1.890		63.00	100.00	3.20	
								100.00		3.20%	

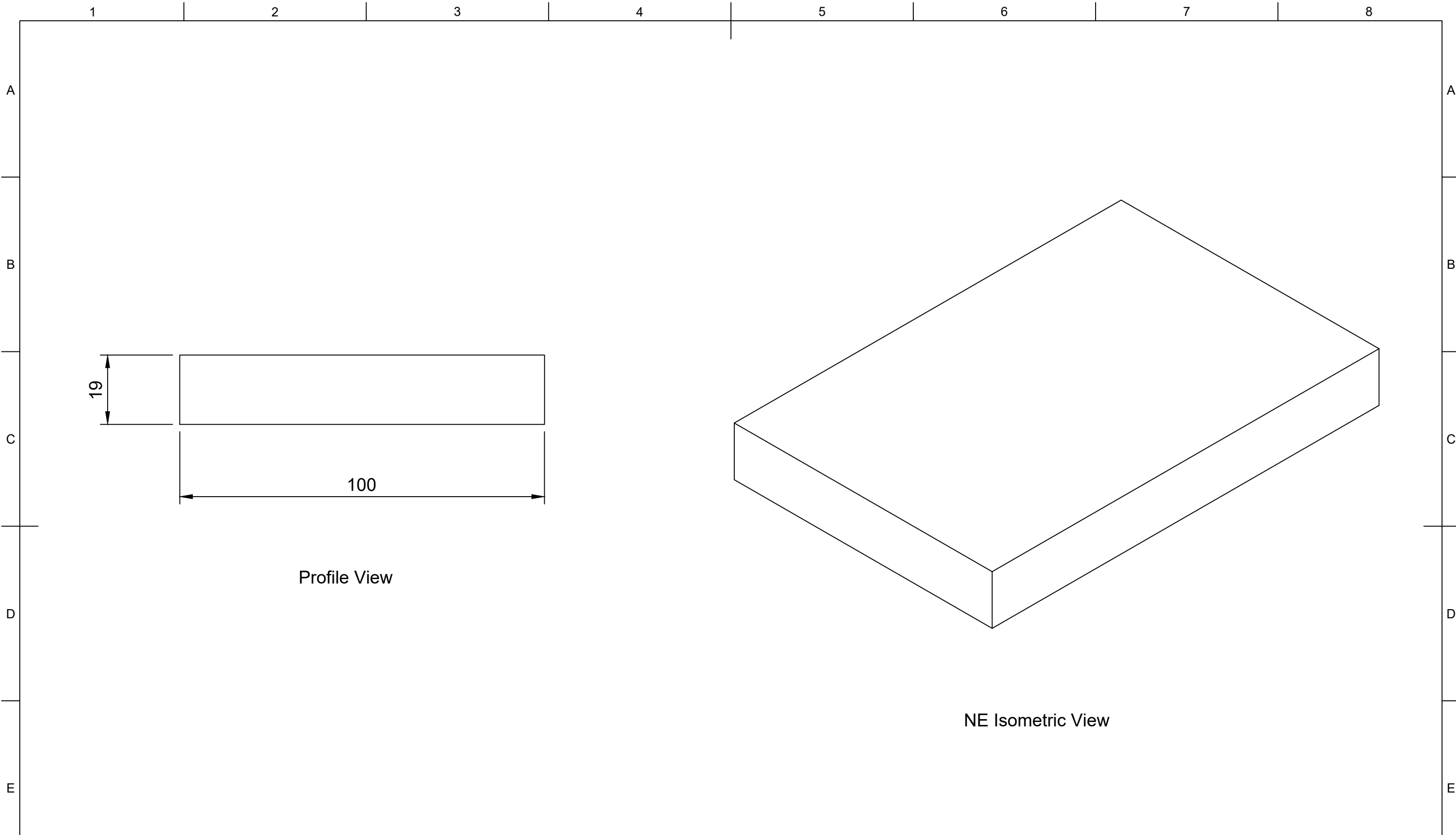

Profile View

NE Isometric View

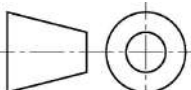
	Part Number				Created By		Cross Sectional Area (mm²)		Nominal Dimension (mm)		Tolerance, ± (mm)
	205219				David Stirling		1900		Greater Than	Less Than or Equal to	
	Description				Date Drawn		Material		0.00	1.50	0.40
					04/11/2020		EPDM		1.50	2.50	0.50
	Rectangle - Solid				Approved By		Hardness (Shore A)		2.50	4.00	0.70
					Date of Approval		70		4.00	6.30	0.80
							Colour		6.30	10.00	1.00
					Black		10.00	16.00	1.30		
	Revision	Date of Issue	Sheet Scale	Sheet Size	Sheet	Projection	Weight (kg/m)		16.00	25.00	1.60
	A	31/01/22	1:1	A3	1/1	3rd Agl. 	2.394		25.00	40.00	2.00
								40.00	63.00	2.50	
								63.00	100.00	3.20	
								100.00		3.20%	

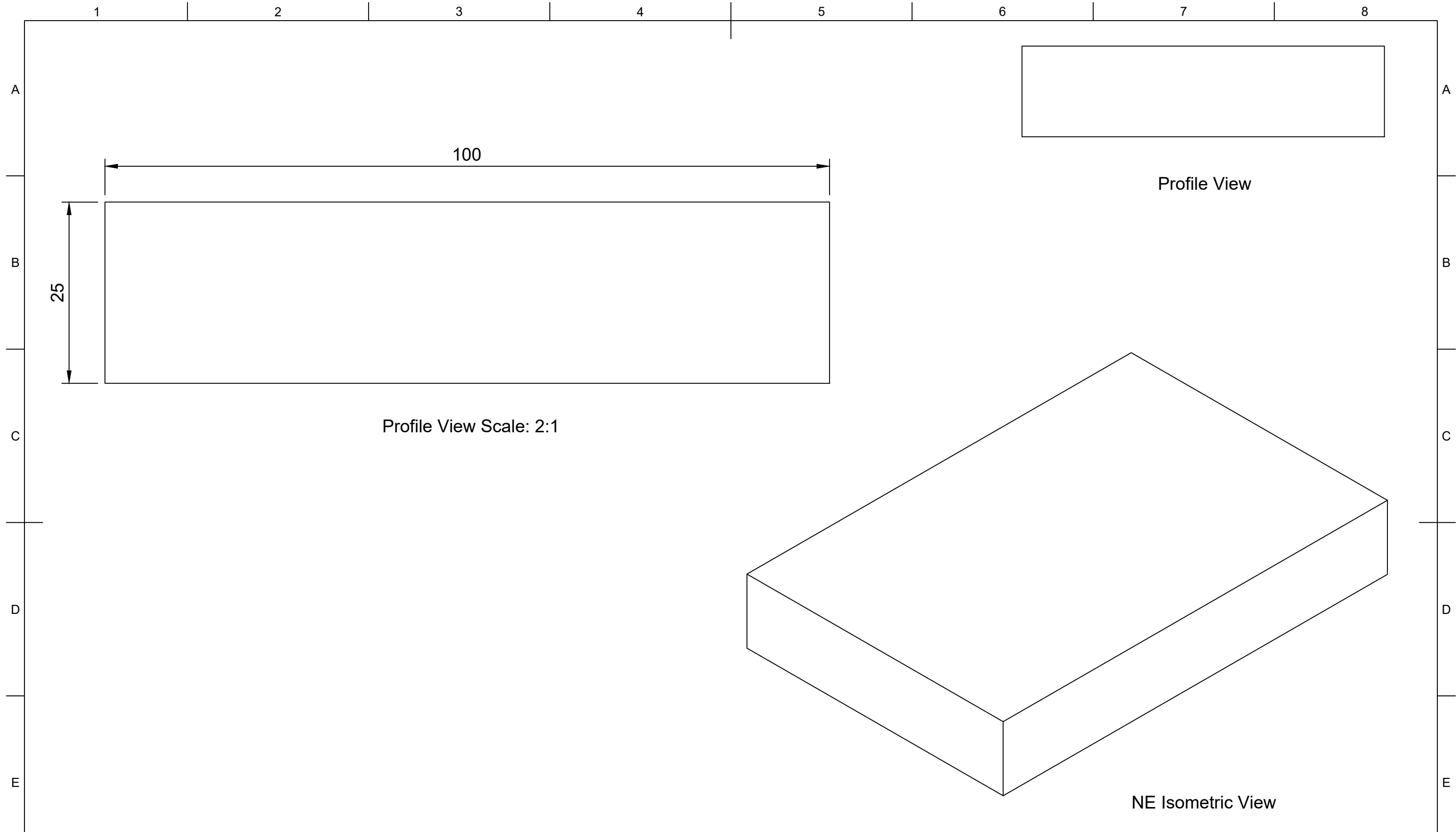

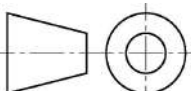
	Part Number				Created By		Cross Sectional Area (mm²)		Nominal Dimension (mm)		Tolerance, ± (mm)	
	200339				Isaac Erskine		2500		Greater Than	Less Than or Equal to		
					Date Drawn		Material		0.00	1.50	0.40	
					24/07/2020		EPDM		1.50	2.50	0.50	
	Description				Approved By		Hardness (Shore A)		2.50	4.00	0.70	
	Rectangle - Solid						70		4.00	6.30	0.80	
					Date of Approval		Colour		6.30	10.00	1.00	
							Black		10.00	16.00	1.30	
					Projection		Weight (kg/m)		16.00	25.00	1.60	
					3rd Agl. 		3.150		25.00	40.00	2.00	
Revision	Date of Issue	Sheet Scale	Sheet Size	Sheet					40.00	63.00	2.50	
A	14/02/2022	1:1	A3	1/1					63.00	100.00	3.20	
										100.00		3.20%

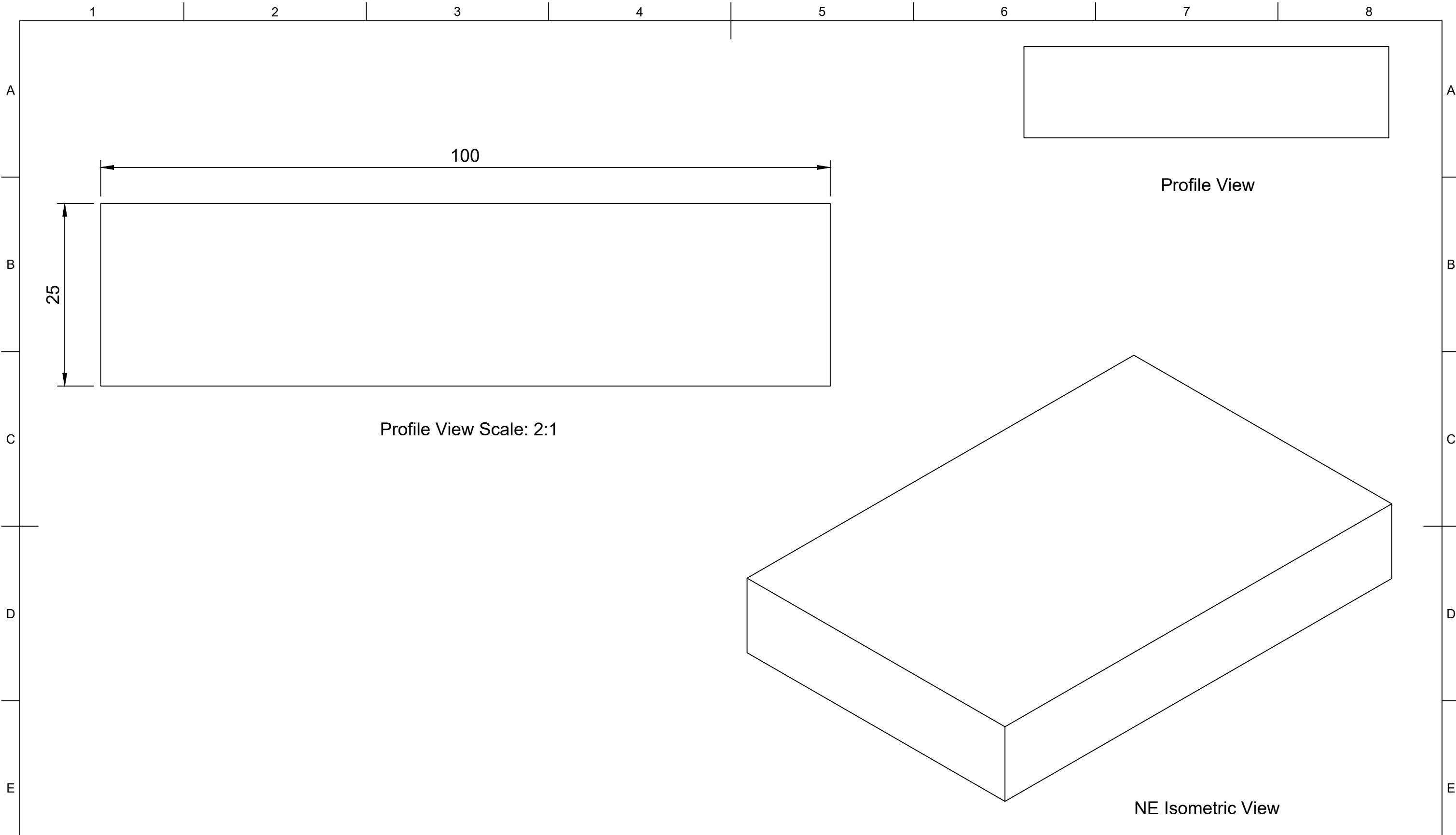

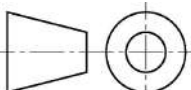
	Part Number				Created By		Cross Sectional Area (mm²)		Nominal Dimension (mm)		Tolerance, ± (mm)	
	206256				Isaac Erskine		2500		Greater Than	Less Than or Equal to		
	Description				Date Drawn		Material		0.00	1.50	0.40	
	Rectangle - Solid				24/07/2020		Neoprene		1.50	2.50	0.50	
	Revision				Approved By		Hardness (Shore A)		2.50	4.00	0.70	
	A	14/02/2022		Sheet Scale		Date of Approval		70		4.00	6.30	0.80
		1:1		Sheet Size		Colour		Black		6.30	10.00	1.00
		A3		Sheet		Weight (kg/m)		3.800		10.00	16.00	1.30
		1/1		Projection		3rd Agl.				16.00	25.00	1.60
										25.00	40.00	2.00
									40.00	63.00	2.50	
									63.00	100.00	3.20	
									100.00		3.20%	

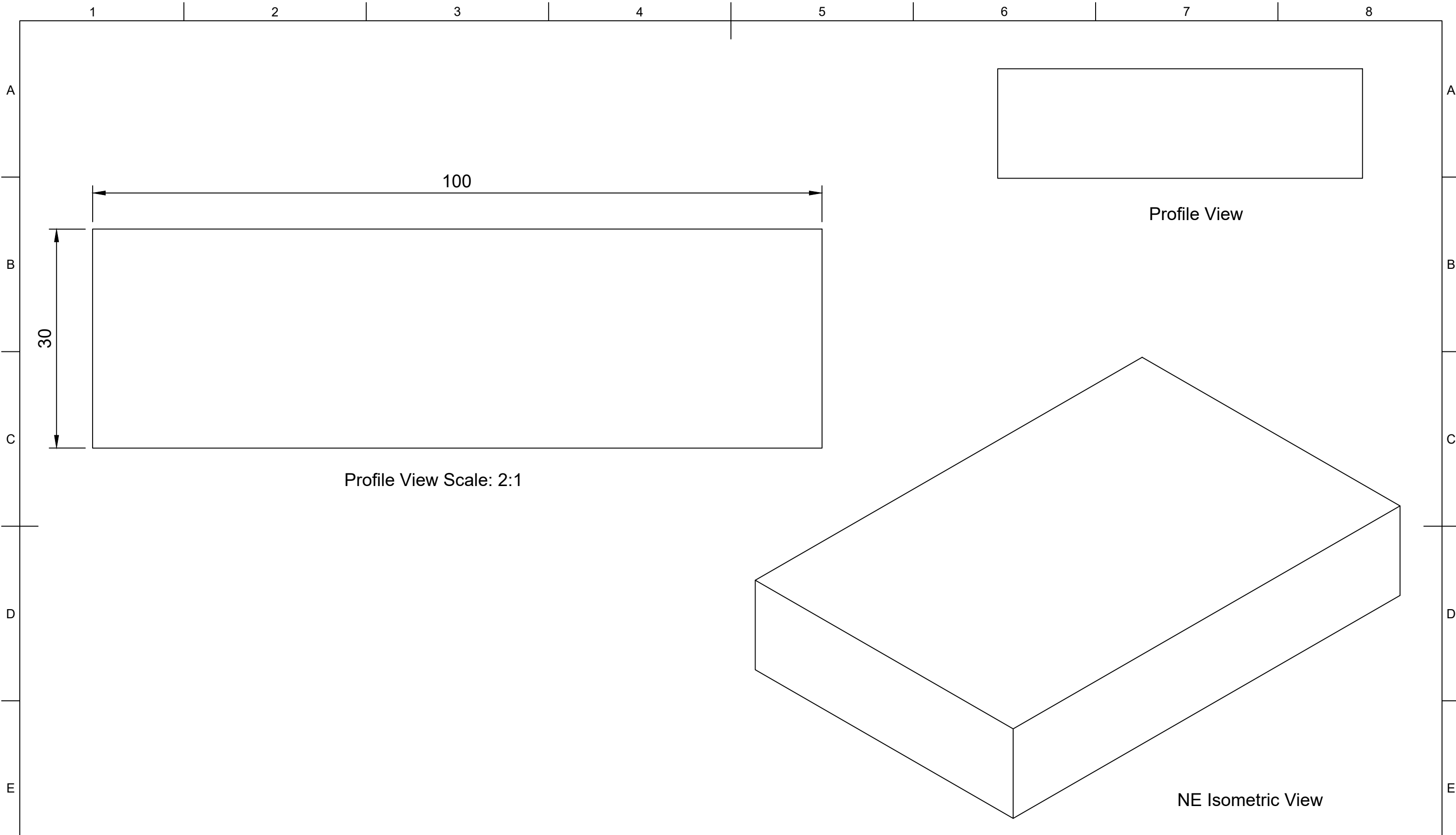

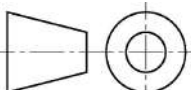
	Part Number				Created By		Cross Sectional Area (mm²)		Nominal Dimension (mm)		Tolerance, ± (mm)
	209813				Isaac Erskine		3000		Greater Than	Less Than or Equal to	
	Description				Date Drawn		Material		0.00		0.40
	Rectangle - Solid				24/07/2020		EPDM		1.50		0.50
	Revision				Approved By		Hardness (Shore A)		2.50		0.70
	A				Date of Approval		70		4.00		0.80
	Date of Issue				Projection		Colour		6.30		1.00
	14/02/2022				3rd Agl. 		Black		10.00		1.30
	Sheet Scale				Weight (kg/m)		3.780		16.00		1.60
	1:1								25.00		2.00
Sheet Size								40.00		2.50	
A3								63.00		3.20	
Sheet								100.00		3.20%	
1/1											

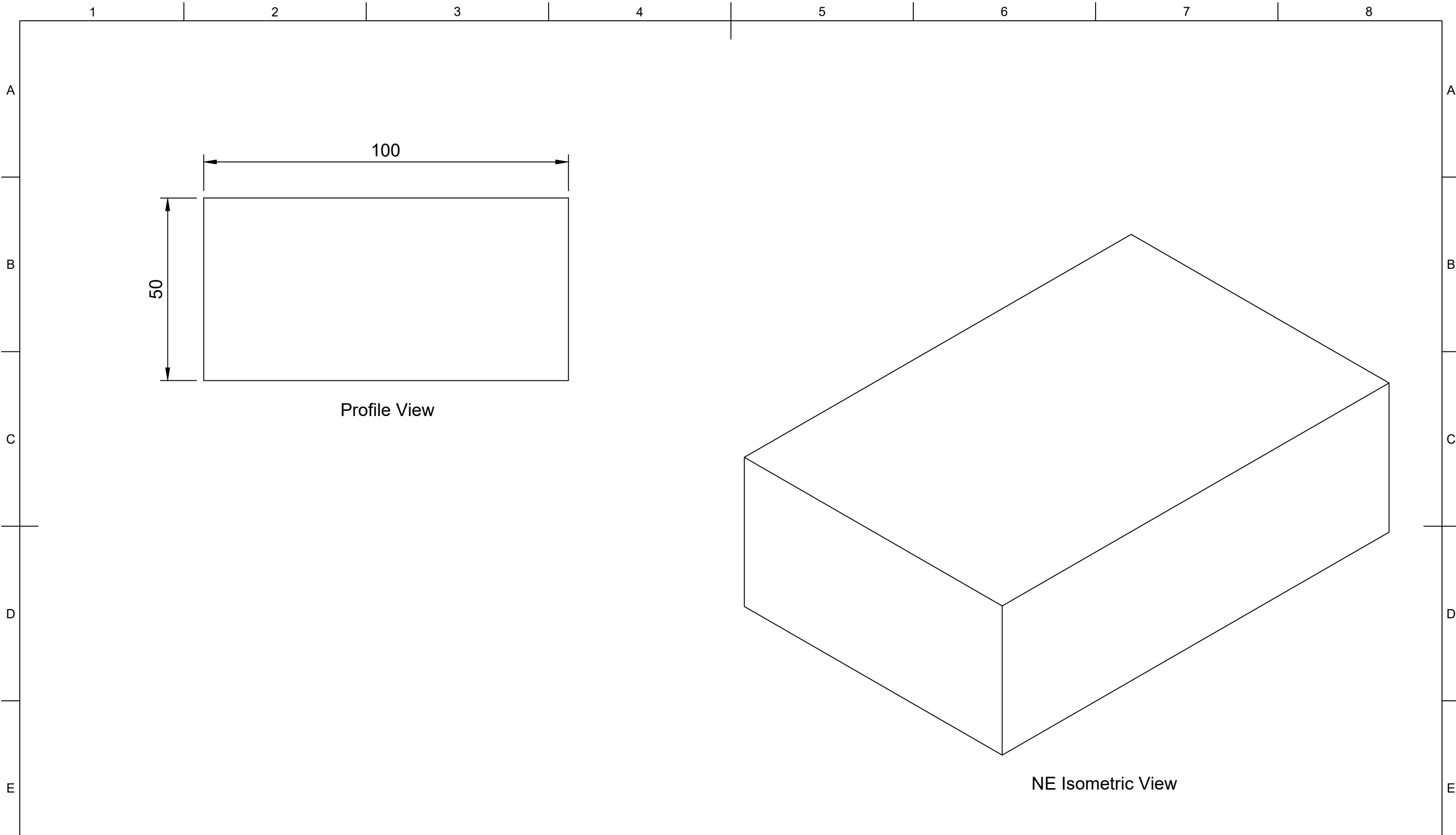

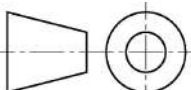
	Part Number				Created By		Cross Sectional Area (mm²)		Nominal Dimension (mm)		Tolerance, ± (mm)
	201737				Isaac Erskine		5000		Greater Than	Less Than or Equal to	
	Description				Date Drawn		Material		0.00	1.50	0.40
					24/07/2020		EPDM		1.50	2.50	0.50
	Rectangle - Solid				Approved By		Hardness (Shore A)		2.50	4.00	0.70
					Date of Approval		70		4.00	6.30	0.80
							Black		6.30	10.00	1.00
	Revision	Date of Issue	Sheet Scale	Sheet Size	Sheet	Projection	Weight (kg/m)		10.00	16.00	1.30
	A	14/02/2022	1:1	A3	1/1	3rd Agl. 	6.300		16.00	25.00	1.60
									25.00	40.00	2.00
								40.00	63.00	2.50	
								63.00	100.00	3.20	
								100.00		3.20%	

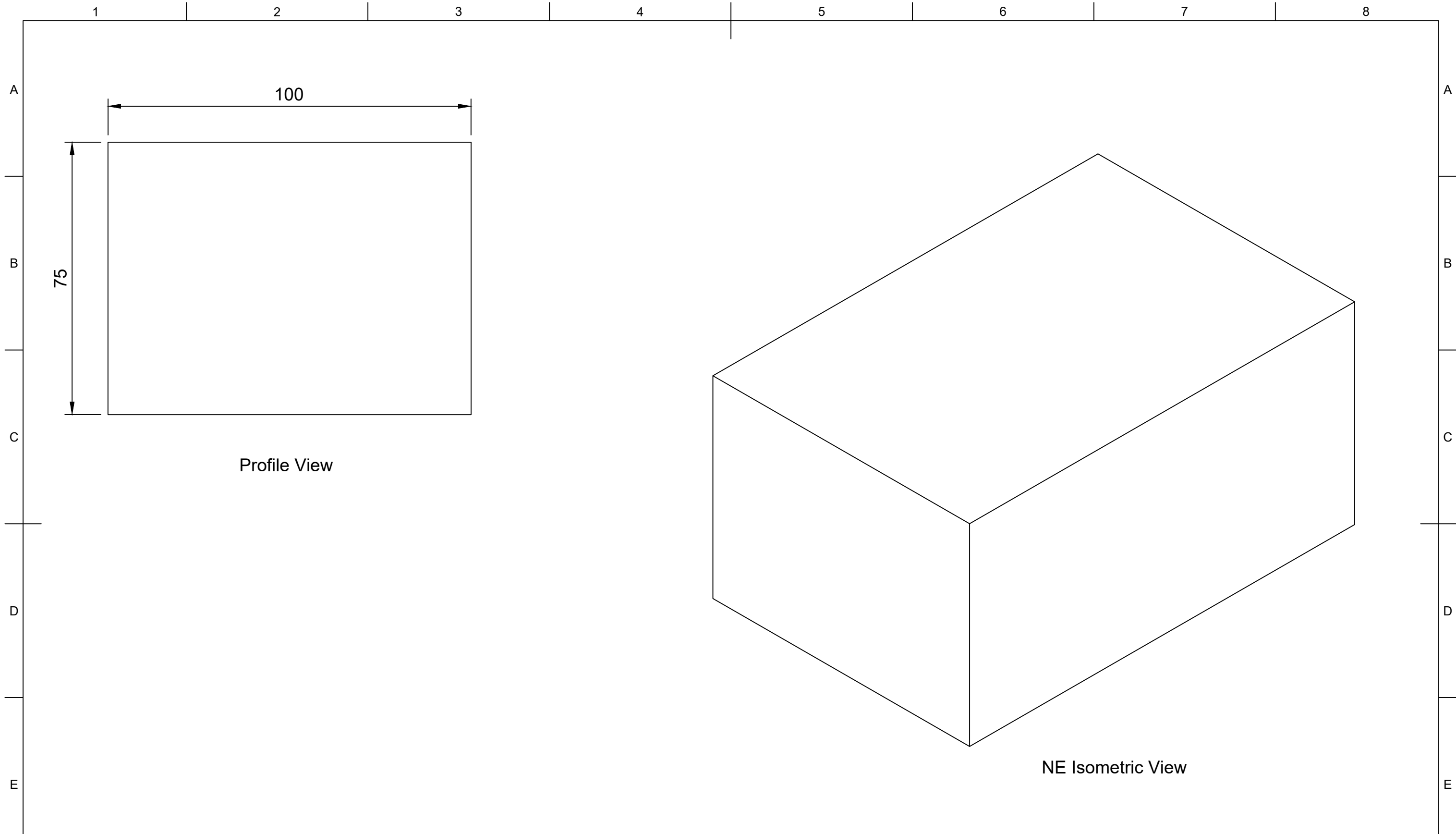

Profile View

NE Isometric View

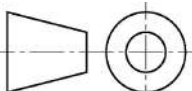
	Part Number				Created By		Cross Sectional Area (mm²)		Nominal Dimension (mm)		Tolerance, ± (mm)
	209436				Isaac Erskine		7500		Greater Than	Less Than or Equal to	
	Description				Date Drawn		Material		0.00	1.50	0.40
					24/07/2020		Nitrile		1.50	2.50	0.50
	Rectangle - Solid				Approved By		Hardness (Shore A)		2.50	4.00	0.70
							70		4.00	6.30	0.80
					Date of Approval		Colour		6.30	10.00	1.00
							Black		10.00	16.00	1.30
					Projection		Weight (kg/m)		16.00	25.00	1.60
					3rd Agl. 				25.00	40.00	2.00
								40.00	63.00	2.50	
								63.00	100.00	3.20	
								100.00		3.20%	
Revision	Date of Issue	Sheet Scale	Sheet Size	Sheet							
A	14/02/2022	1:1	A3	1/1							

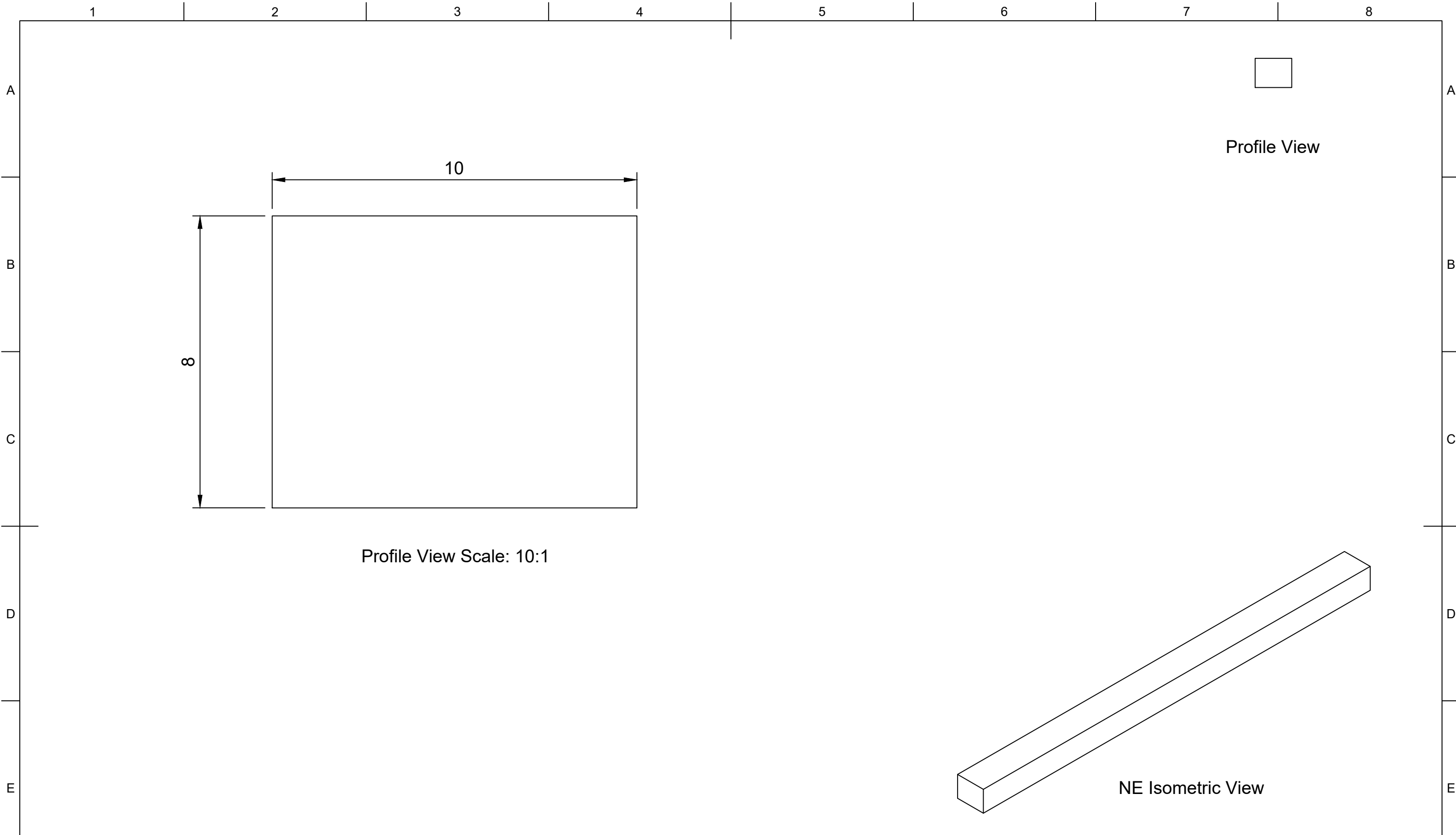

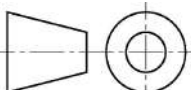
	Part Number				Created By		Cross Sectional Area (mm²)		Nominal Dimension (mm)		Tolerance, ± (mm)			
	202841				Isaac Erskine		80		Greater Than	Less Than or Equal to				
	Description				Date Drawn		Material		0.00	1.50	0.40			
	Rectangle - Solid				24/07/2020		EPDM		1.50	2.50	0.50			
	Revision				Approved By		Hardness (Shore A)		2.50	4.00	0.70			
	A	Date of Issue		Sheet Scale		Sheet Size		Sheet		Date of Approval		Colour		
		14/02/2022		1:1		A3		1/1		3rd Agl. 		Black		
										Weight (g/m)		10.00	25.00	1.60
										101		25.00	40.00	2.00
												40.00	63.00	2.50
											63.00	100.00	3.20	
											100.00		3.20%	

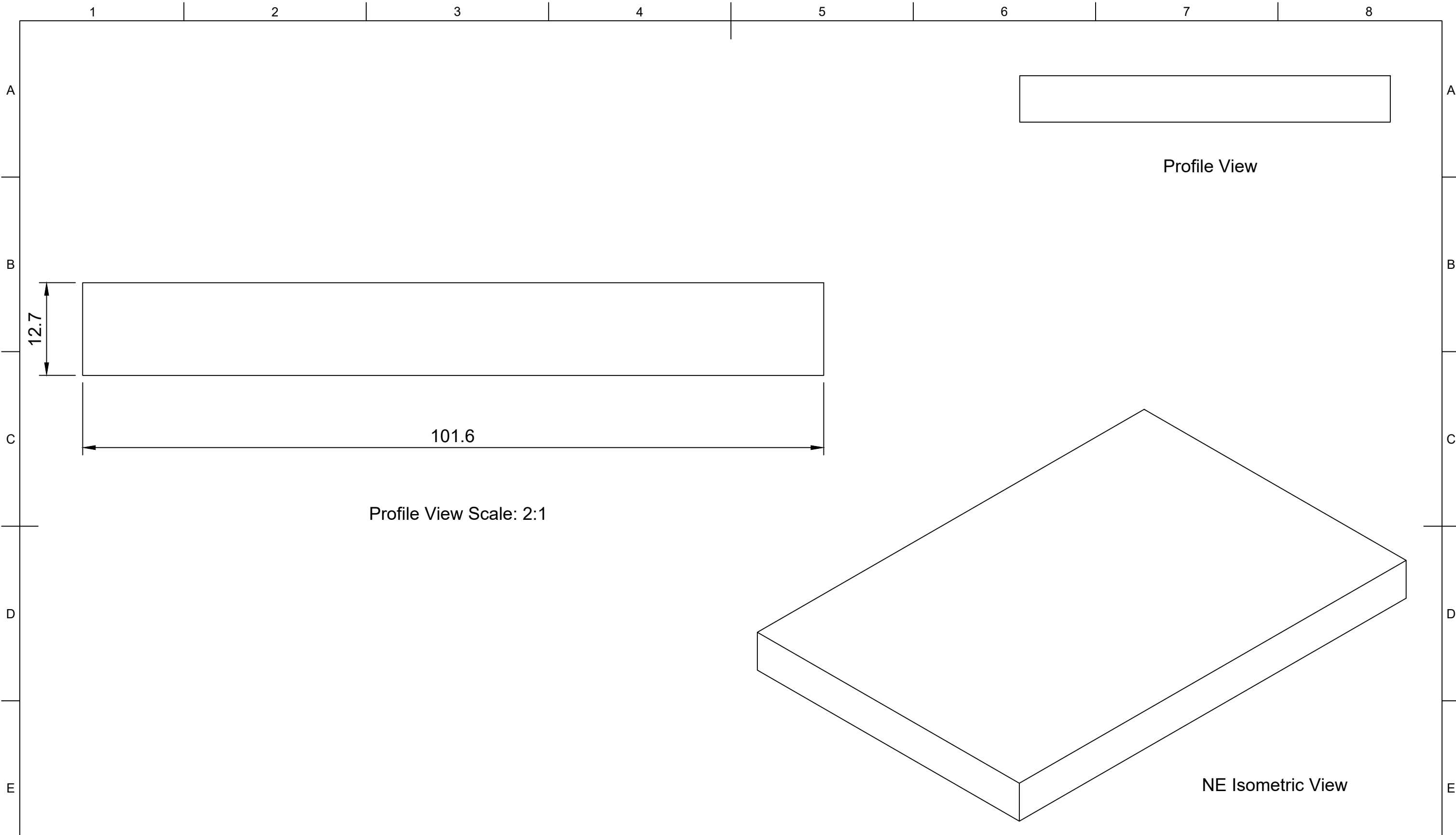

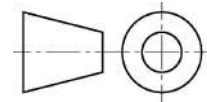
	Part Number				Created By		Cross Sectional Area (mm²)		Nominal Dimension (mm)		Tolerance, ± (mm)
	203013				Isaac Erskine		1290		Greater Than	Less Than or Equal to	
					Date Drawn		Material		0.00	1.50	0.40
					25/07/2020		EPDM		1.50	2.50	0.50
	Description				Approved By		Hardness (Shore A)		2.50	4.00	0.70
	Rectangle - Solid						70		4.00	6.30	0.80
					Date of Approval		Colour		6.30	10.00	1.00
							Black		10.00	16.00	1.30
							Weight (kg/m)		16.00	25.00	1.60
							1.625		25.00	40.00	2.00
Revision	Date of Issue	Sheet Scale	Sheet Size	Sheet	Projection			40.00	63.00	2.50	
A	14/02/2022	1:1	A3	1/1	3rd Agl.			63.00	100.00	3.20	
								100.00		3.20%	

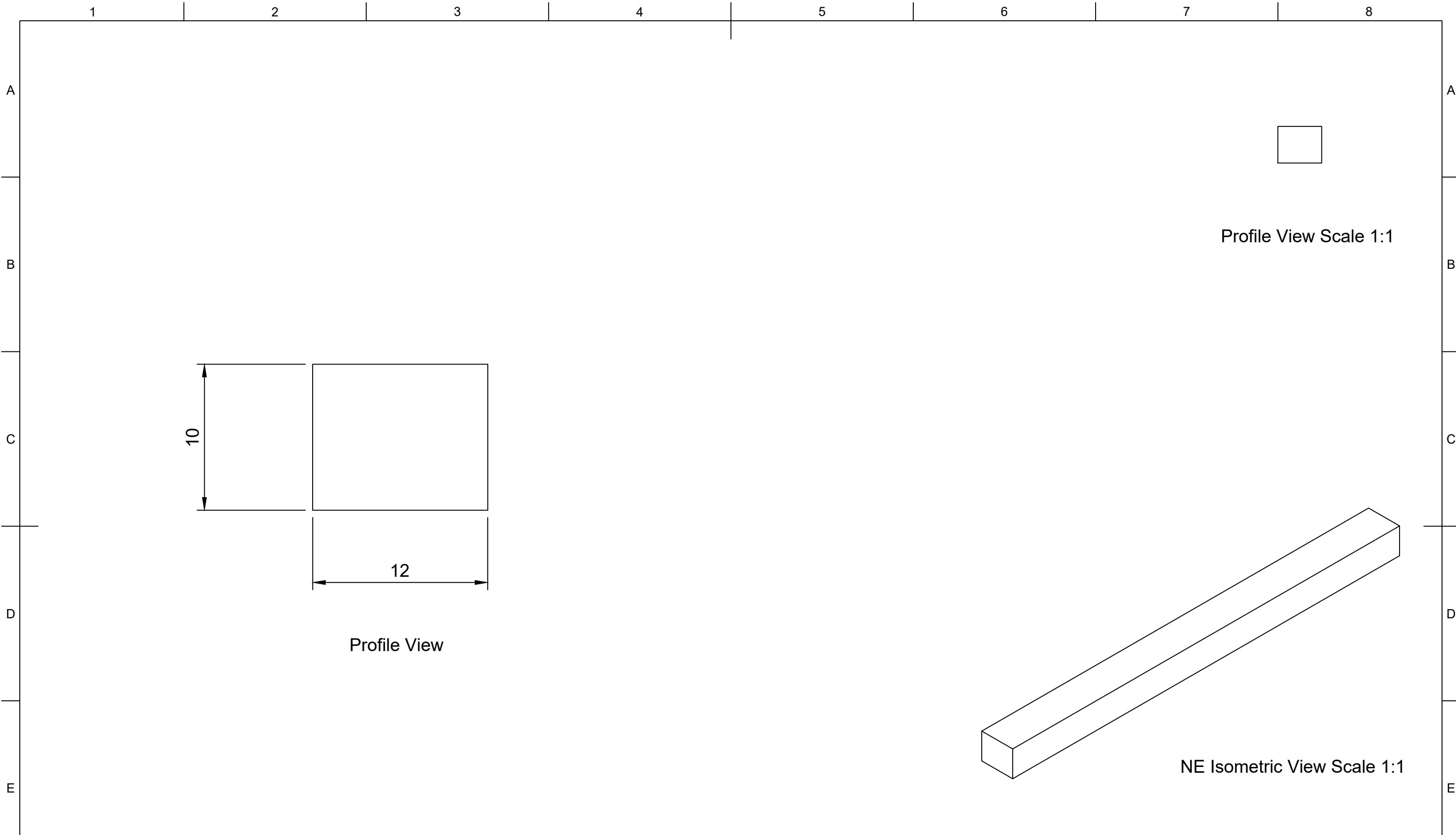

	Part Number				Created By		Cross Sectional Area (mm²)		Nominal Dimension (mm)		Tolerance, ± (mm)
	204116				David Stirling		120		Greater Than	Less Than or Equal to	
					Date Drawn		Material		0.00	1.50	0.40
					04/11/2020		EPDM		1.50	2.50	0.50
	Description				Approved By		Hardness (Shore A)		2.50	4.00	0.70
	Rectangle - Solid				David Stirling		70		4.00	6.30	0.80
					Date of Approval		Colour		6.30	10.00	1.00
					04/11/2020		Black		10.00	16.00	1.30
									16.00	25.00	1.60
									25.00	40.00	2.00
Revision	Date of Issue	Sheet Scale	Sheet Size	Sheet	Projection	Weight (g/m)		40.00	63.00	2.50	
A	04/11/2020	4:1	A3	1/1	3rd Agl.	151		63.00	100.00	3.20	
								100.00	---	3.20%	

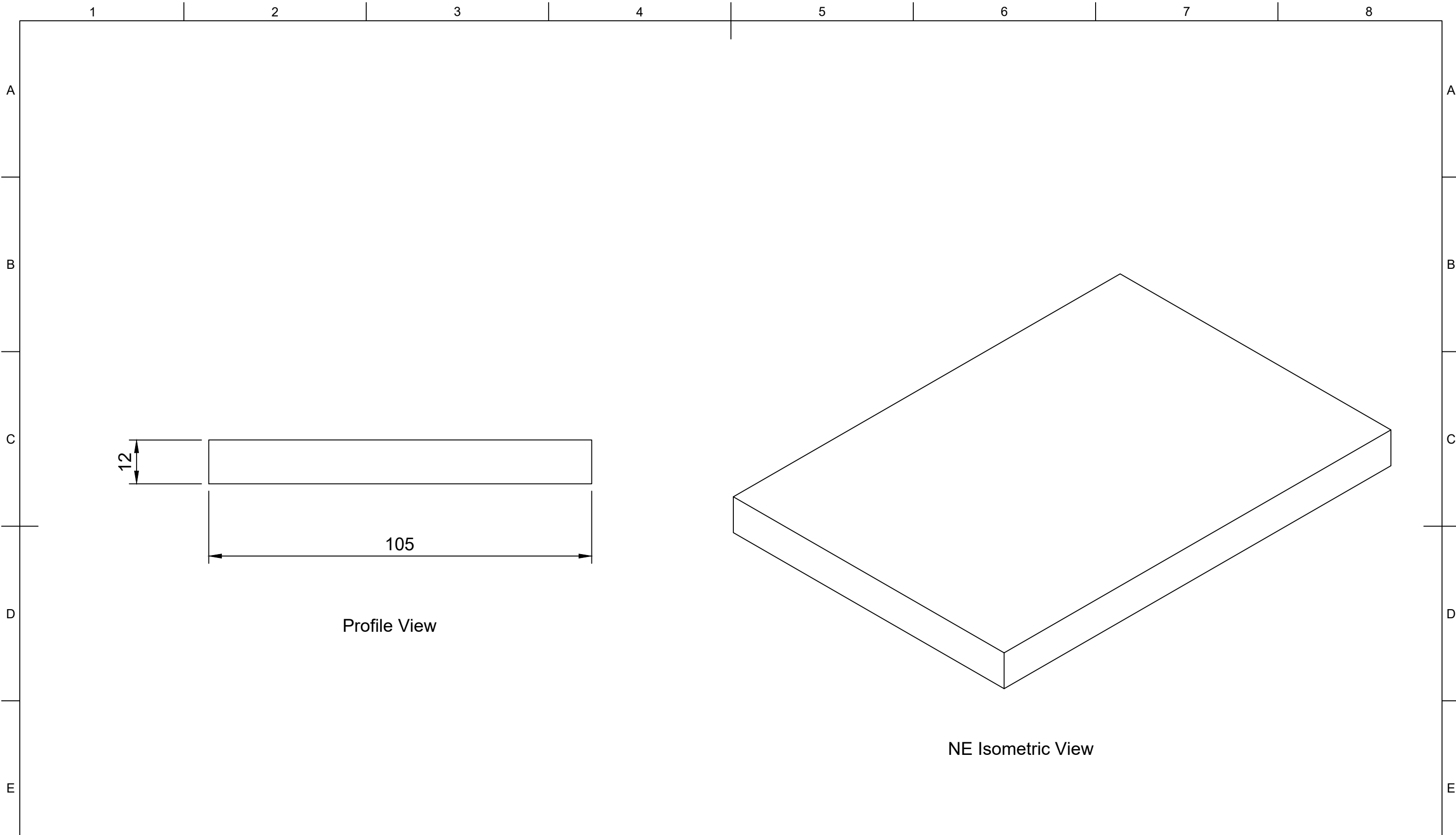

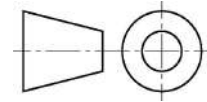
	Part Number				Created By		Cross Sectional Area (mm²)		Nominal Dimension (mm)		Tolerance, ± (mm)	
	207668				Isaac Erskine		1260		Greater Than	Less Than or Equal to		
	Description				Date Drawn		Material		0.00	1.50	0.40	
	Rectangle - Solid				04/11/2020		EPDM		1.50	2.50	0.50	
	Revision				Approved By		Hardness (Shore A)		2.50	4.00	0.70	
	A	14/02/2022		Sheet Scale		Date of Approval		70		4.00	6.30	0.80
		14/02/2022		1:1		Date of Approval		Black		6.30	10.00	1.00
		14/02/2022		A3		Date of Approval		Black		10.00	16.00	1.30
		14/02/2022		1/1		Date of Approval		Black		16.00	25.00	1.60
		14/02/2022		1/1		Date of Approval		Black		25.00	40.00	2.00
Projection				Weight (kg/m)		1.588		40.00	63.00	2.50		
3rd Agl. 				1.588		1.588		63.00	100.00	3.20		
1.588				1.588		1.588		100.00		3.20%		

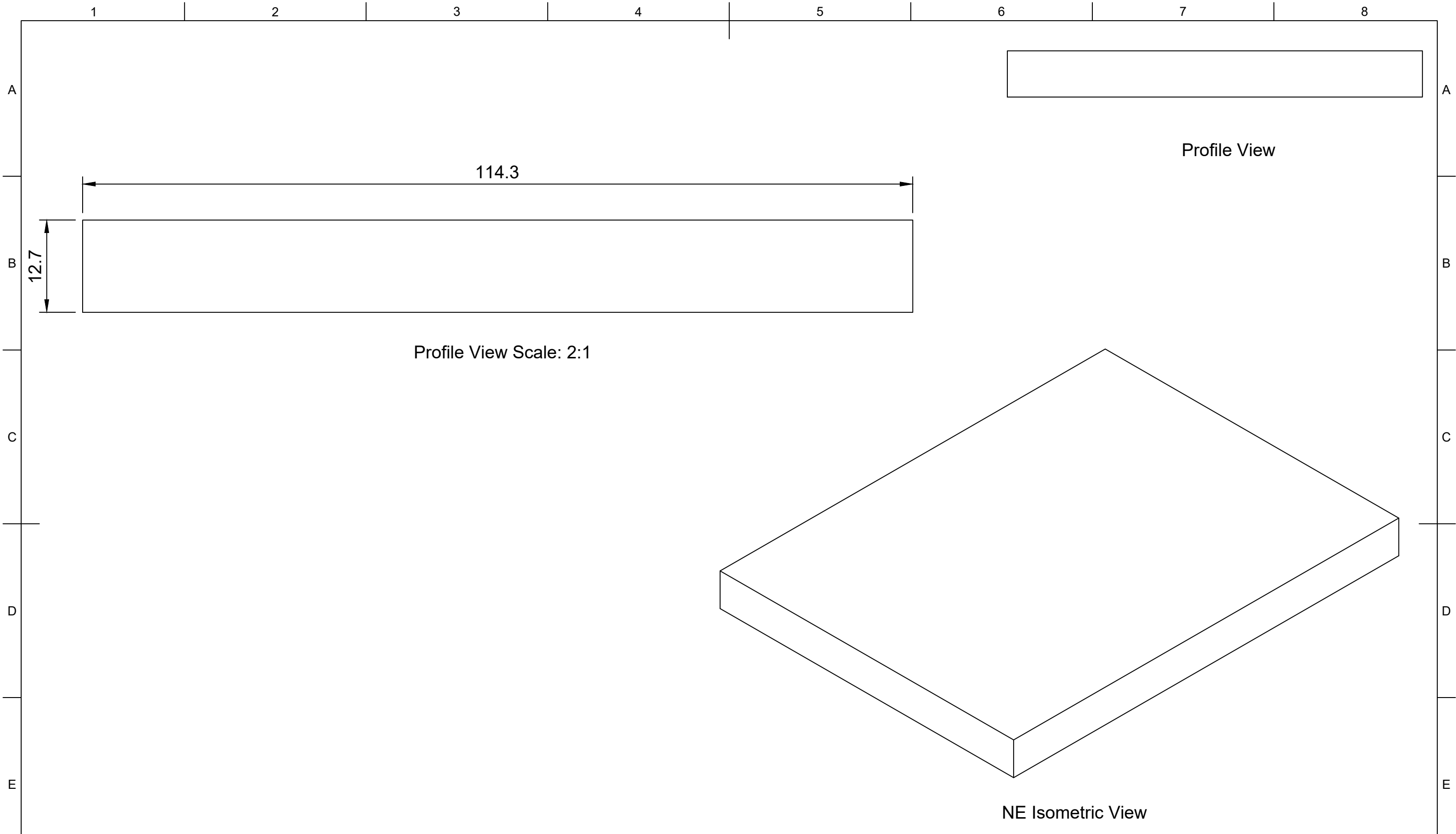

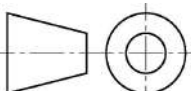
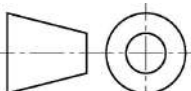
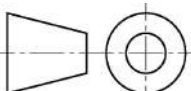
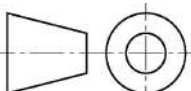
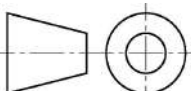
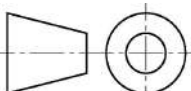
	Part Number				Created By		Cross Sectional Area (mm²)		Nominal Dimension (mm)		Tolerance, ± (mm)	
	203246				Isaac Erskine		1452		Greater Than	Less Than or Equal to		
	Description				Date Drawn		Material		0.00	1.50	0.40	
	Rectangle - Solid				25/07/2020		EPDM		1.50	2.50	0.50	
	Revision				Approved By		Hardness (Shore A)		2.50	4.00	0.70	
	A	14/02/2022		1:1		Date of Approval		70		4.00	6.30	0.80
	Date of Issue		Sheet Scale		Sheet Size		Weight (kg/m)		6.30	10.00	1.00	
	14/02/2022		1:1		A3		3rd Agl. 		10.00	16.00	1.30	
	14/02/2022		1:1		A3		3rd Agl. 		16.00	25.00	1.60	
	14/02/2022		1:1		A3		3rd Agl. 		25.00	40.00	2.00	
14/02/2022		1:1		A3		3rd Agl. 		40.00	63.00	2.50		
14/02/2022		1:1		A3		3rd Agl. 		63.00	100.00	3.20		
14/02/2022		1:1		A3		3rd Agl. 		100.00	—	3.20%		

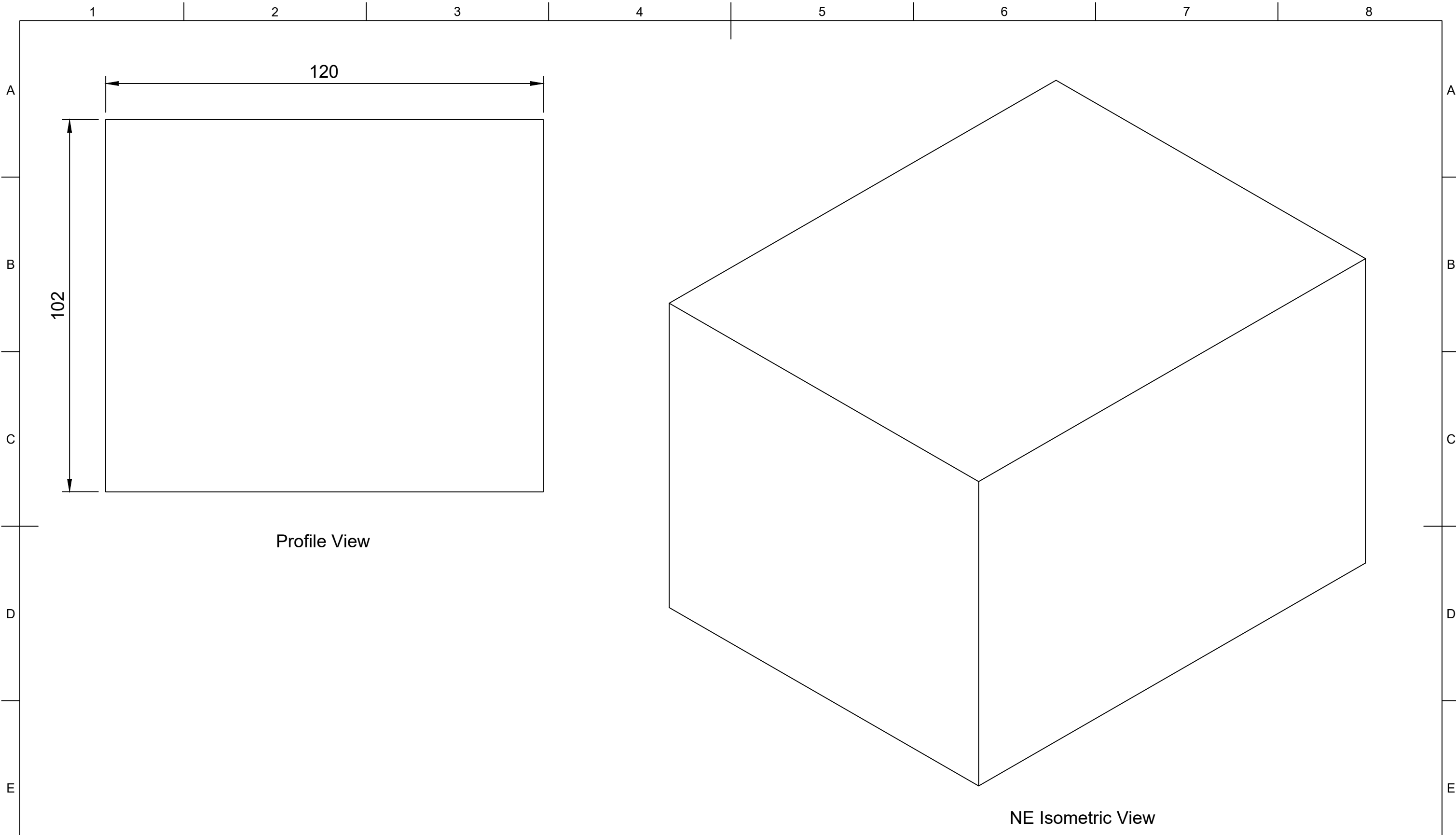

Profile View

NE Isometric View

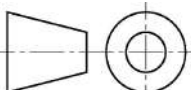
	Part Number				Created By		Cross Sectional Area (mm²)		Nominal Dimension (mm)		Tolerance, ± (mm)	
	203868				Isaac Erskine		12240		Greater Than	Less Than or Equal to		
	Description				Date Drawn		Material		0.00	1.50	0.40	
					25/07/2020		EPDM		1.50	2.50	0.50	
	Rectangle - Solid				Approved By		Hardness (Shore A)		2.50	4.00	0.70	
					Date of Approval		70		4.00	6.30	0.80	
							Black		6.30	10.00	1.00	
	Revision		Date of Issue		Sheet Scale		Sheet Size		Sheet		Projection	
	A		14/02/2022		1:1		A3		1/1		3rd Agl. 	
											Weight (kg/m)	
										15.422		
								25.00	40.00	2.00		
								40.00	63.00	2.50		
								63.00	100.00	3.20		
								100.00		3.20%		

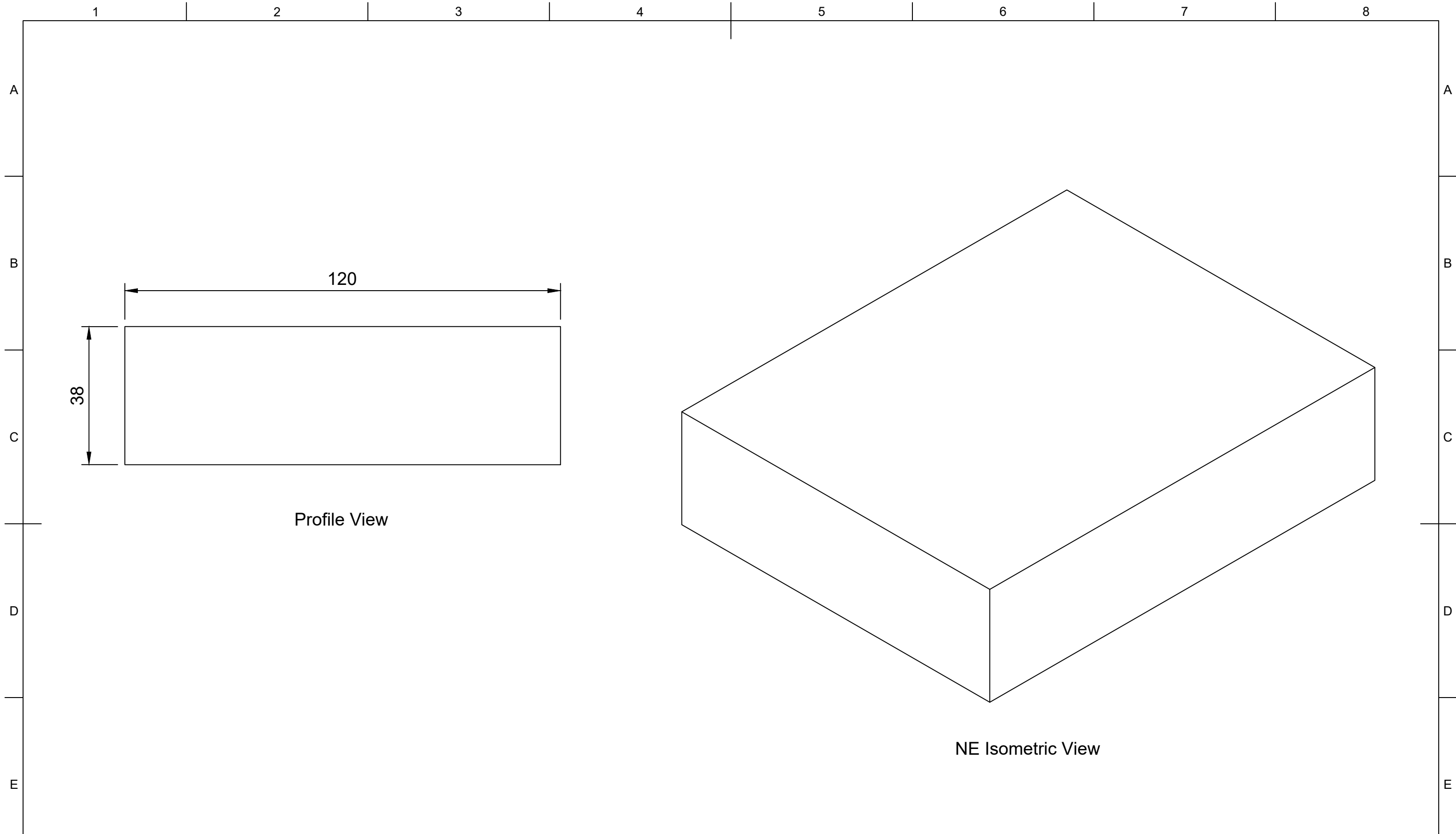

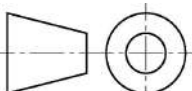
	Part Number				Created By		Cross Sectional Area (mm²)		Nominal Dimension (mm)		Tolerance, ± (mm)			
	206822				Isaac Erskine		4560		Greater Than	Less Than or Equal to				
	Description				Date Drawn		Material		0.00	1.50	0.40			
	Rectangle - Solid				25/07/2020		EPDM		1.50	2.50	0.50			
	Revision				Approved By		Hardness (Shore A)		2.50	4.00	0.70			
	A	Date of Issue		Sheet Scale		Sheet Size		Sheet		Date of Approval		Colour		
		14/02/2022		1:1		A3		1/1		3rd Agl. 		Black		
										Weight (kg/m)		10.00	16.00	1.30
										5.746		16.00	25.00	1.60
												25.00	40.00	2.00
											40.00	63.00	2.50	
											63.00	100.00	3.20	
											100.00		3.20%	

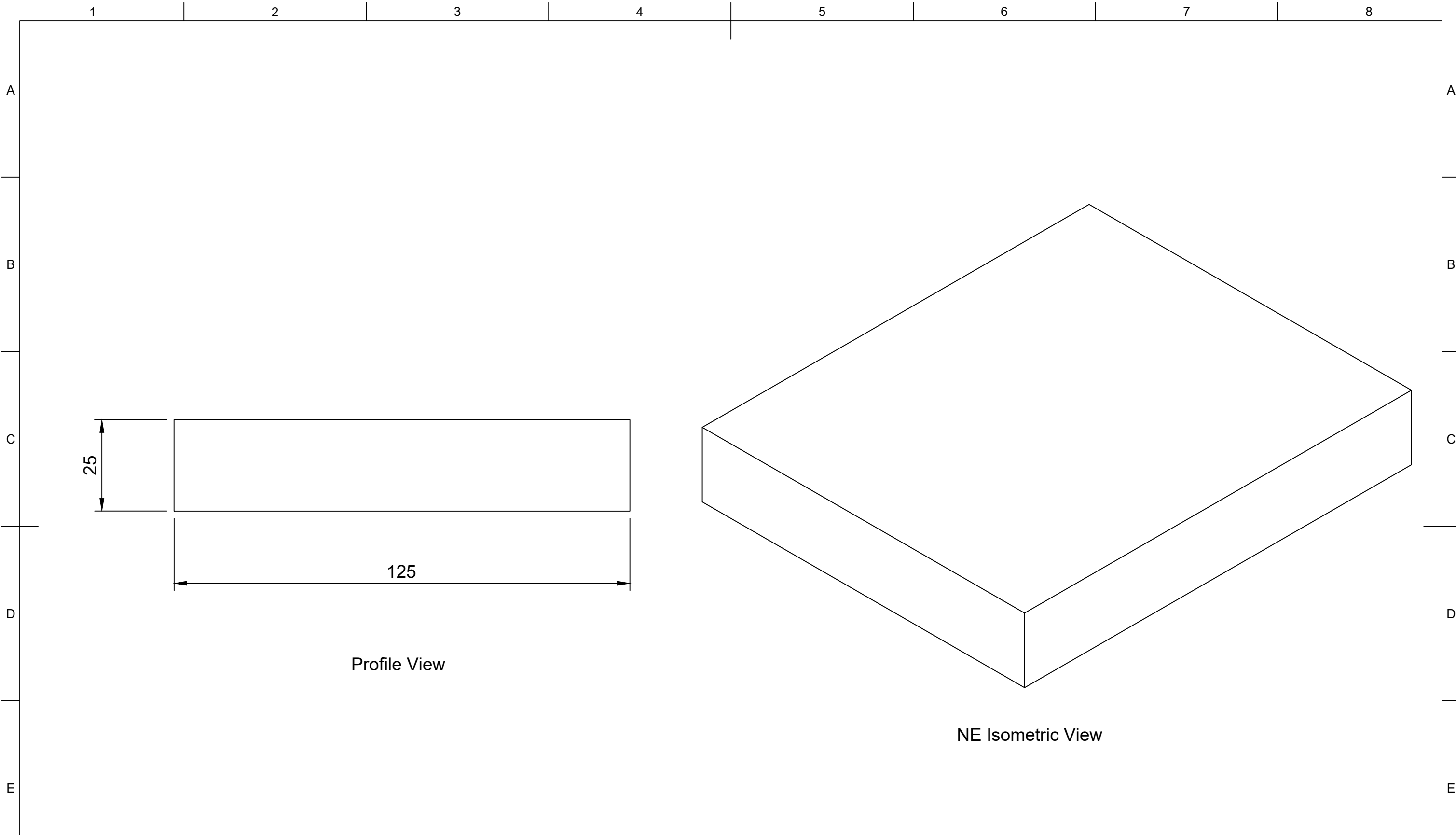

	Part Number				Created By		Cross Sectional Area (mm²)		Nominal Dimension (mm)		Tolerance, ± (mm)	
	200971				Isaac Erskine		3125		Greater Than	Less Than or Equal to		
	Description				Date Drawn		Material		0.00	1.50	0.40	
	Rectangle - Solid				04/11/2020		EPDM		1.50	2.50	0.50	
	Revision				Approved By		Hardness (Shore A)		2.50	4.00	0.70	
	A	14/02/2022				70		4.00		6.30	1.00	
	Date of Issue		Sheet Scale		Sheet Size		Sheet		Colour		6.30	10.00
	14/02/2022		1:1		A3		1/1		Black		10.00	16.00
	Projection		Weight (kg/m)		3rd Agl.		3.938		16.00	25.00	1.60	
									25.00	40.00	2.00	
								40.00	63.00	2.50		
								63.00	100.00	3.20		
								100.00		3.20%		

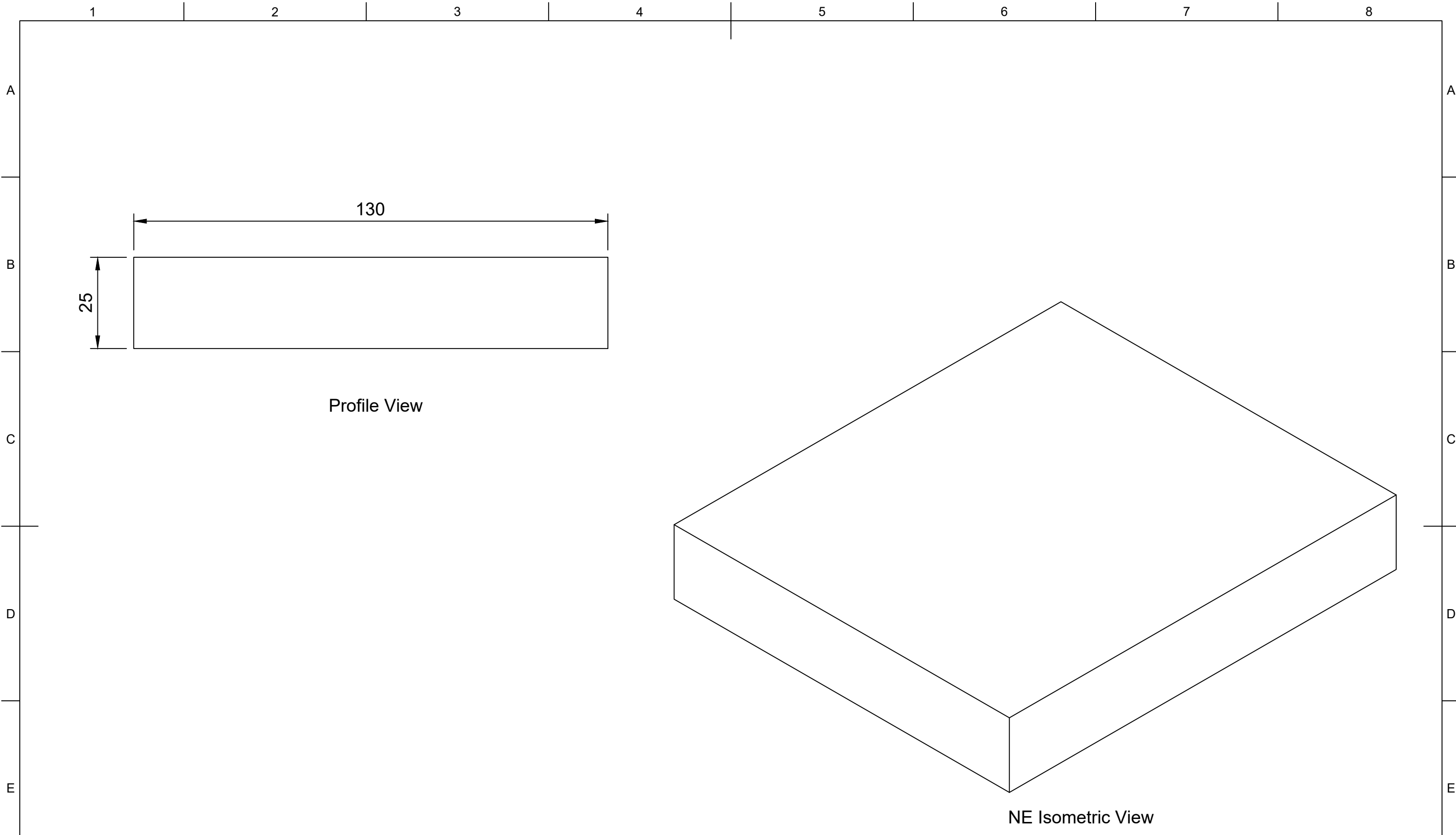

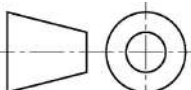
	Part Number				Created By		Cross Sectional Area (mm²)		Nominal Dimension (mm)		Tolerance, ± (mm)		
	203997				Isaac Erskine		3250		Greater Than	Less Than or Equal to			
	Description				Date Drawn		Material		0.00	1.50	0.40		
	Rectangle - Solid				29/07/2020		Nitrile		1.50	2.50	0.50		
	Revision				Approved By		Hardness (Shore A)		2.50	4.00	0.70		
	A	Date of Issue		Sheet Scale		Sheet Size		Sheet		Date of Approval		Colour	
		14/02/2022		1:1		A3		1/1		70		Black	
										Date of Approval		Weight (kg/m)	
										3rd Agl. 		3.993	
										25.00	40.00	2.00	
									40.00	63.00	2.50		
									63.00	100.00	3.20		
									100.00		3.20%		

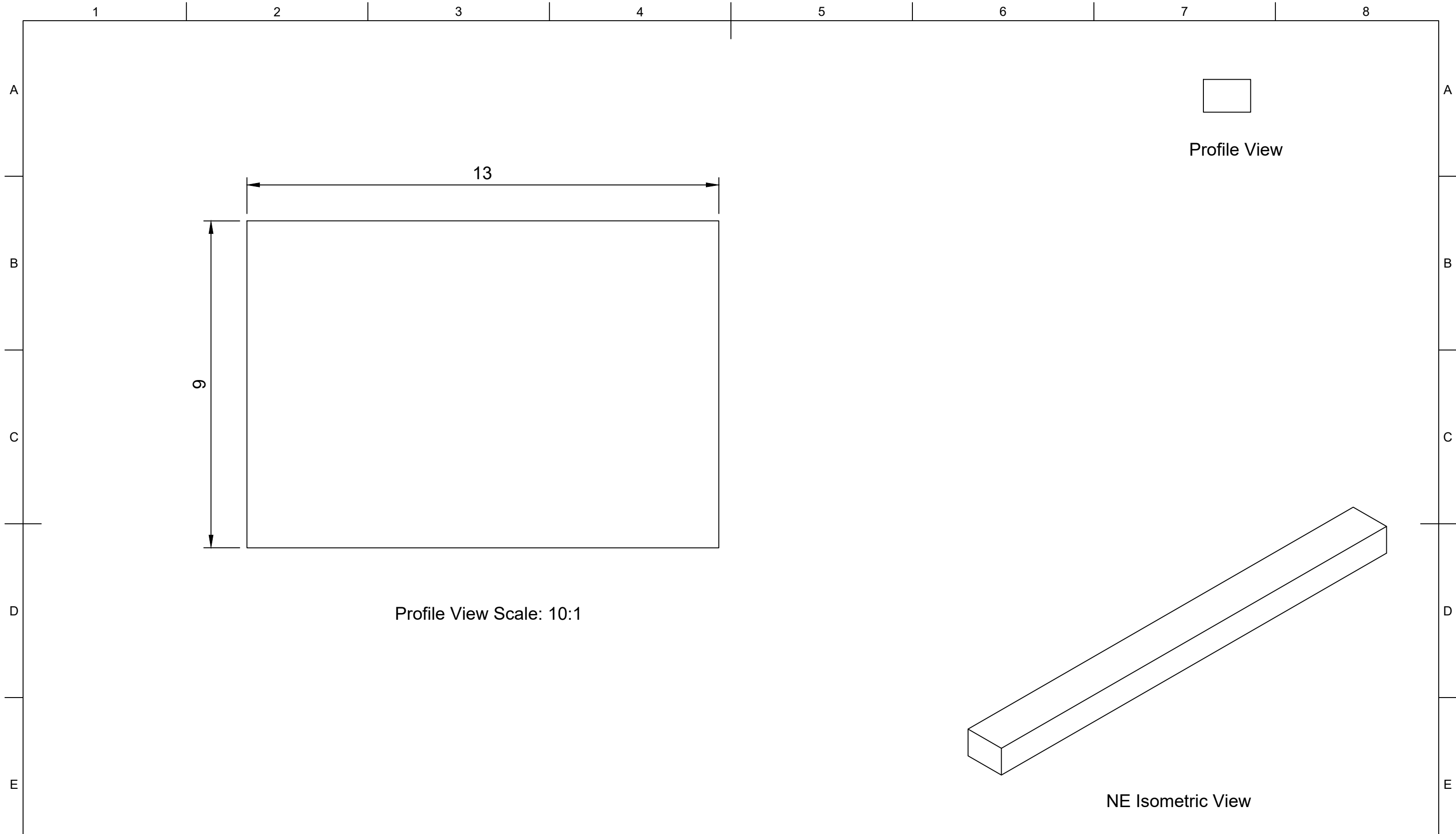

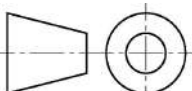
	Part Number				Created By		Cross Sectional Area (mm²)		Nominal Dimension (mm)		Tolerance, ± (mm)	
	205479				David Stirling		117		Greater Than	Less Than or Equal to		
	Description				Date Drawn		Material		0.00	1.50	0.40	
	Rectangle - Solid				29/07/2020		EPDM		1.50	2.50	0.50	
	Revision				Approved By		Hardness (Shore A)		2.50	4.00	0.70	
	A	31/01/2022		Sheet Scale		Date of Approval		70		4.00	6.30	0.80
		1:1		Sheet Size		Colour		Black		6.30	10.00	1.00
		A3		Sheet		Weight (g/m)		147		10.00	16.00	1.30
		1/1		Projection		3rd Agl.				16.00	25.00	1.60
										25.00	40.00	2.00
									40.00	63.00	2.50	
									63.00	100.00	3.20	
									100.00		3.20%	

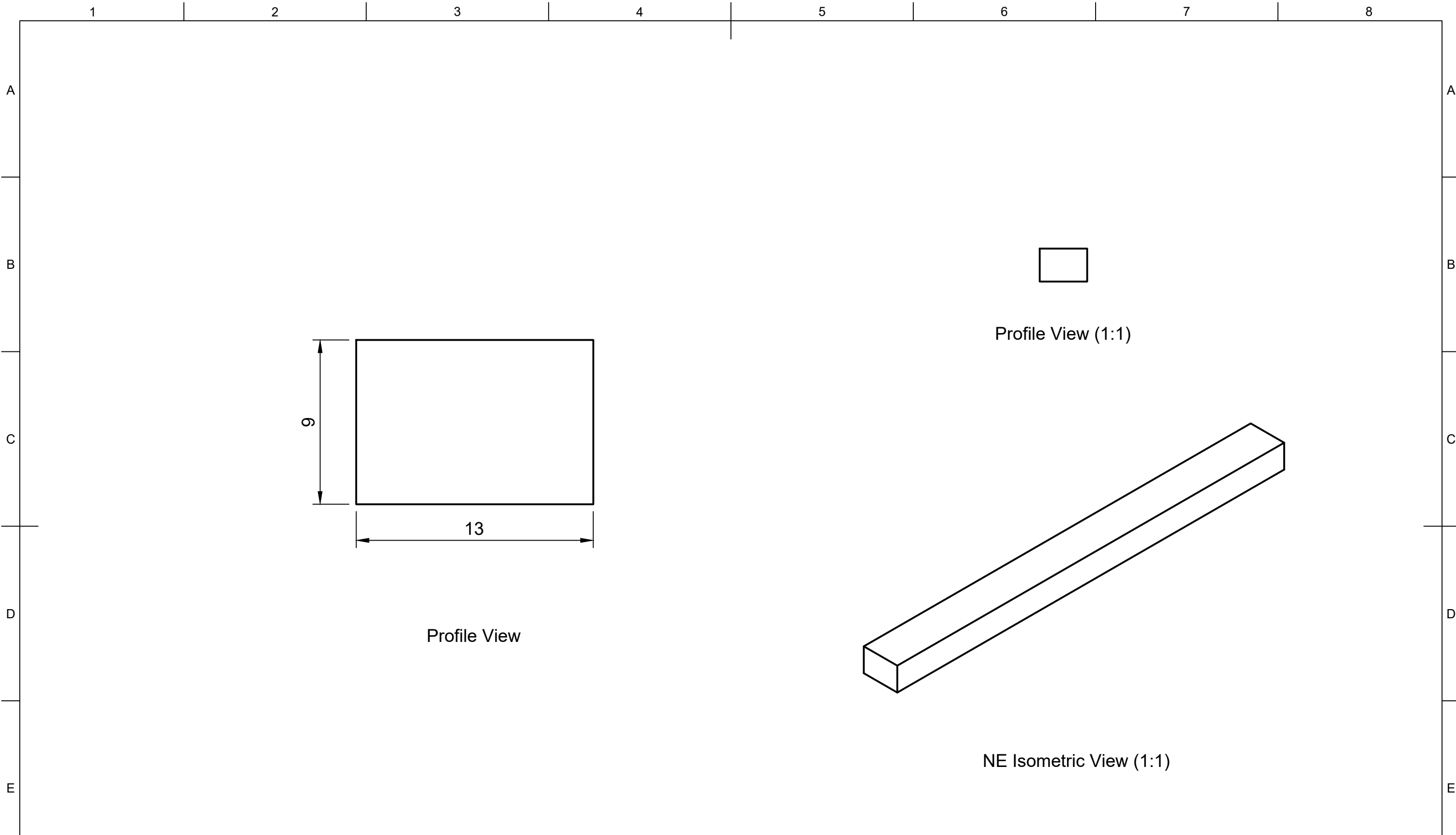

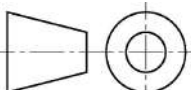
	Part Number				Created By		Cross Sectional Area (mm²)		Nominal Dimension (mm)		Tolerance, ± (mm)		
	206813				David Stirling		117		Greater Than	Less Than or Equal to			
	Description				Date Drawn		Material		0.00	1.50	0.40		
					31/01/2022		Nitrile		1.50	2.50	0.50		
	Rectangle - Solid				Approved By		Hardness (Shore A)		2.50	4.00	0.70		
					Date of Approval		70		4.00	6.30	0.80		
	Revision				Date of Issue		Projection		Colour		6.30	10.00	1.00
											10.00		Black
	A				31/01/2022		3rd Agl. 		Weight (g/m)		25.00	40.00	2.00
	5:1				A3		1/1		144		40.00	63.00	2.50
										63.00	100.00	3.20	
										100.00		3.20%	

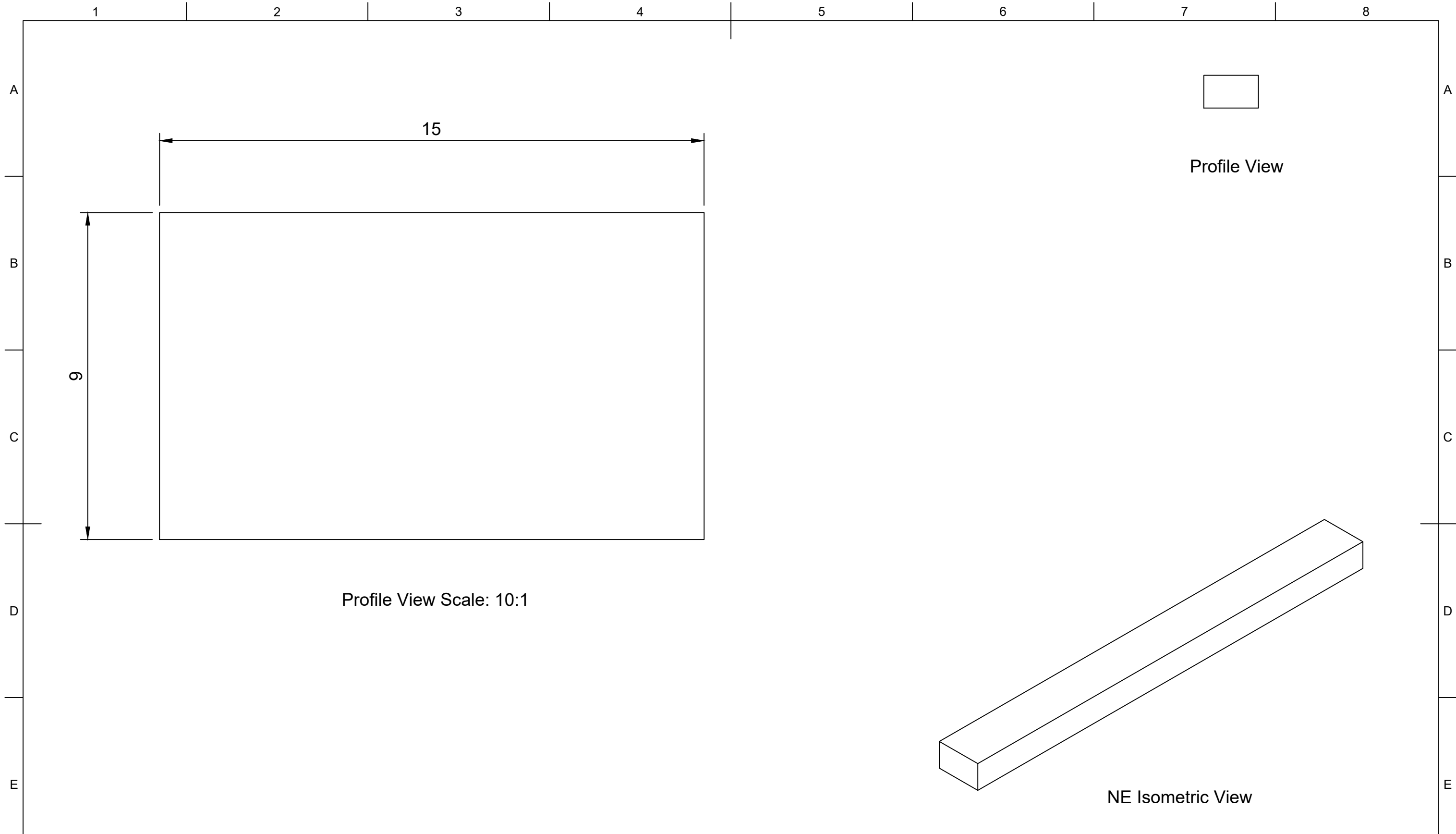

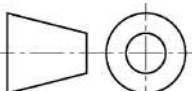
	Part Number				Created By		Cross Sectional Area (mm²)		Nominal Dimension (mm)		Tolerance, ± (mm)
	206003				Isaac Erskine		135		Greater Than	Less Than or Equal to	
					Date Drawn		Material		0.00	1.50	0.40
					29/07/2020		EPDM		1.50	2.50	0.50
	Description				Approved By		Hardness (Shore A)		2.50	4.00	0.70
	Rectangle - Solid						70		4.00	6.30	0.80
					Date of Approval		Colour		6.30	10.00	1.00
							Black		10.00	16.00	1.30
					Projection		Weight (g/m)		16.00	25.00	1.60
					3rd Agl. 		170		25.00	40.00	2.00
Revision	Date of Issue	Sheet Scale	Sheet Size	Sheet					40.00	63.00	2.50
A	14/02/2022	1:1	A3	1/1					63.00	100.00	3.20
										100.00	3.20%

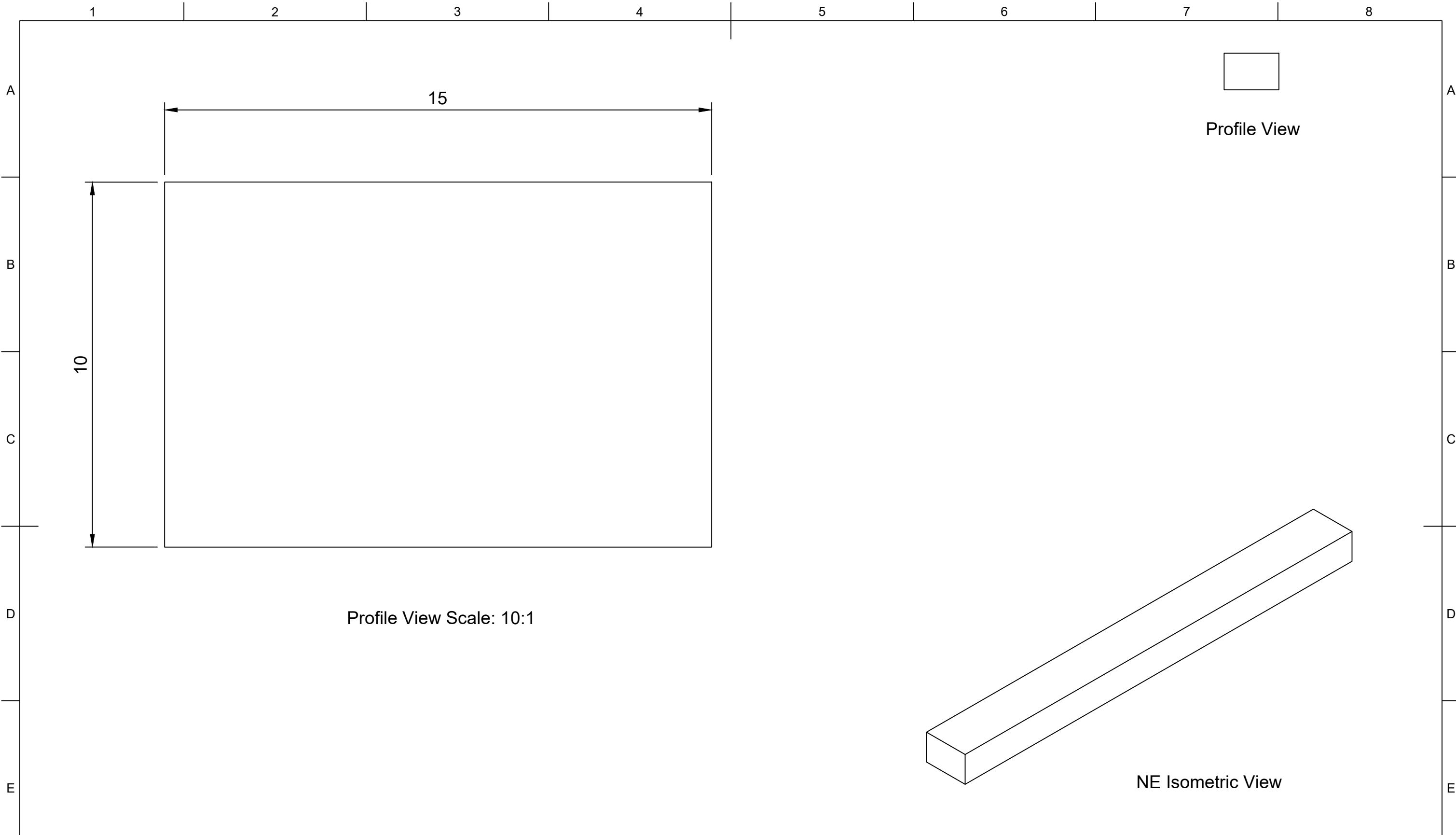

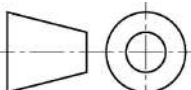
	Part Number				Created By		Cross Sectional Area (mm²)		Nominal Dimension (mm)		Tolerance, ± (mm)
	202804				Isaac Erskine		150		Greater Than	Less Than or Equal to	
	Description				Date Drawn		Material		0.00		0.40
	Rectangle - Solid				29/07/2020		EPDM		1.50		0.50
	Revision				Approved By		Hardness (Shore A)		2.50		0.70
	A				Date of Approval		70		4.00		0.80
	Date of Issue				Projection		Colour		6.30		1.00
	14/02/2022				3rd Agl. 		Black		10.00		1.30
	Sheet Scale				Weight (g/m)		189		16.00		1.60
	1:1								25.00		2.00
Sheet Size								40.00		2.50	
A3								63.00		3.20	
Sheet								100.00		3.20%	
1/1											

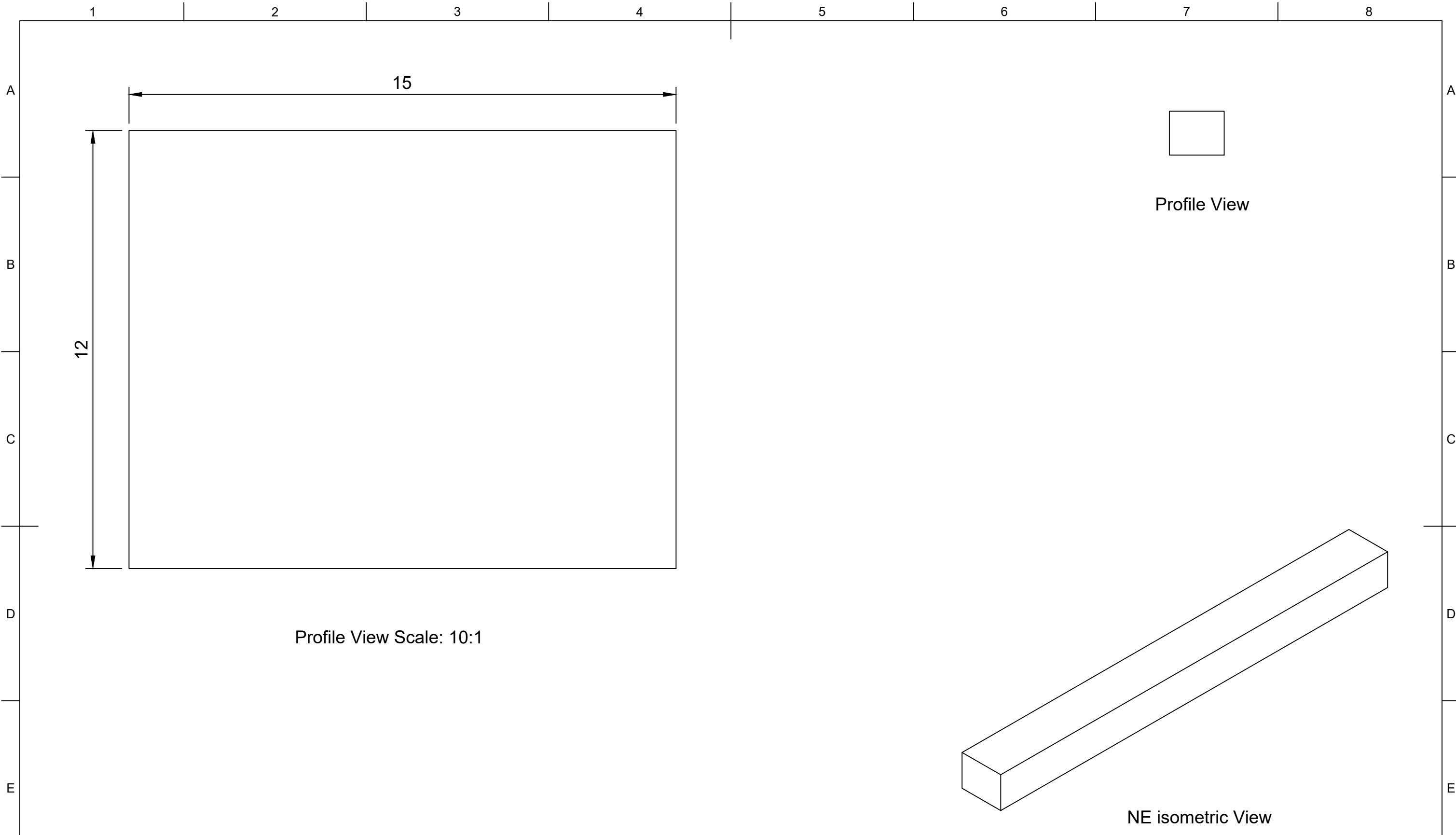

	Part Number				Created By		Cross Sectional Area (mm²)		Nominal Dimension (mm)		Tolerance, ± (mm)	
	208141				Isaac Erskine		180		Greater Than	Less Than or Equal to		
	Description				Date Drawn		Material		0.00	1.50	0.40	
	Rectangle - Solid				29/07/2020		EPDM		1.50	2.50	0.50	
	Revision				Approved By		Hardness (Shore A)		2.50	4.00	0.70	
	A	Date of Issue		Sheet Scale		Date of Approval		Colour		4.00	6.30	0.80
		14/02/2022		1:1				Black		6.30	10.00	1.00
				A3		Projection		Weight (g/m)		10.00	16.00	1.30
				1/1		3rd Agl.				16.00	25.00	1.60
										25.00	40.00	2.00
									40.00	63.00	2.50	
									63.00	100.00	3.20	
									100.00		3.20%	

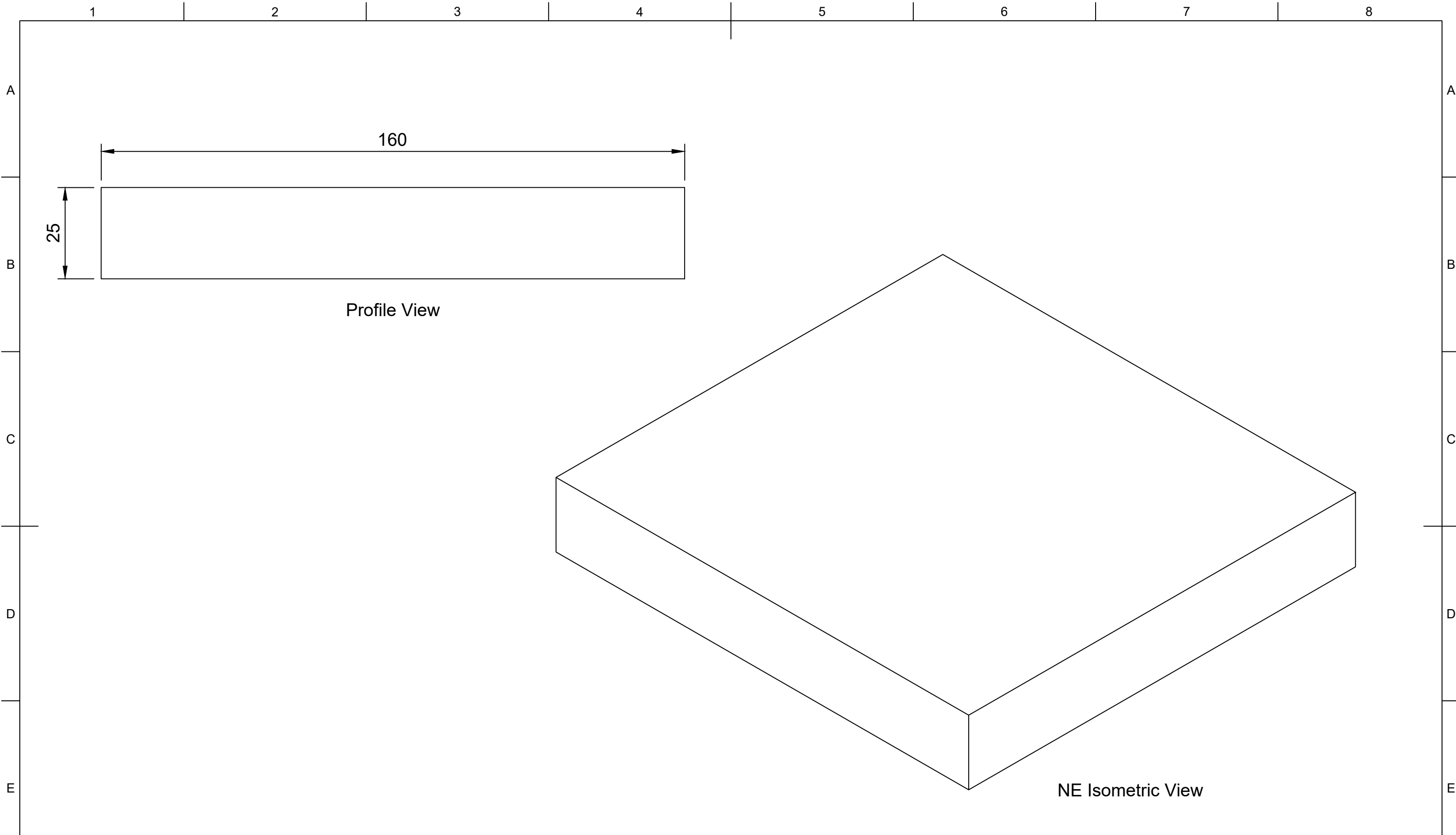

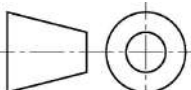
	Part Number				Created By		Cross Sectional Area (mm²)		Nominal Dimension (mm)		Tolerance, ± (mm)	
	205379				Isaac Erskine		4000		Greater Than	Less Than or Equal to		
	Description				Date Drawn		Material		0.00	1.50	0.40	
	Rectangle - Solid				29/07/2020		EPDM		1.50	2.50	0.50	
	Revision				Approved By		Hardness (Shore A)		2.50	4.00	0.70	
	A	Date of Issue		Sheet Scale		Date of Approval		70		4.00	6.30	0.80
		14/02/2022		1:1				Black		6.30	10.00	1.00
				Sheet Size		Projection		Weight (g/m)		10.00	16.00	1.30
				A3		3rd Agl. 		5.040		16.00	25.00	1.60
				1/1						25.00	40.00	2.00
									40.00	63.00	2.50	
									63.00	100.00	3.20	
									100.00		3.20%	

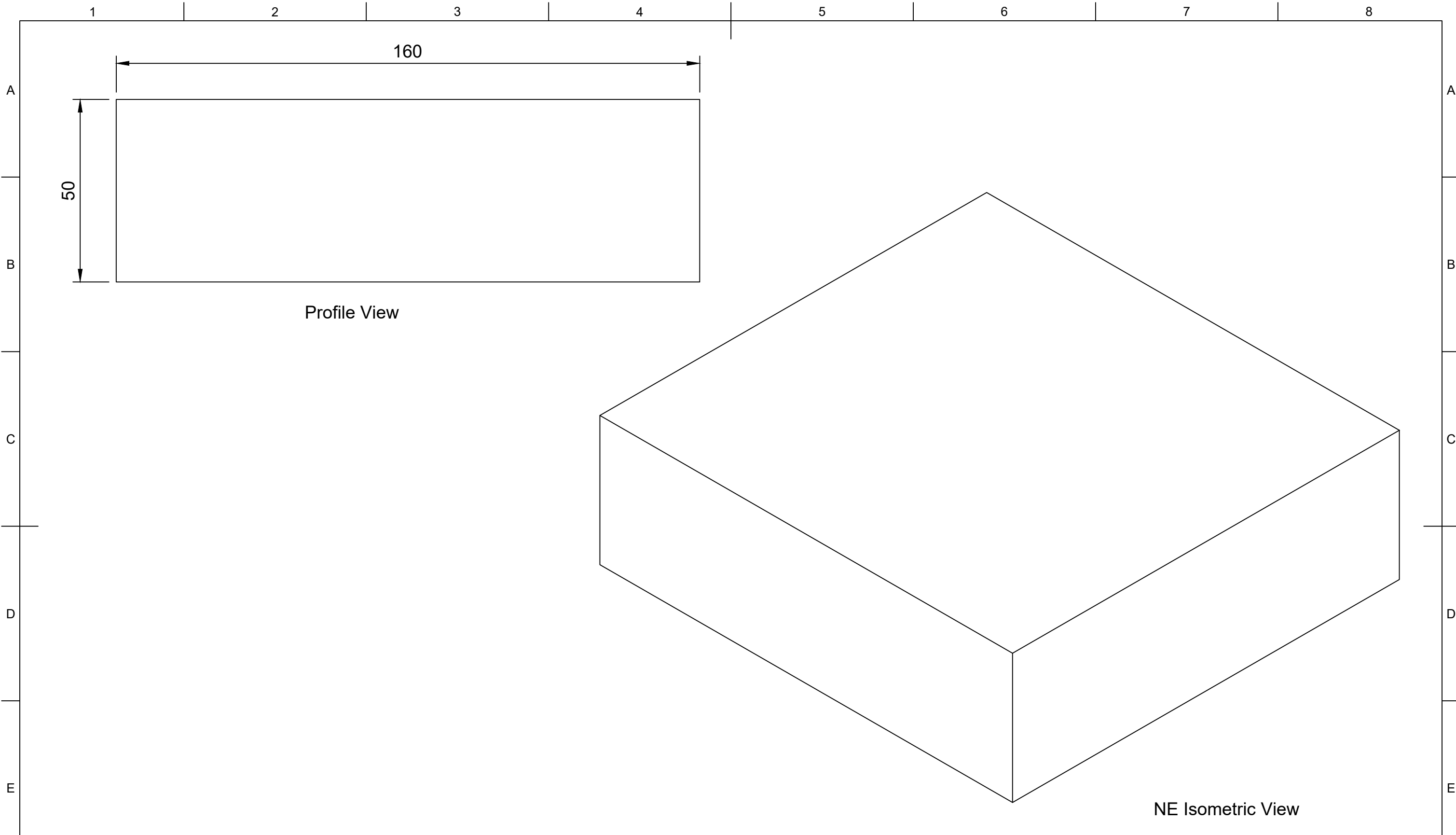

Profile View

NE Isometric View

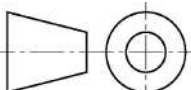
	Part Number				Created By		Cross Sectional Area (mm²)		Nominal Dimension (mm)		Tolerance, ± (mm)		
	209642				Isaac Erskine		8000		Greater Than	Less Than or Equal to			
	Description				Date Drawn		Material		0.00	1.50	0.40		
					29/07/2020		Neoprene		1.50	2.50	0.50		
	Rectangle - Solid				Approved By		Hardness (Shore A)		2.50	4.00	0.70		
					Date of Approval		70		4.00	6.30	0.80		
	Revision				Date of Issue		Projection		Colour		6.30	10.00	1.00
											14/02/2022		3rd Agl. 
	A				1:1		Sheet Size		Weight (kg/m)		16.00	25.00	1.60
	14/02/2022				A3		1/1		12.160		25.00	40.00	2.00
										40.00	63.00	2.50	
										63.00	100.00	3.20	
										100.00		3.20%	

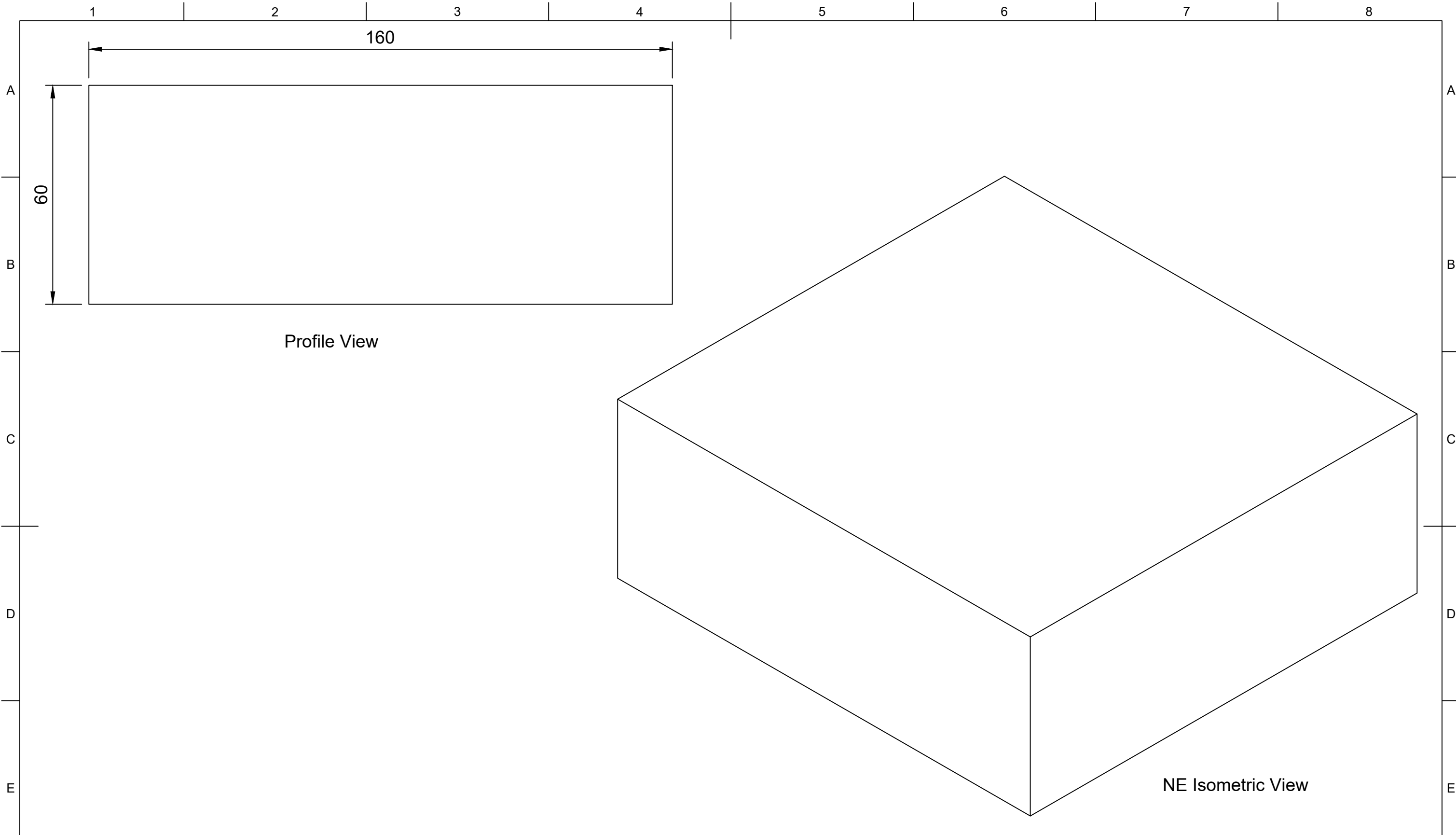

Profile View

NE Isometric View

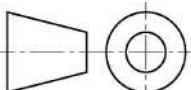
	Part Number				Created By		Cross Sectional Area (mm²)		Nominal Dimension (mm)		Tolerance, ± (mm)
	209034				Isaac Erskine		9600		Greater Than	Less Than or Equal to	
	Description				Date Drawn		Material		0.00		0.40
	Rectangle - Solid				29/07/2020		EPDM		1.50		0.50
	Revision				Approved By		Hardness (Shore A)		2.50		0.70
	A				Date of Approval		70		4.00		0.80
	Date of Issue				Projection		Colour		6.30		1.00
	14/02/2022				3rd Agl. 		Black		10.00		1.30
	Sheet Scale				Weight (g/m)		12.096		16.00		1.60
	1:1								25.00		2.00
Sheet Size								40.00		2.50	
A3								63.00		3.20	
Sheet								100.00		3.20%	
1/1											

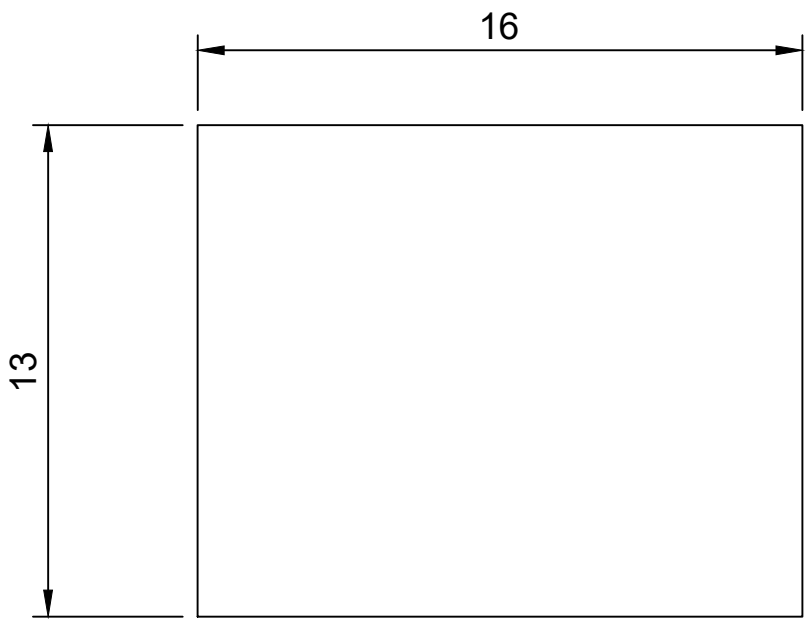
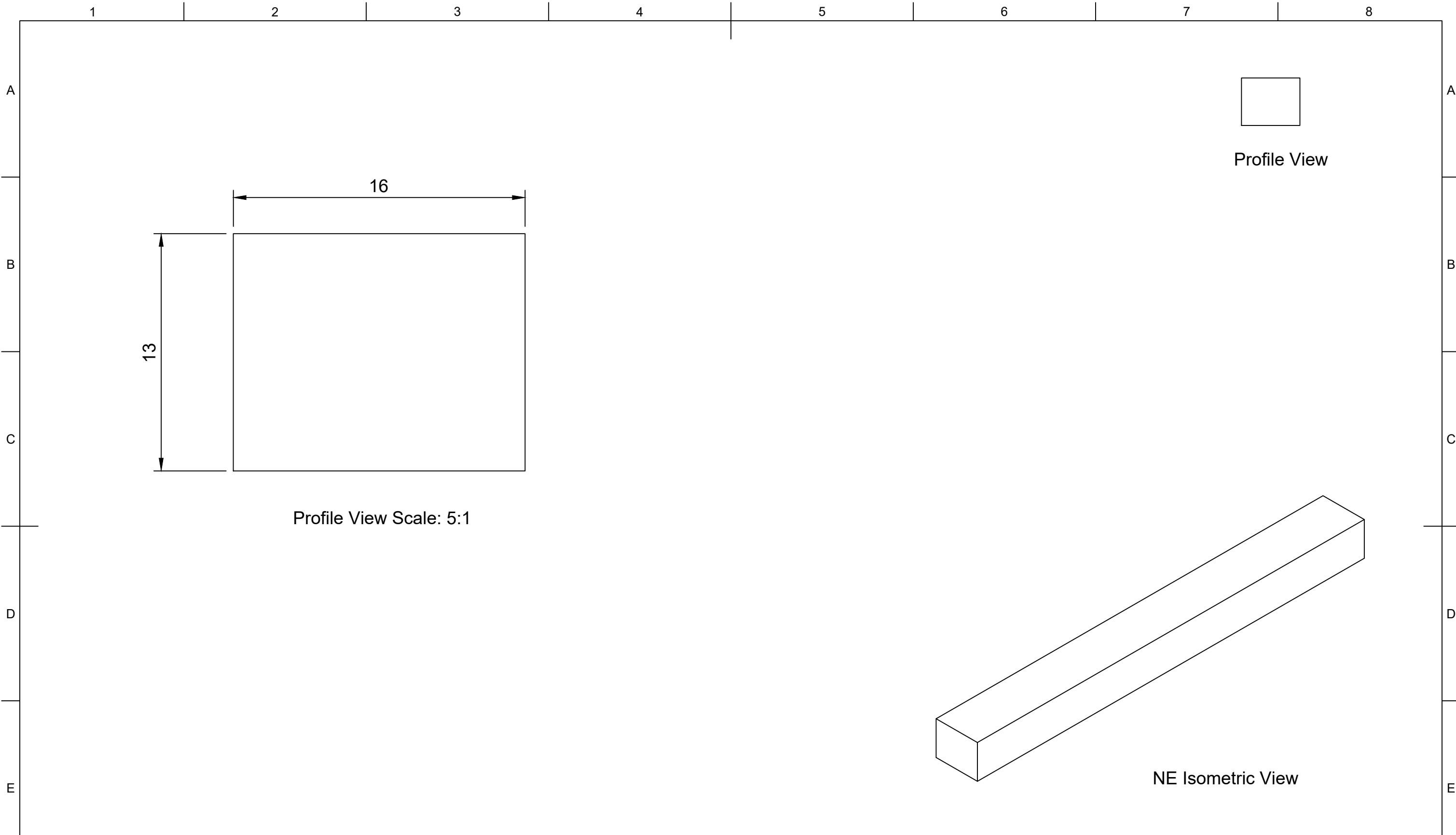

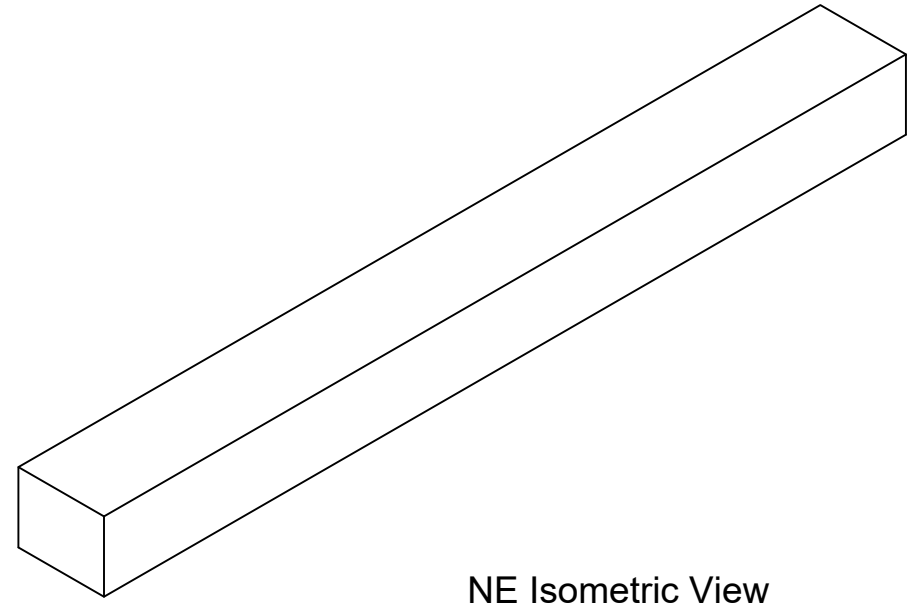

Profile View Scale: 5:1



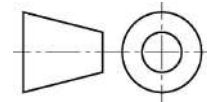

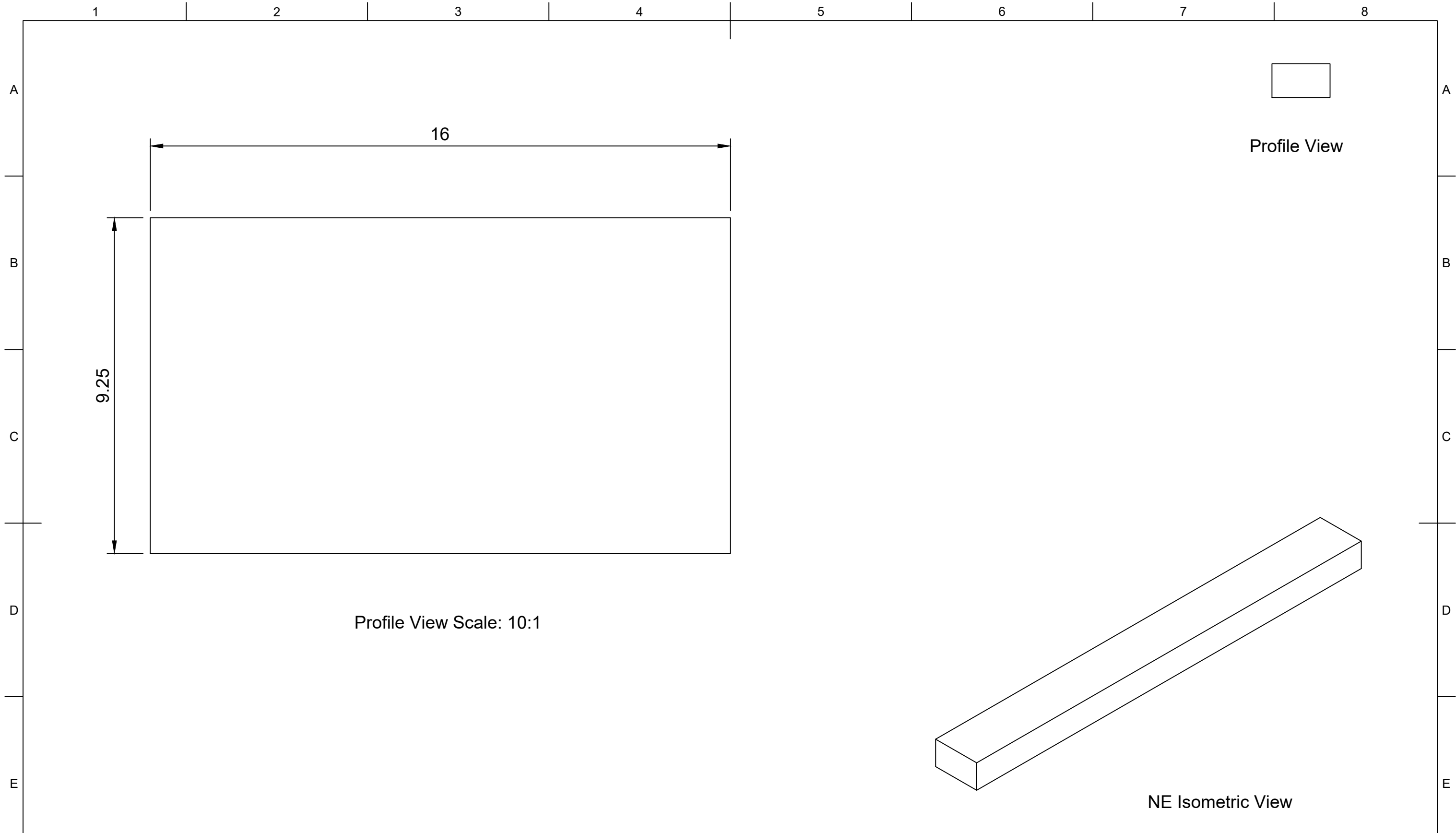
NE Isometric View

	Part Number				Created By		Cross Sectional Area (mm²)		Nominal Dimension (mm)		Tolerance, ± (mm)
	206401				Isaac Erskine		208		Greater Than	Less Than or Equal to	
	Description				Date Drawn		Material		0.00		0.40
	Rectangle - Solid				29/07/2020		Nitrile		1.50		0.50
	Revision				Approved By		Hardness (Shore A)		2.50		0.70
	A				Date of Approval		70		4.00		0.80
	Date of Issue				Projection		Colour		6.30		1.00
	14/02/2022				3rd Agl. 		Black		10.00		1.30
	Sheet Scale				Weight (g/m)		252		16.00		1.60
	1:1								25.00		2.00
Sheet Size								40.00		2.50	
A3								63.00		3.20	
Sheet								100.00		3.20%	
1/1											

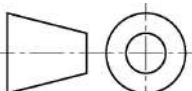

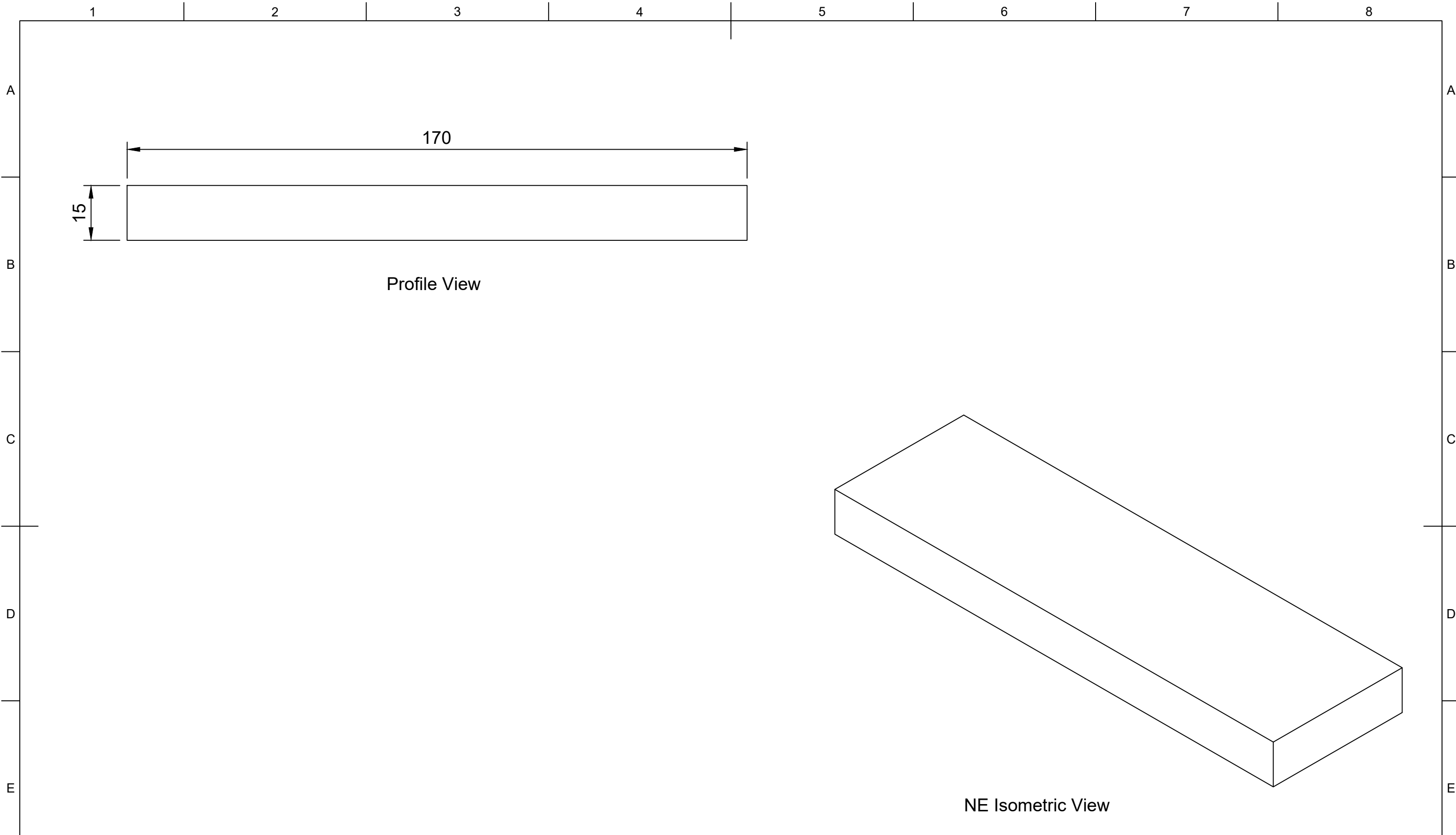
	Part Number				Created By		Cross Sectional Area (mm²)		Nominal Dimension (mm)		Tolerance, ± (mm)
	202667				Isaac Erskine		148		Greater Than	Less Than or Equal to	
	Description				Date Drawn		Material		0.00		0.40
	Rectangle - Solid				29/07/2020		Nitrile		1.50		0.50
	Revision				Approved By		Hardness (Shore A)		2.50		0.70
	A	15/02/2022		Isaac Erskine		70		4.00		0.80	
	Date of Issue		Sheet Scale		Date of Approval		Colour		6.30		1.00
	15/02/2022		1:1		15/02/2022		Black		10.00		1.30
	Sheet Size		Sheet		Projection		Weight (g/m)		16.00		1.60
	A3		1/1		3rd Agl. 		179		25.00		2.00
								40.00		2.50	
								63.00		3.20	
								100.00		3.20%	

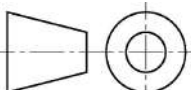

	Part Number				Created By		Cross Sectional Area (mm²)		Nominal Dimension (mm)		Tolerance, ± (mm)	
	205825				Isaac Erskine		2550		Greater Than	Less Than or Equal to		
	Description				Date Drawn		Material		0.00	1.50	0.40	
	Rectangle - Solid				31/07/2020		EPDM		1.50	2.50	0.50	
	Revision				Approved By		Hardness (Shore A)		2.50	4.00	0.70	
	A	Date of Issue		Sheet Scale	Sheet Size	Sheet	Isaac Erskine		4.00	6.30	0.80	
		15/02/2022		1:1	A3	1/1	15/02/2022		6.30	10.00	1.00	
							Date of Approval		10.00	16.00	1.30	
							15/02/2022		16.00	25.00	1.60	
							Projection		25.00	40.00	2.00	
						3rd Agl. 		Weight (kg/m)		40.00	63.00	2.50
								3.213		63.00	100.00	3.20
										100.00		3.20%

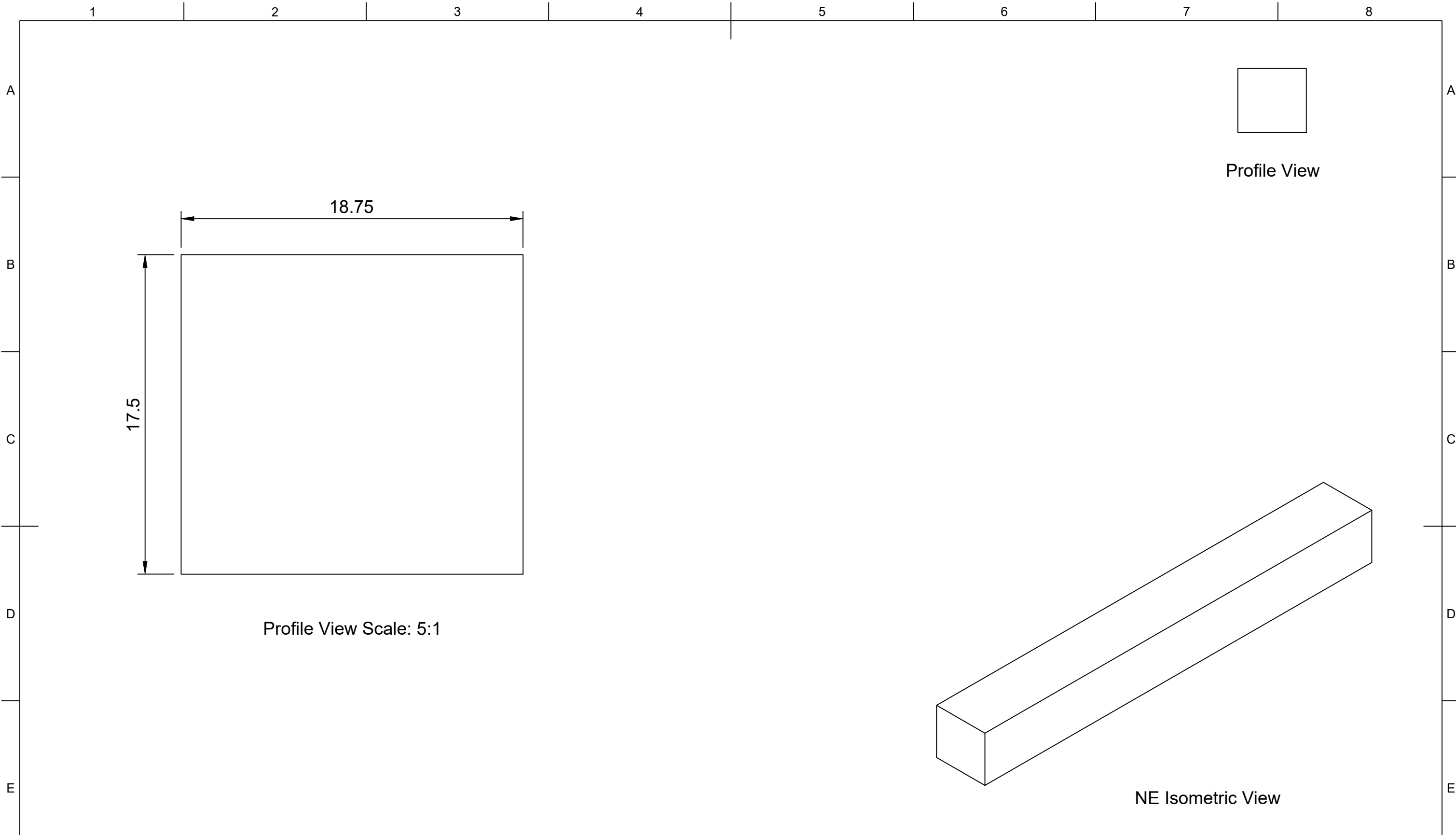

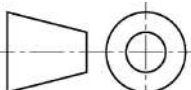
	Part Number				Created By		Cross Sectional Area (mm²)		Nominal Dimension (mm)		Tolerance, ± (mm)
	209937				Isaac Erskine		328		Greater Than	Less Than or Equal to	
	Description				Date Drawn		Material		0.00	1.50	0.40
	Rectangle - Solid				31/07/2020		EPDM		1.50	2.50	0.50
	Revision				Approved By		Hardness (Shore A)		2.50	4.00	0.70
	A	15/02/2022		Isaac Erskine		70		4.00	6.30	0.80	
	Date of Issue		Sheet Scale		Date of Approval		Colour		6.30	10.00	1.00
	15/02/2022		1:1		15/02/2022		Black		10.00	16.00	1.30
	Sheet Size		Sheet		Projection		Weight (g/m)		16.00	25.00	1.60
	A3		1/1		3rd Agl. 		413		25.00	40.00	2.00
								40.00	63.00	2.50	
								63.00	100.00	3.20	
								100.00		3.20%	

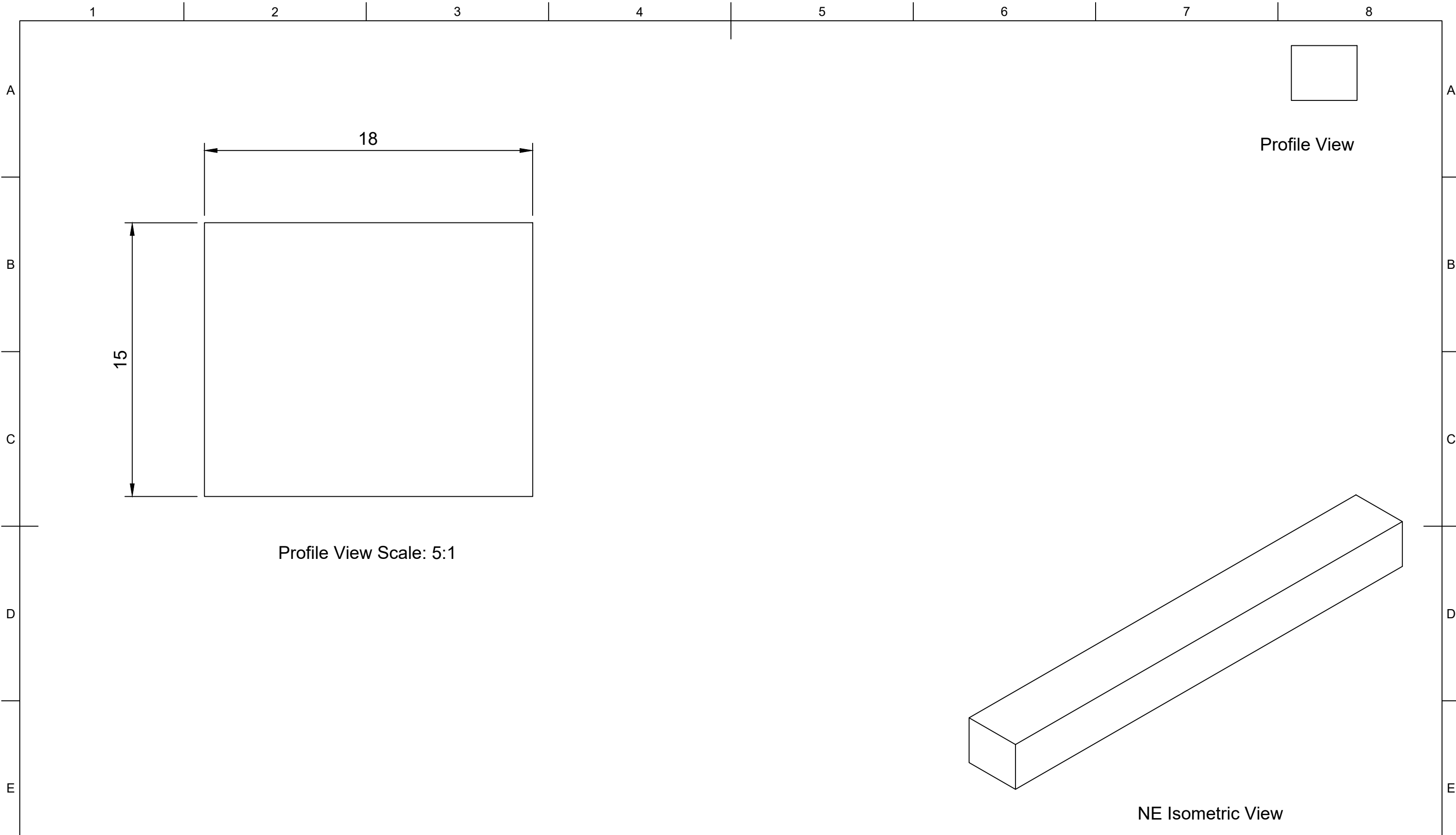

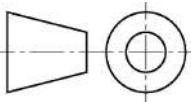
	Part Number				Created By		Cross Sectional Area (mm²)		Nominal Dimension (mm)		Tolerance, ± (mm)	
	204972				Isaac Erskine		270		Greater Than	Less Than or Equal to		
	Description				Date Drawn		Material		0.00		0.40	
	Rectangle - Solid				31/07/2020		EPDM		1.50		0.50	
	Revision				Approved By		Hardness (Shore A)		2.50		0.70	
	A	Date of Issue		Sheet Scale		Isaac Erskine		Colour		4.00		0.80
		15/02/2022		1:1		15/02/2022		Black		6.30		1.00
				Sheet Size		Date of Approval		Weight (g/m)		10.00		1.30
				A3		15/02/2022		340		16.00		1.60
				Sheet		Projection				25.00		2.00
			1/1		3rd Agl. 				40.00		2.50	
									63.00		3.20	
									100.00		3.20%	

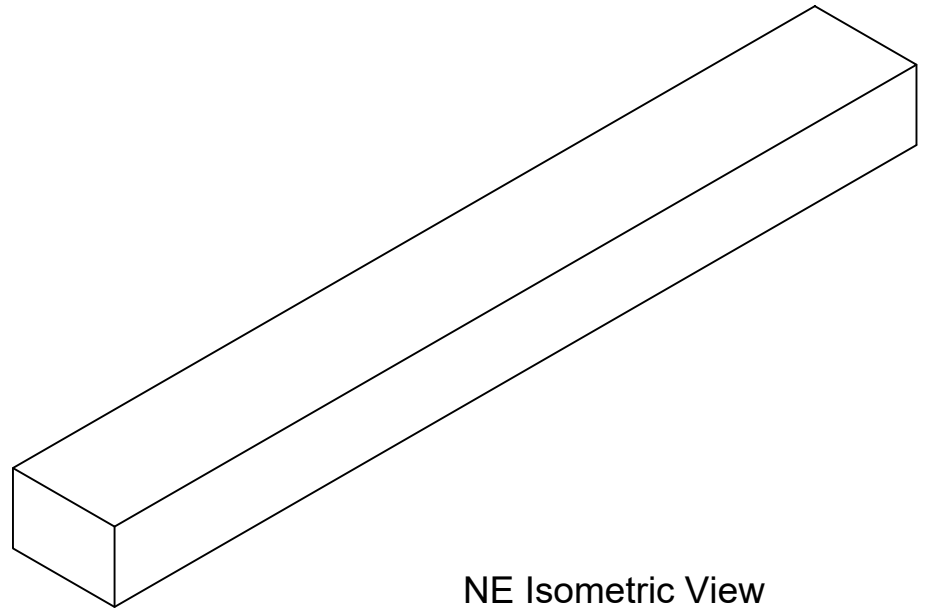
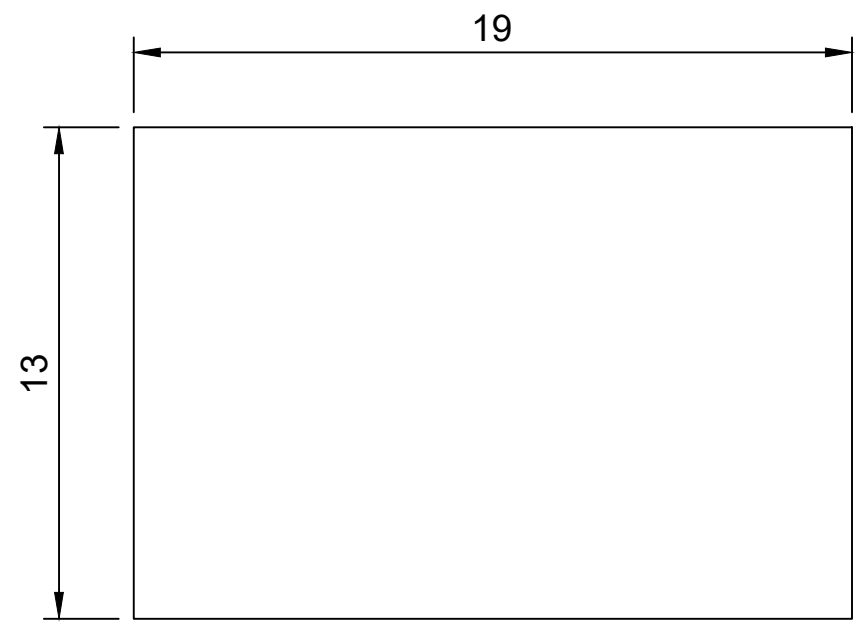
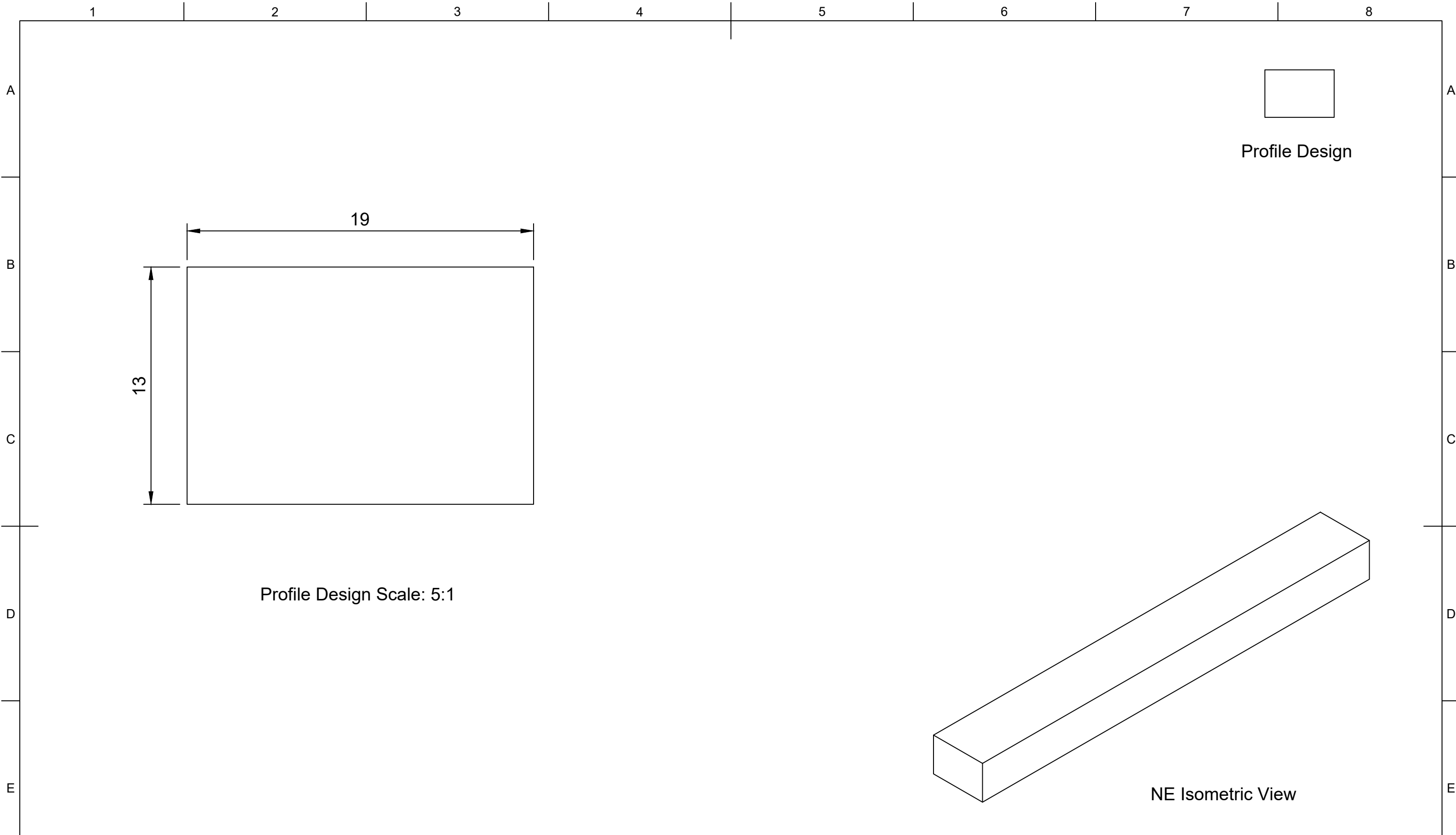

Profile Design Scale: 5:1

NE Isometric View

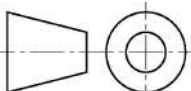
	Part Number				Created By		Cross Sectional Area (mm²)		Nominal Dimension (mm)		Tolerance, ± (mm)
	209827				Isaac Erskine		247		Greater Than	Less Than or Equal to	
	Description				Date Drawn		Material		0.00	1.50	0.40
	Rectangle - Solid				31/07/2020		EPDM		1.50	2.50	0.50
	Revision				Approved By		Hardness (Shore A)		2.50	4.00	0.70
	A	Date of Issue		Sheet Scale	Sheet Size	Sheet	Isaac Erskine		4.00	6.30	0.80
		15/02/2022		1:1	A3	1/1	15/02/2022		6.30	10.00	1.00
	Projection				Date of Approval		Colour		10.00	16.00	1.30
	3rd Agl. 				15/02/2022		Black		16.00	25.00	1.60
					Weight (g/m)		311		25.00	40.00	2.00
								40.00	63.00	2.50	
								63.00	100.00	3.20	
								100.00		3.20%	

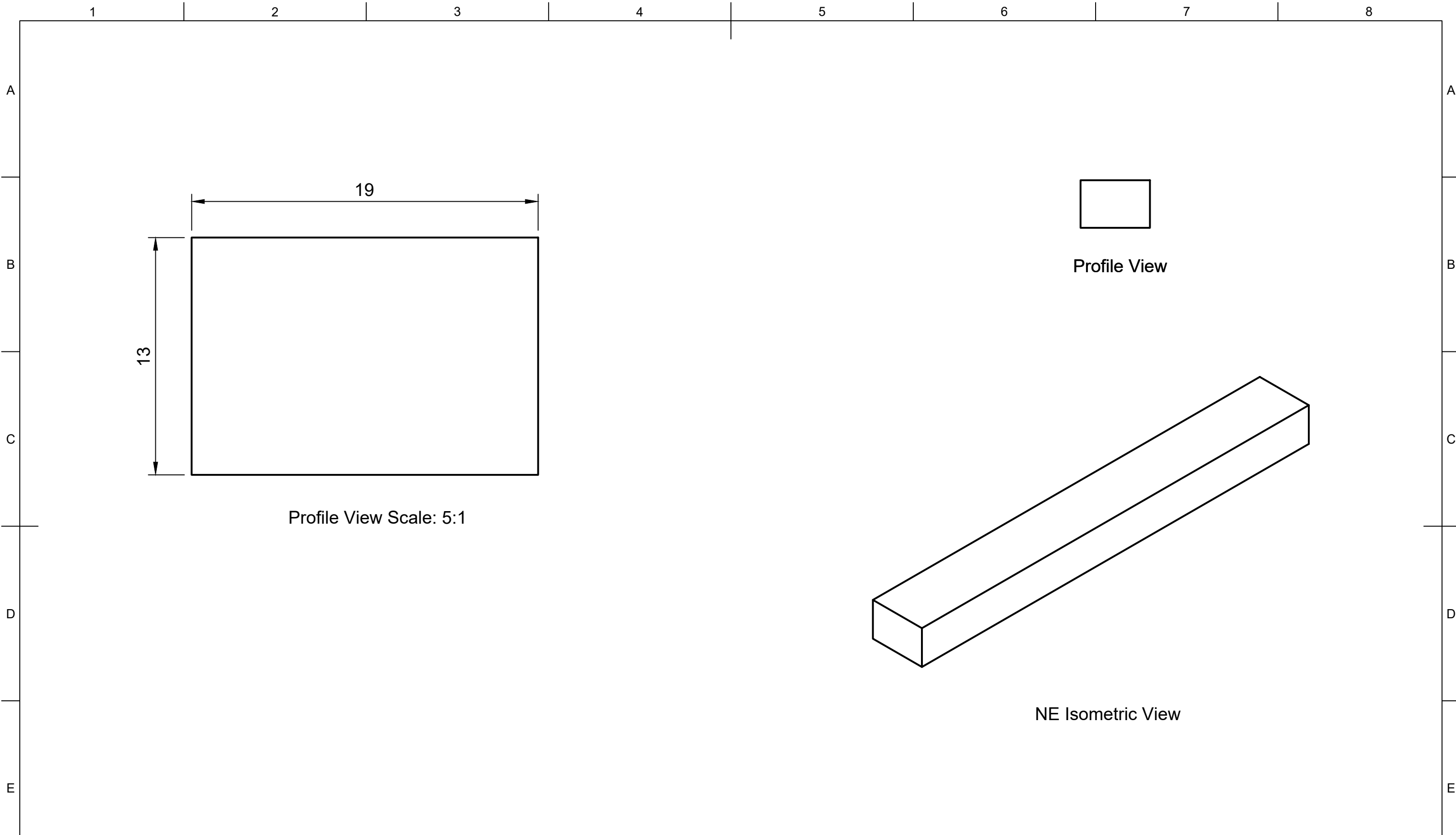

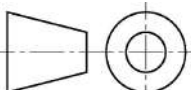
	Part Number				Created By		Cross Sectional Area (mm²)		Nominal Dimension (mm)		Tolerance, ± (mm)
	204883				Isaac Erskine		247		Greater Than	Less Than or Equal to	
	Description				Date Drawn		Material		0.00	1.50	0.40
	Rectangle - Solid				15/02/2022		Neoprene		1.50	2.50	0.50
	Revision				Approved By		Hardness (Shore A)		2.50	4.00	0.70
	A	15/02/2022		Isaac Erskine		70		4.00	6.30	0.80	
	Date of Issue				Date of Approval		Colour		6.30	10.00	1.00
	15/02/2022				15/02/2022		Black		10.00	16.00	1.30
	Sheet Scale				Projection		Weight (g/m)		16.00	25.00	1.60
	1:1				3rd Agl. 		375		25.00	40.00	2.00
Sheet Size								40.00	63.00	2.50	
A3								63.00	100.00	3.20	
Sheet								100.00		3.20%	
1/1											

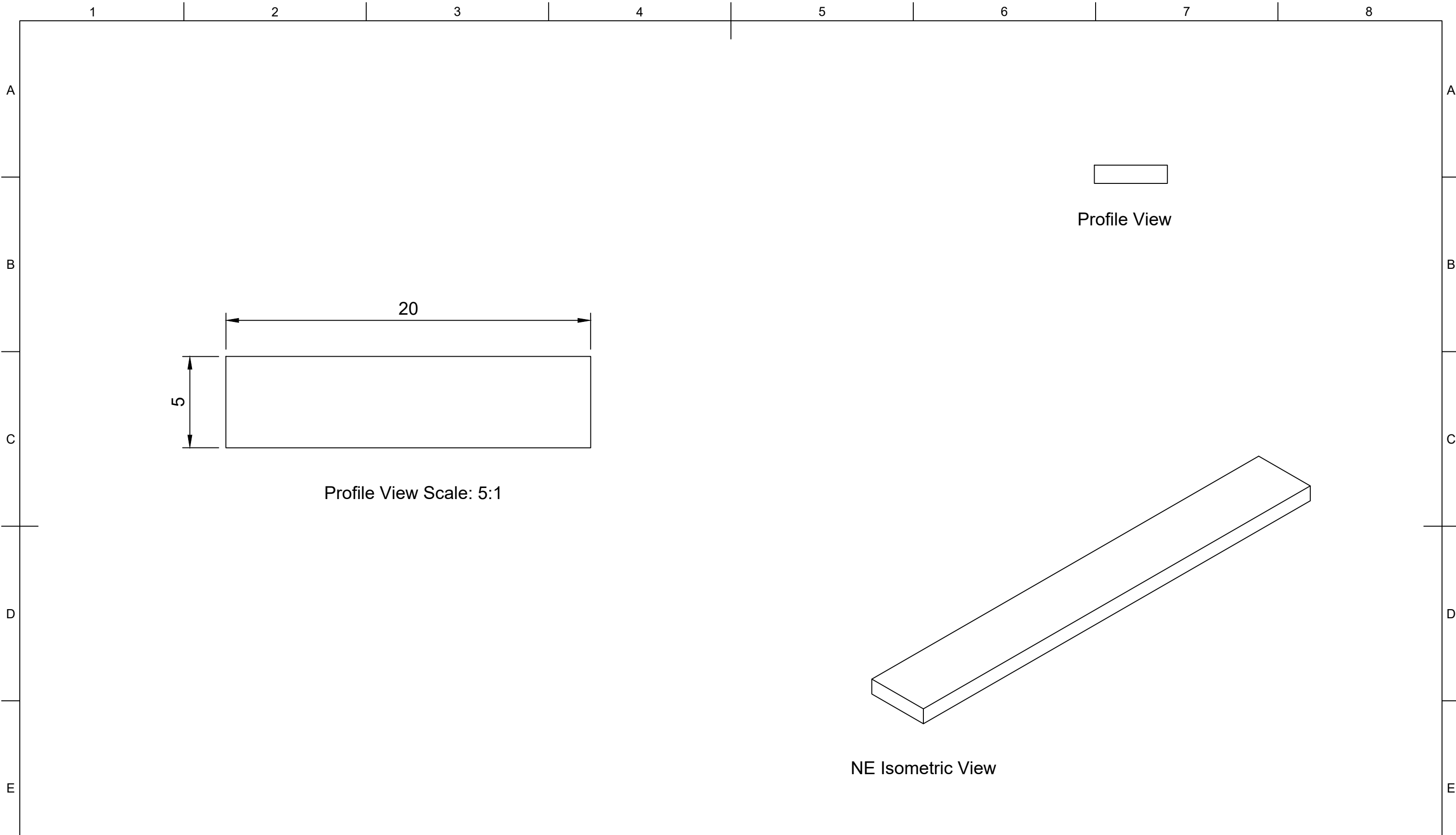

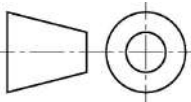
	Part Number				Created By		Cross Sectional Area (mm²)		Nominal Dimension (mm)		Tolerance, ± (mm)
	206752				Isaac Erskine		100		Greater Than	Less Than or Equal to	
	Description				Date Drawn		Material				
	Rectangle - Solid				31/07/2020		EPDM				
					Approved By		Hardness (Shore A)				
					Isaac Erskine		70				
					Date of Approval		Colour				
					15/02/2022		Black				
					Projection		Weight (g/m)				
					3rd Agl. 		126				
Revision	Date of Issue	Sheet Scale	Sheet Size	Sheet							
A	15/02/2022	1:1	A3	1/1							
								25.00	40.00	2.00	
								40.00	63.00	2.50	
								63.00	100.00	3.20	
								100.00		3.20%	

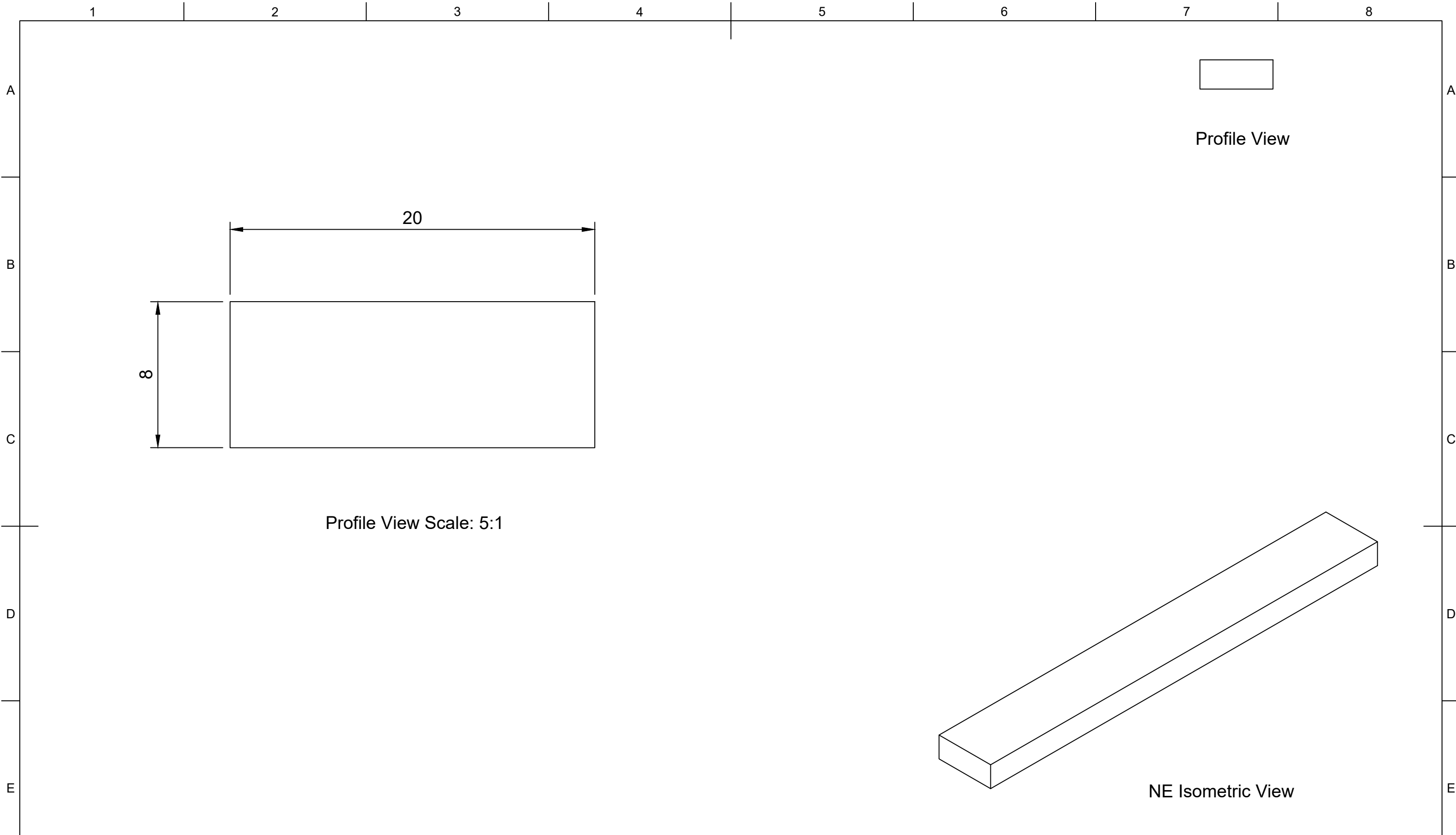

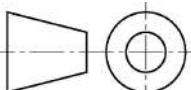
	Part Number				Created By		Cross Sectional Area (mm²)		Nominal Dimension (mm)		Tolerance, ± (mm)
	200886				Isaac Erskine		160		Greater Than	Less Than or Equal to	
	Description				Date Drawn		Material		0.00	1.50	0.40
	Rectangle - Solid				31/07/2020		EPDM		1.50	2.50	0.50
	Revision				Approved By		Hardness (Shore A)		2.50	4.00	0.70
	A	15/02/2022		1:1	A3	1/1	Isaac Erskine		4.00	6.30	0.80
	Date of Issue				Date of Approval		Colour		6.30	10.00	1.00
	Sheet Scale				Projection		Black		10.00	16.00	1.30
	Sheet Size				3rd Agl. 		Weight (g/m)		16.00	25.00	1.60
	Sheet						202		25.00	40.00	2.00
								40.00	63.00	2.50	
								63.00	100.00	3.20	
								100.00		3.20%	

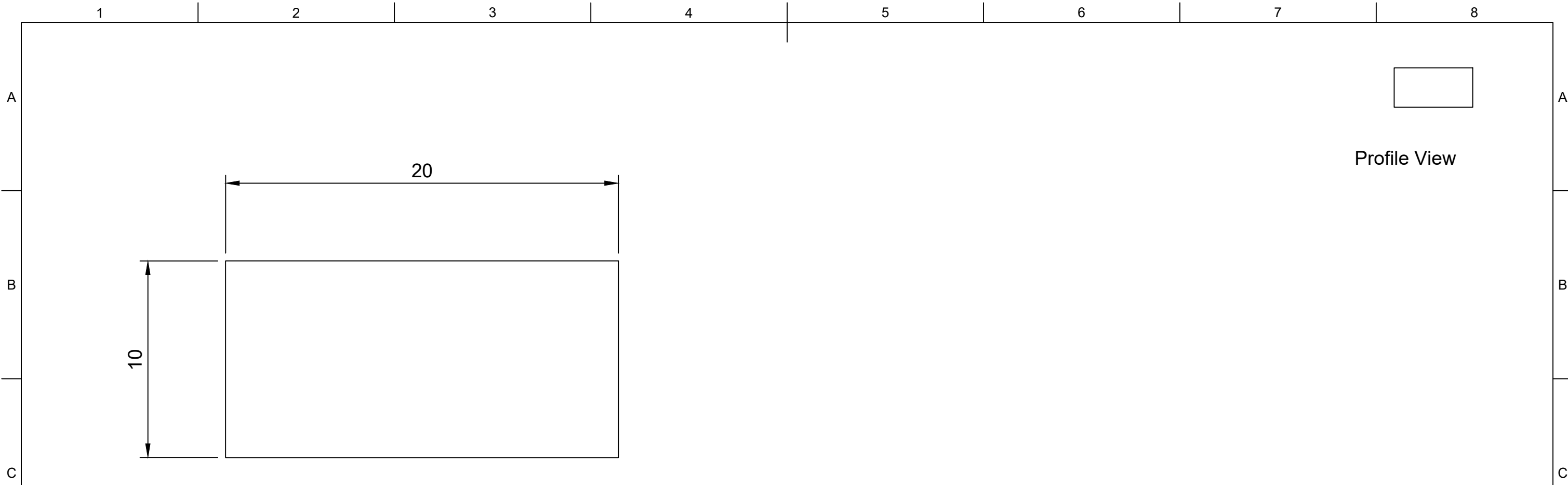

Profile View

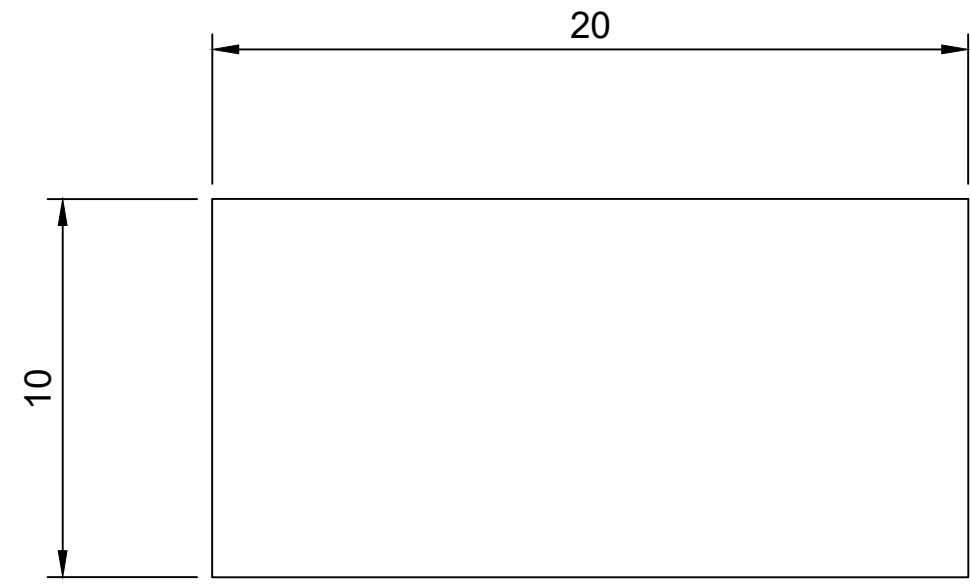

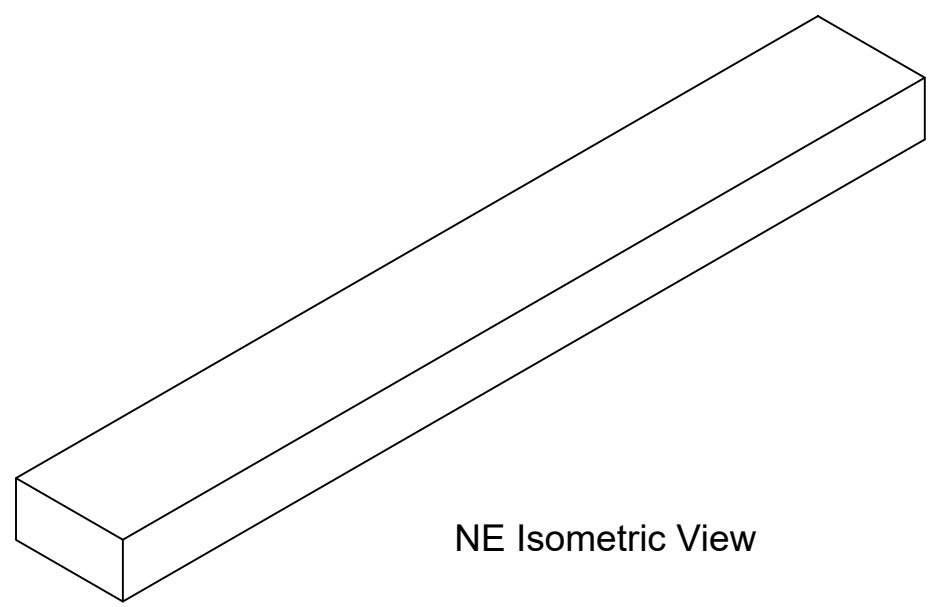

Profile View Scale: 5:1

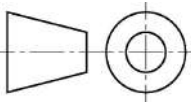

NE Isometric View

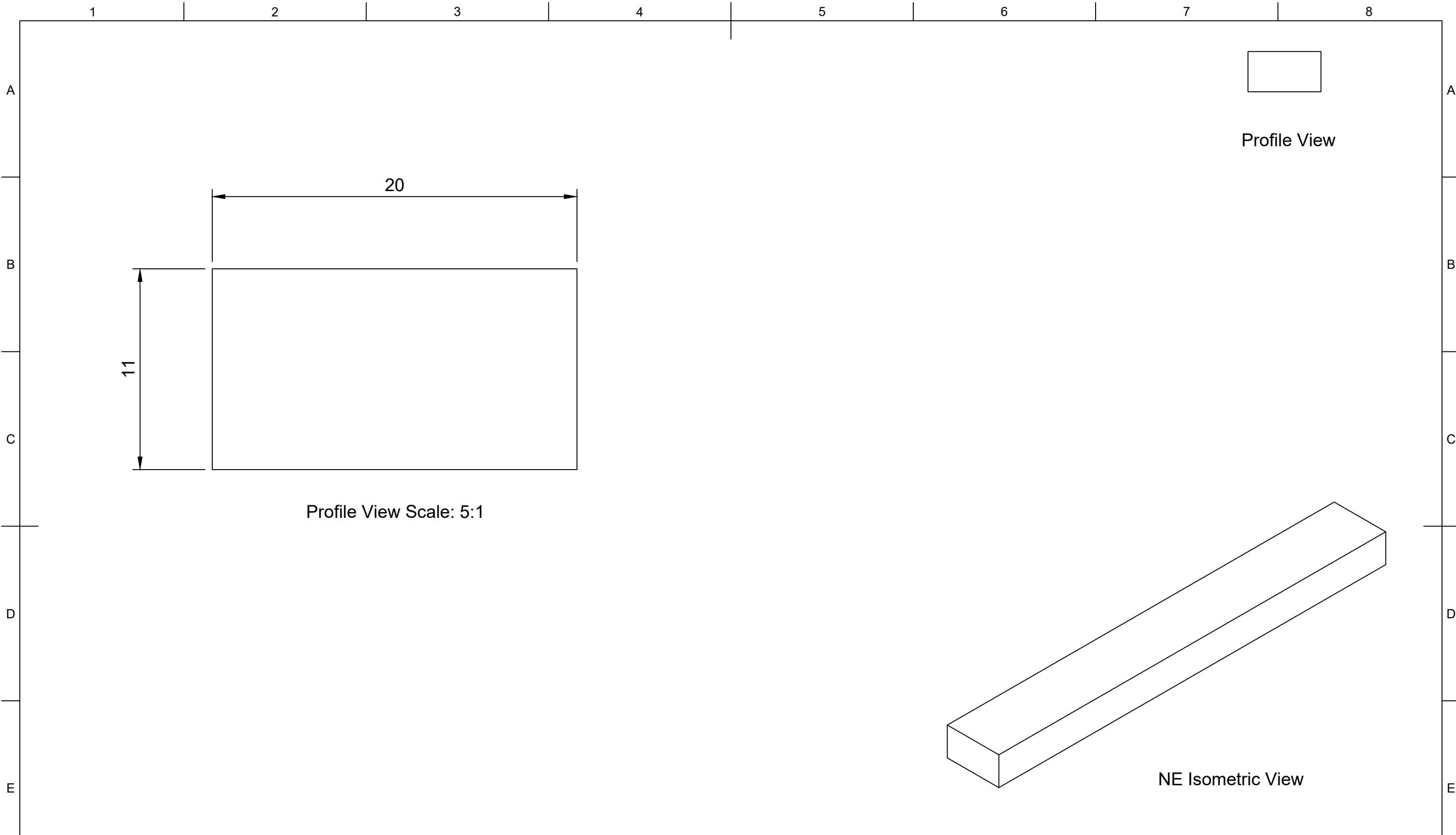
	Part Number				Created By		Cross Sectional Area (mm²)		Nominal Dimension (mm)		Tolerance, ± (mm)	
	208384				Isaac Erskine		200		Greater Than	Less Than or Equal to		
	Description				Date Drawn		Material		0.00	1.50	0.40	
	Rectangle - Solid				31/07/2020		Neoprene		1.50	2.50	0.50	
	Revision				Approved By		Hardness (Shore A)		2.50	4.00	0.70	
	A	15/02/2022		1:1	Isaac Erskine		70		4.00	6.30	0.80	
	Date of Issue		Sheet Scale		Sheet Size		Sheet		Date of Approval		Colour	
	15/02/2022		1:1		A3		1/1		15/02/2022		Black	
	Projection				3rd Agl.		Weight (g/m)		6.30	10.00	1.00	
					3rd Agl.		304		10.00	16.00	1.30	
								16.00	25.00	1.60		
								25.00	40.00	2.00		
								40.00	63.00	2.50		
								63.00	100.00	3.20		
								100.00		3.20%		

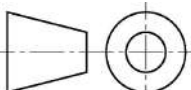

	Part Number				Created By		Cross Sectional Area (mm²)		Nominal Dimension (mm)		Tolerance, ± (mm)
	201891				Isaac Erskine		220		Greater Than	Less Than or Equal to	
	Description				Date Drawn		Material				
	Rectangle - Solid				31/07/2020		EPDM				
	Revision				Approved By		Hardness (Shore A)				
	A	15/02/2022		Isaac Erskine		70					
	Date of Issue		Sheet Scale		Date of Approval		Colour				
	15/02/2022		1:1		15/02/2022		Black				
	Sheet Size		Sheet		Projection		Weight (g/m)				
	A3		1/1		3rd Agl. 		277				
								25.00	40.00	2.00	
								40.00	63.00	2.50	
								63.00	100.00	3.20	
								100.00		3.20%	

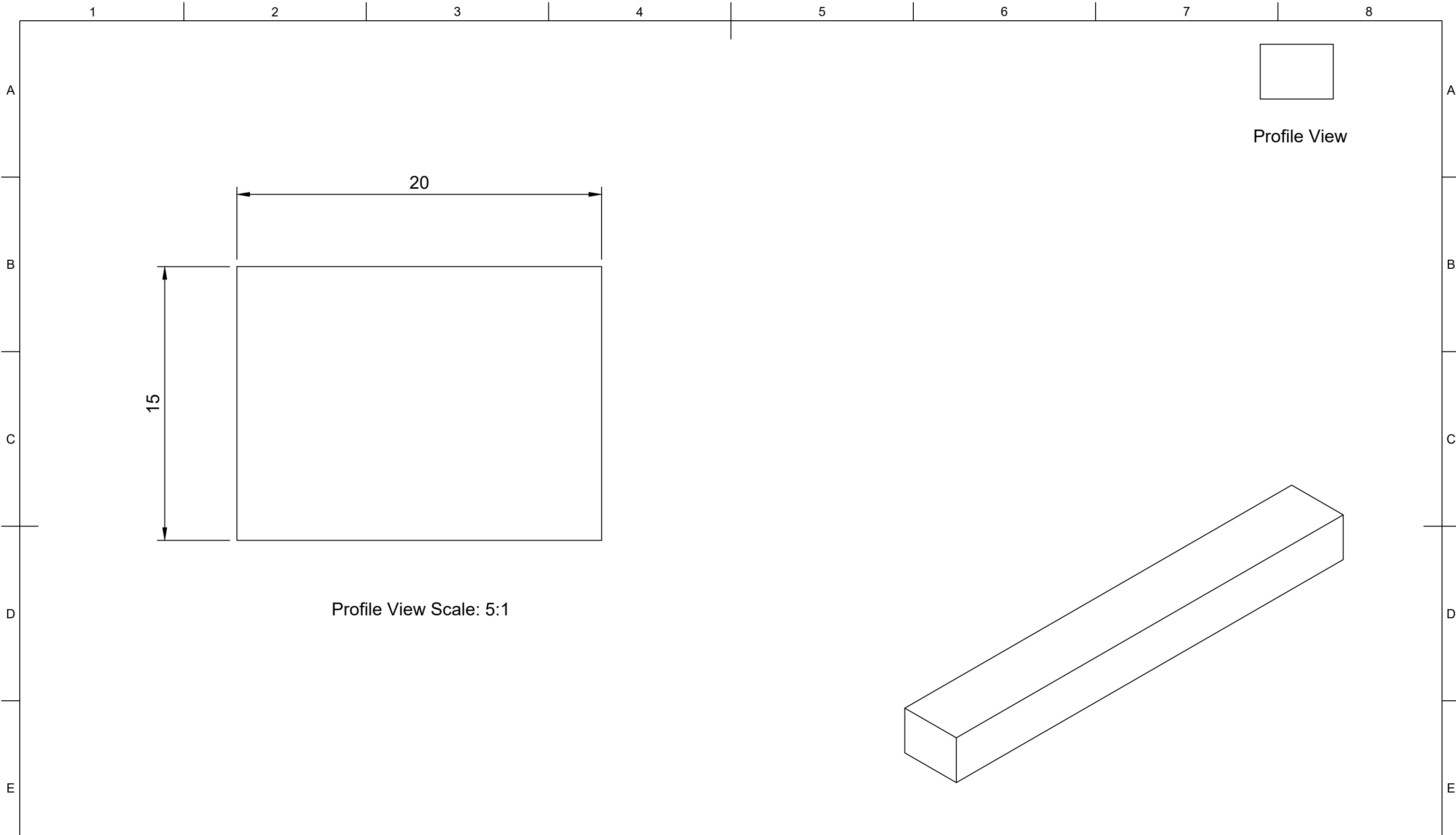

Profile View Scale: 5:1



Part Number 209650					Created By Kev Parkin		Cross Sectional Area (mm ²) 300		Nominal Dimension (mm)		Tolerance, ± (mm)
					Date Drawn 31/07/2020		Material EPDM		Greater Than	Less Than or Equal to	
Description Rectangle - Solid					Approved By Adam Harvey		Hardness (Shore A) 70		0.00	1.50	0.40
					Date of Approval 05/08/2020		Colour Black		1.50	2.50	0.50
Revision A	Date of Issue 05/08/2020	Sheet Scale 1:1	Sheet Size A3	Sheet 1/1	Projection 3rd Agl.	Weight (g/m)		2.50	40.00	2.00	
				378		40.00	63.00	2.50			
						63.00	100.00	3.20			
						100.00		3.20%			

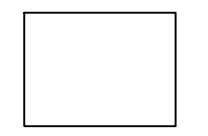
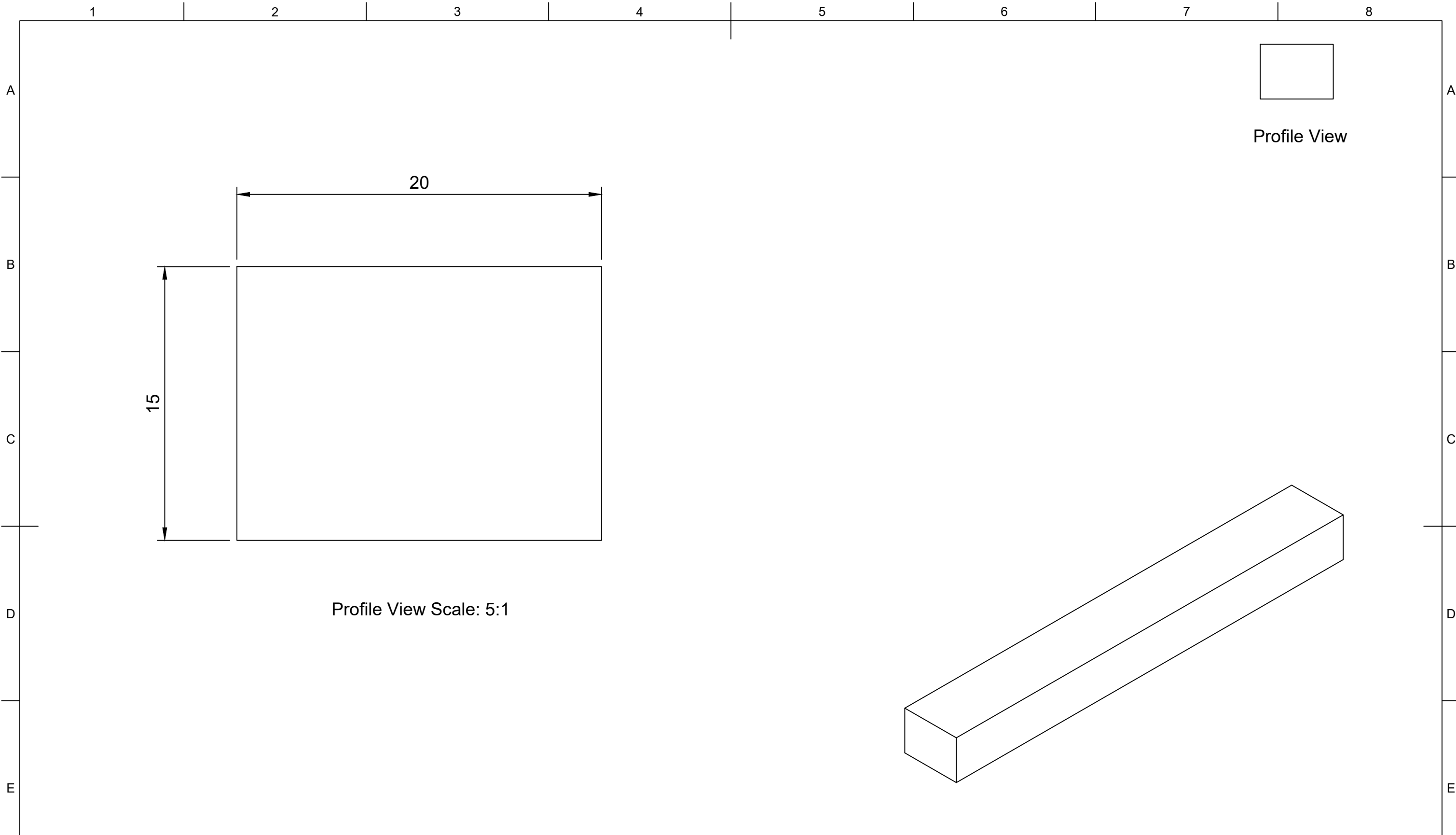

Profile View

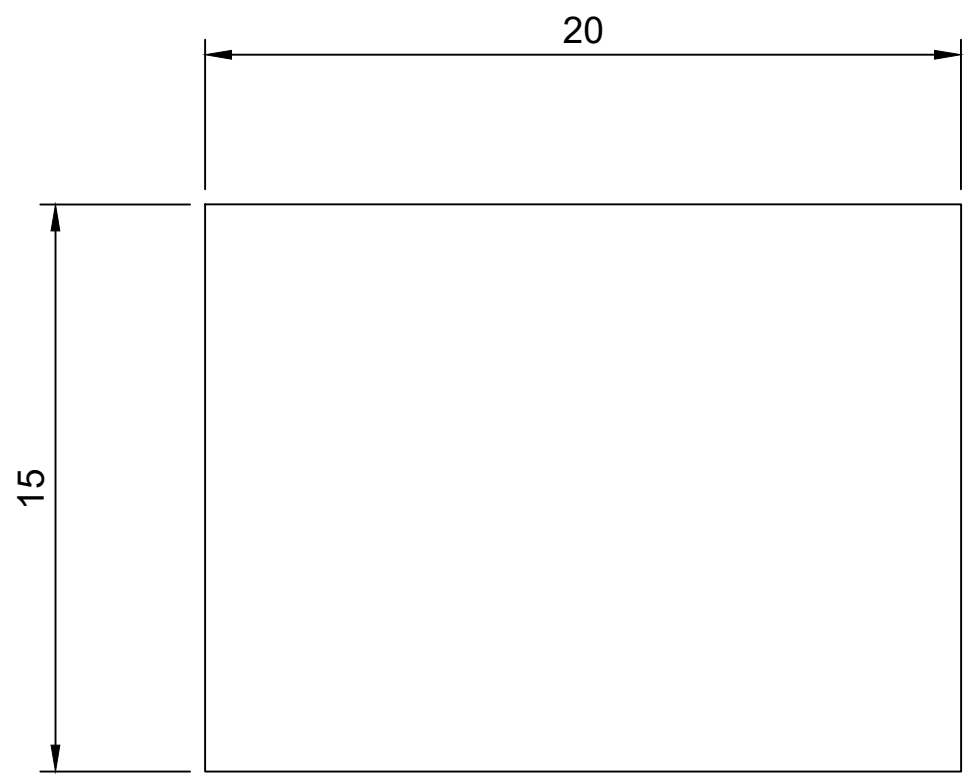

Profile View Scale: 5:1

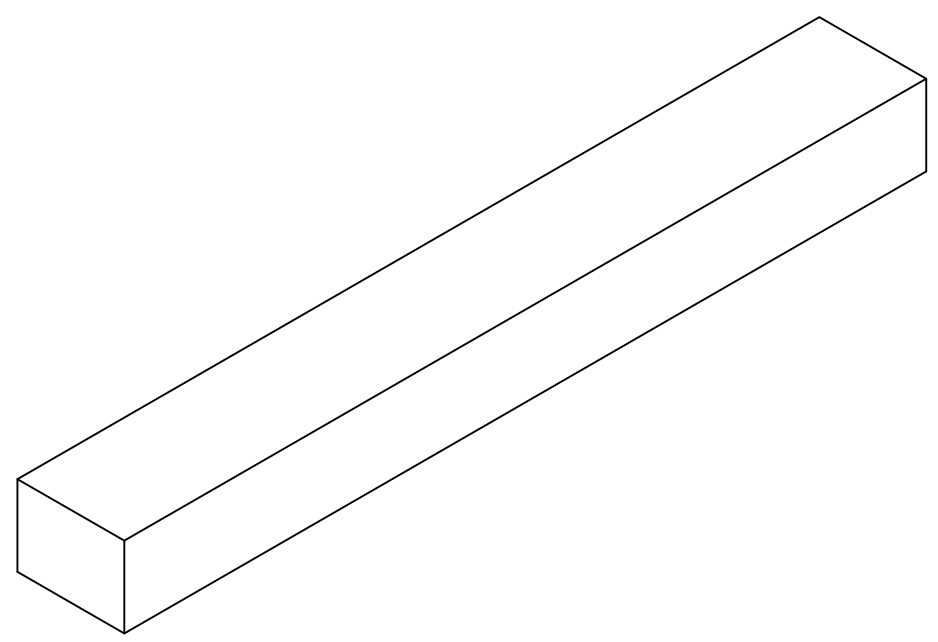

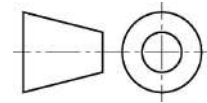
	Part Number				Created By		Cross Sectional Area (mm²)		Nominal Dimension (mm)		Tolerance, ± (mm)	
	203598				Kev Parkin		300		Greater Than	Less Than or Equal to		
	Description				Date Drawn		Material		0.00		0.40	
	Rectangle - Solid				31/07/2020		Nitrile		1.50		0.50	
	Revision				Approved By		Hardness (Shore A)		2.50		0.70	
	A	Date of Issue		Sheet Scale		Adam Harvey		70		4.00		0.80
		05/08/2020		1:1		Date of Approval		Black		6.30		1.00
				A3		05/08/2020		Weight (g/m)		10.00		1.30
				1/1		Projection		363		16.00		1.60
						3rd Agl. 				25.00		2.00
									40.00		2.50	
									63.00		3.20	
									100.00		3.20%	

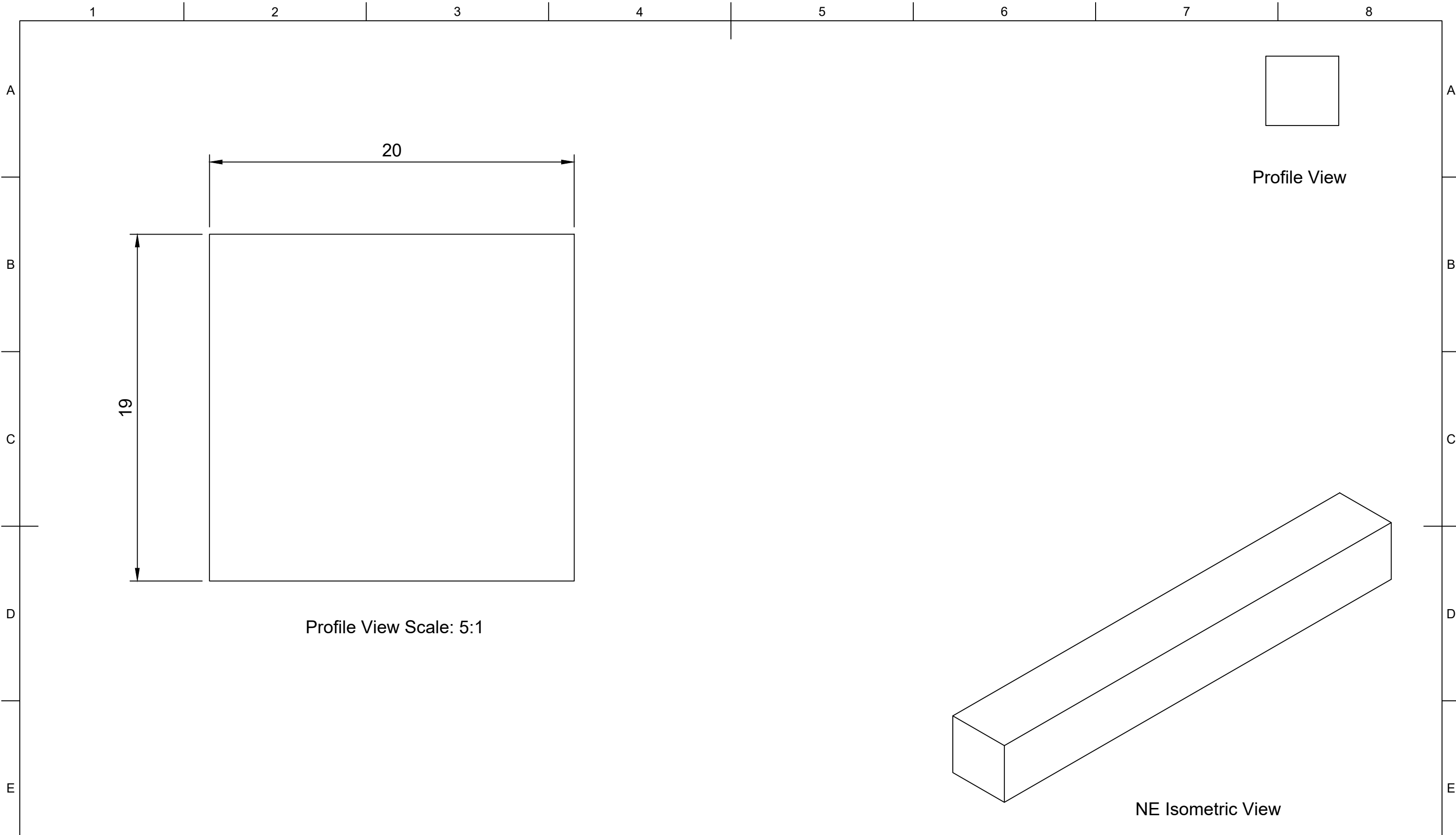

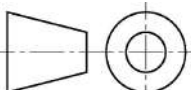
	Part Number				Created By		Cross Sectional Area (mm²)		Nominal Dimension (mm)		Tolerance, ± (mm)
	205029				Isaac Erskine		380		Greater Than	Less Than or Equal to	
	Description				Date Drawn		Material		0.00	1.50	0.40
	Rectangle - Solid				31/07/2020		EPDM		1.50	2.50	0.50
	Revision				Approved By		Hardness (Shore A)		2.50	4.00	0.70
	A	15/02/2022		1:1	A3	1/1	Isaac Erskine		4.00	6.30	0.80
	Date of Issue		Sheet Scale		Sheet Size		Date of Approval		6.30	10.00	1.00
	15/02/2022		1:1		A3		15/02/2022		10.00	16.00	1.30
	Projection		Sheet		Weight (g/m)		3rd Agl.		16.00	25.00	1.60
	3rd Agl.		1/1		479				25.00	40.00	2.00
								40.00	63.00	2.50	
								63.00	100.00	3.20	
								100.00		3.20%	

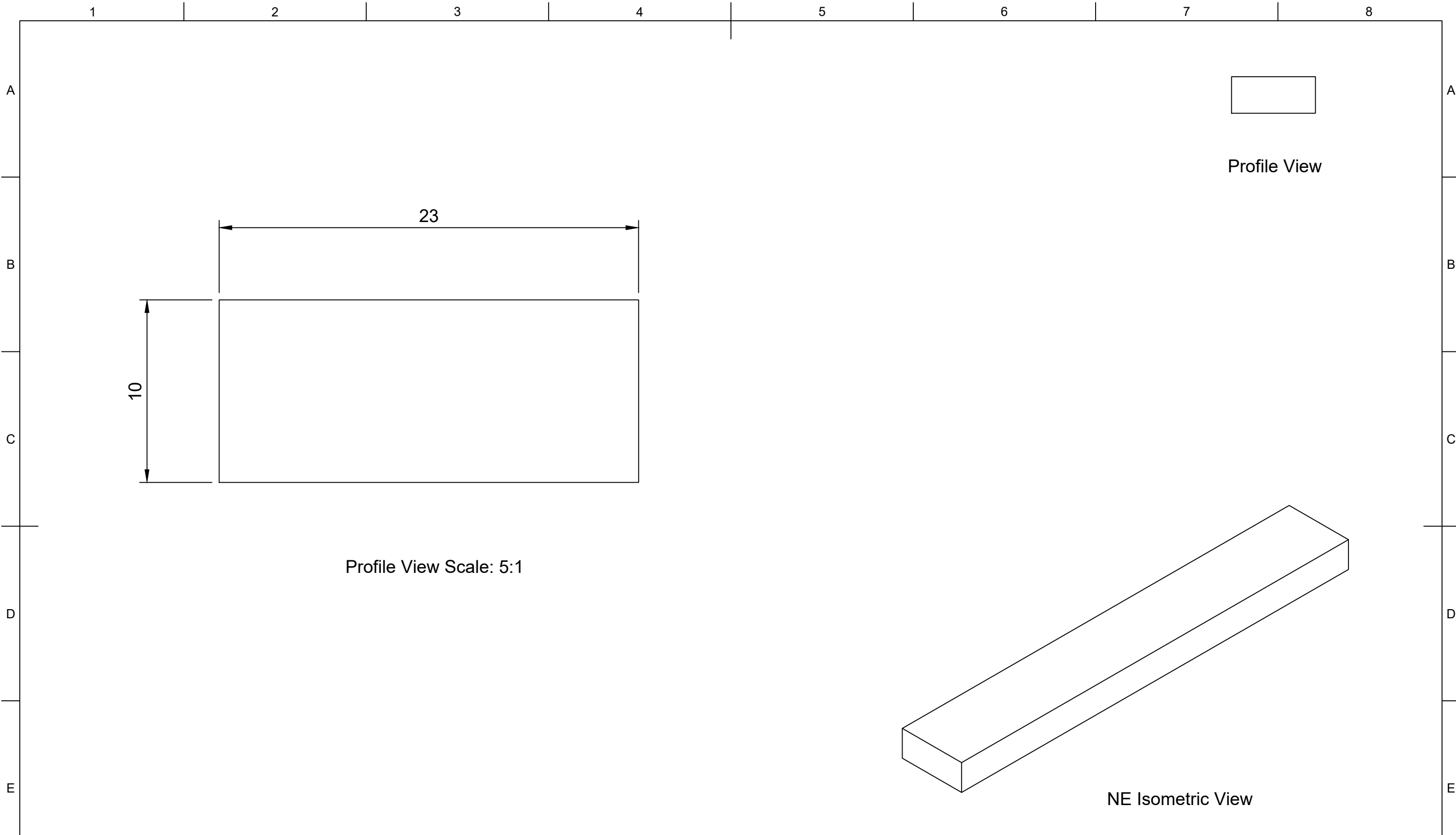

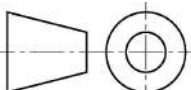
	Part Number				Created By		Cross Sectional Area (mm²)		Nominal Dimension (mm)		Tolerance, ± (mm)
	205611				Isaac Erskine		230		Greater Than	Less Than or Equal to	
	Description				Date Drawn		Material				
	Rectangle - Solid				31/07/2020		Neoprene				
	Revision				Approved By		Hardness (Shore A)				
	A	15/02/2022		Isaac Erskine		70					
	Date of Issue		Sheet Scale		Date of Approval		Colour				
	15/02/2022		1:1		15/02/2022		Black				
	Sheet Size		Sheet		Projection		Weight (g/m)				
	A3		1/1		3rd Agl. 		350				
								25.00	40.00	2.00	
								40.00	63.00	2.50	
								63.00	100.00	3.20	
								100.00		3.20%	

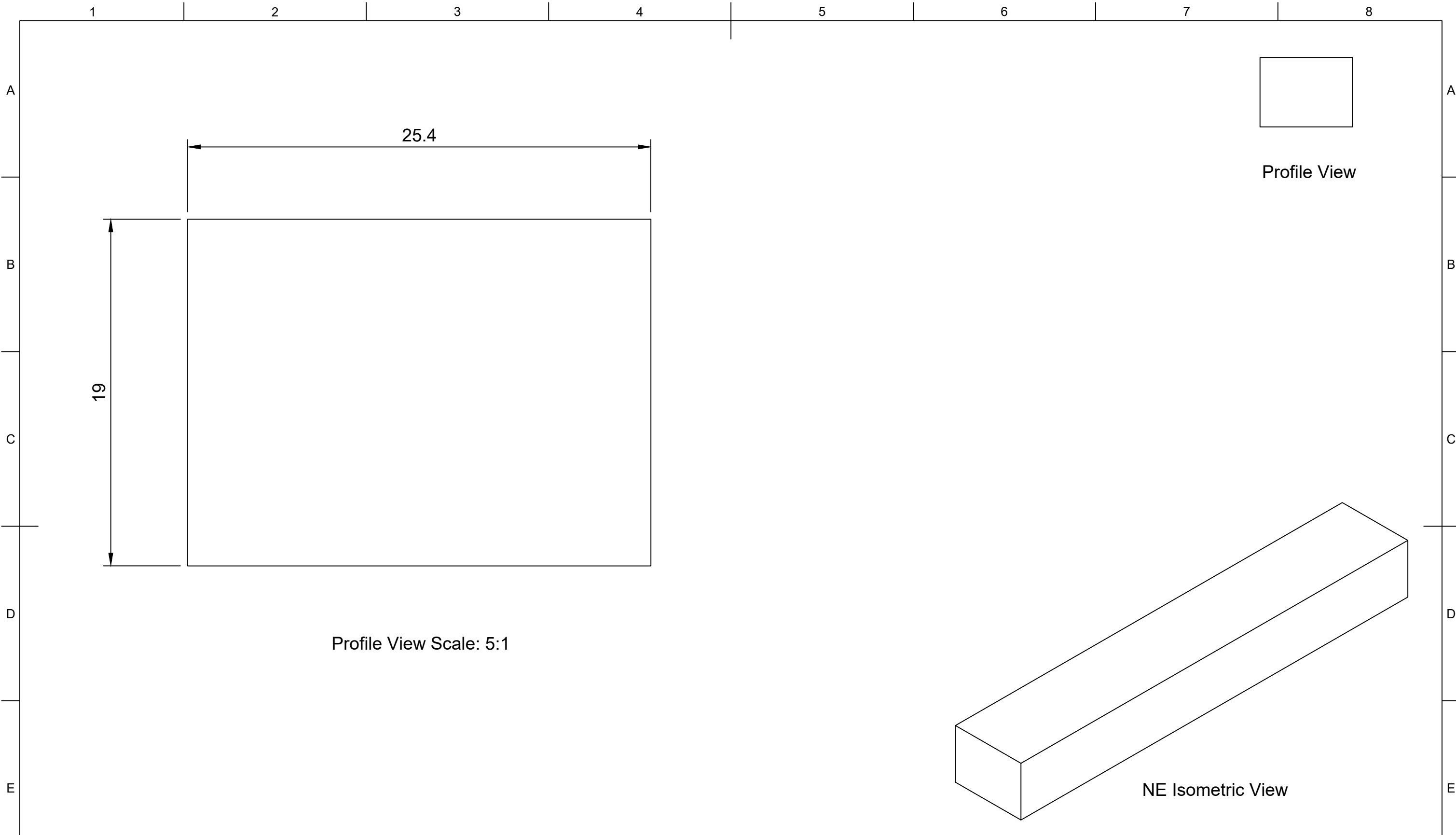

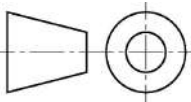
	Part Number				Created By		Cross Sectional Area (mm²)		Nominal Dimension (mm)		Tolerance, ± (mm)
	203137				Isaac Erskine		483		Greater Than	Less Than or Equal to	
	Description				Date Drawn		Material		0.00	1.50	0.40
	Rectangle - Solid				31/07/2020		Nitrile		1.50	2.50	0.50
	Revision				Approved By		Hardness (Shore A)		2.50	4.00	0.70
	A	15/02/2022		1:1	A3	1/1	Isaac Erskine		4.00	6.30	0.80
	Date of Issue				Date of Approval		Colour		6.30	10.00	1.00
	Sheet Scale				Projection		Black		10.00	16.00	1.30
	Sheet Size				3rd Agl. 		Weight (g/m)		16.00	25.00	1.60
	Sheet						584		25.00	40.00	2.00
								40.00	63.00	2.50	
								63.00	100.00	3.20	
								100.00		3.20%	

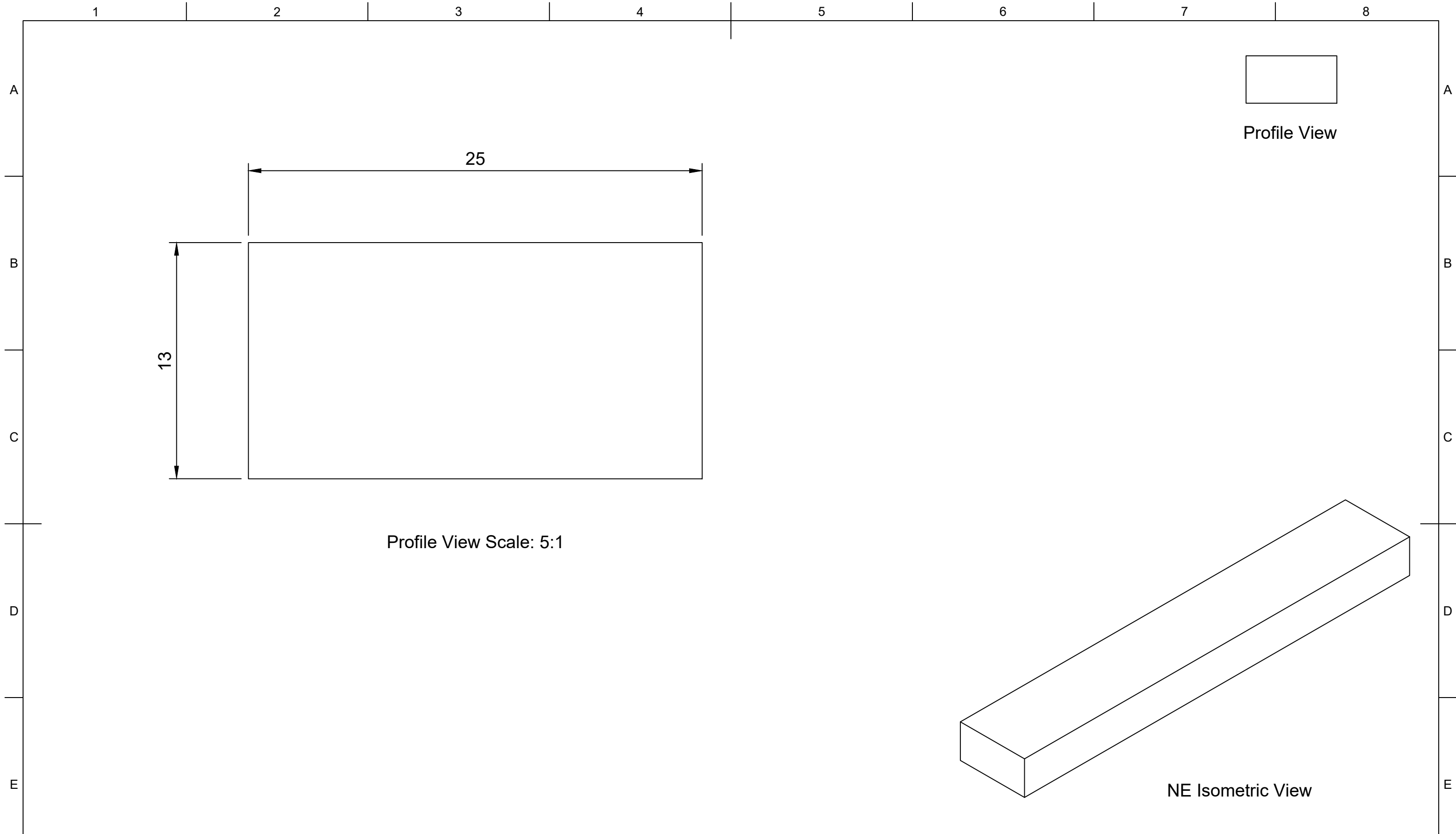

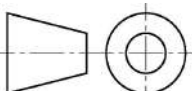
	Part Number				Created By		Cross Sectional Area (mm²)		Nominal Dimension (mm)		Tolerance, ± (mm)
	207838				Isaac Erskine		325		Greater Than	Less Than or Equal to	
	Description				Date Drawn		Material		0.00	1.50	0.40
	Rectangle - Solid				31/07/2020		EPDM		1.50	2.50	0.50
	Revision				Approved By		Hardness (Shore A)		2.50	4.00	0.70
	A	15/02/2022		1:1	A3	1/1	Isaac Erskine		4.00	6.30	0.80
	Date of Issue		Sheet Scale		Sheet Size		Date of Approval		6.30	10.00	1.00
	15/02/2022		1:1		A3		15/02/2022		10.00	16.00	1.30
	Projection				Weight (g/m)		3rd Agl.		16.00	25.00	1.60
					410				25.00	40.00	2.00
								40.00	63.00	2.50	
								63.00	100.00	3.20	
								100.00		3.20%	

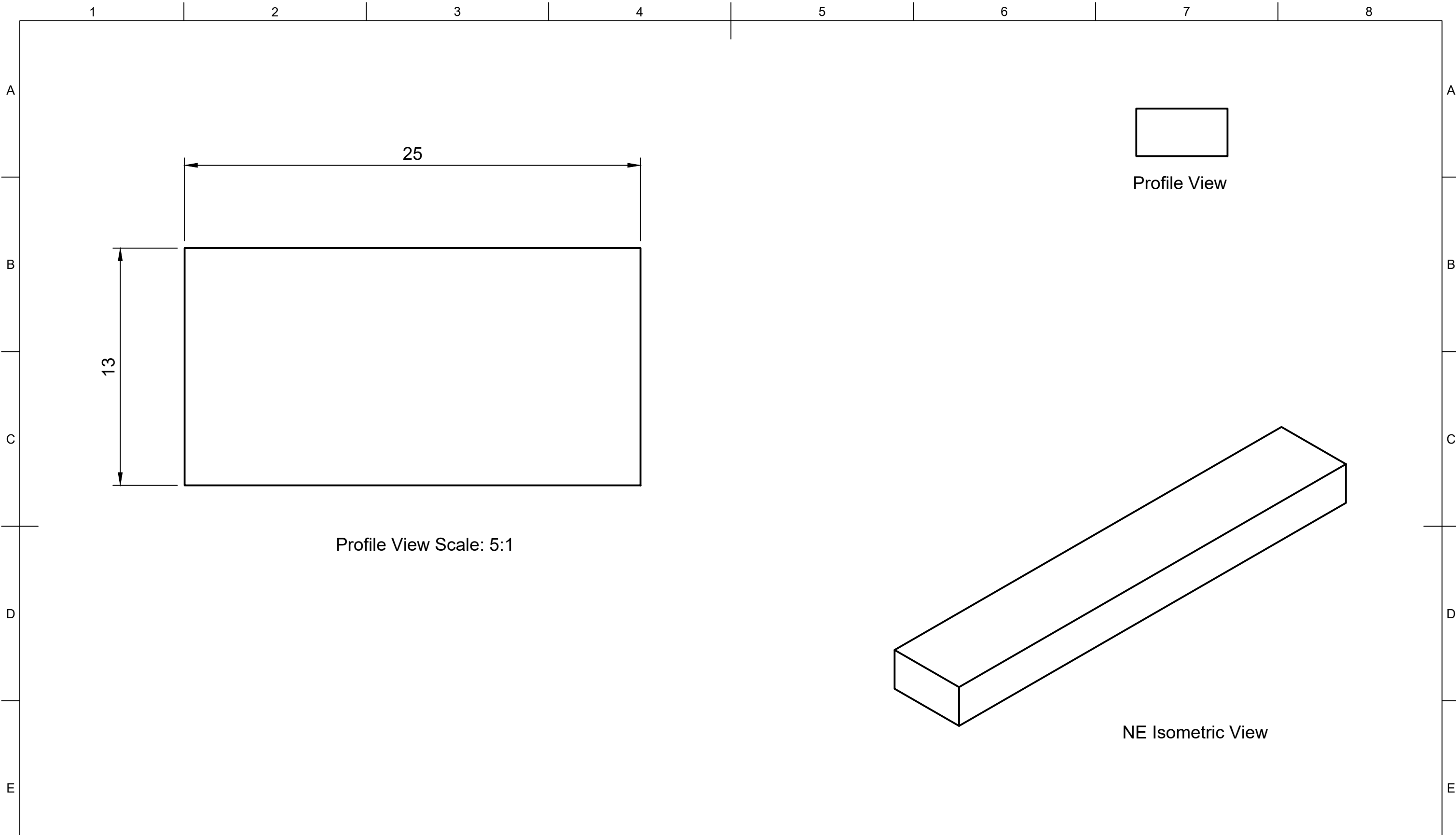

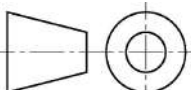
	Part Number				Created By		Cross Sectional Area (mm²)		Nominal Dimension (mm)		Tolerance, ± (mm)
	209169				Isaac Erskine		325		Greater Than	Less Than or Equal to	
	Description				Date Drawn		Material		0.00	1.50	0.40
	Rectangle - Solid				15/02/2022		Neoprene		1.50	2.50	0.50
	Revision				Approved By		Hardness (Shore A)		2.50	4.00	0.70
	A	15/02/2022		Isaac Erskine		70		4.00	6.30	0.80	
	Date of Issue				Date of Approval		Colour		6.30	10.00	1.00
	15/02/2022				15/02/2022		Black		10.00	16.00	1.30
	Sheet Scale				Projection		Weight (g/m)		16.00	25.00	1.60
	1:1				3rd Agl. 		494		25.00	40.00	2.00
Sheet Size								40.00	63.00	2.50	
A3								63.00	100.00	3.20	
Sheet								100.00		3.20%	
1/1											

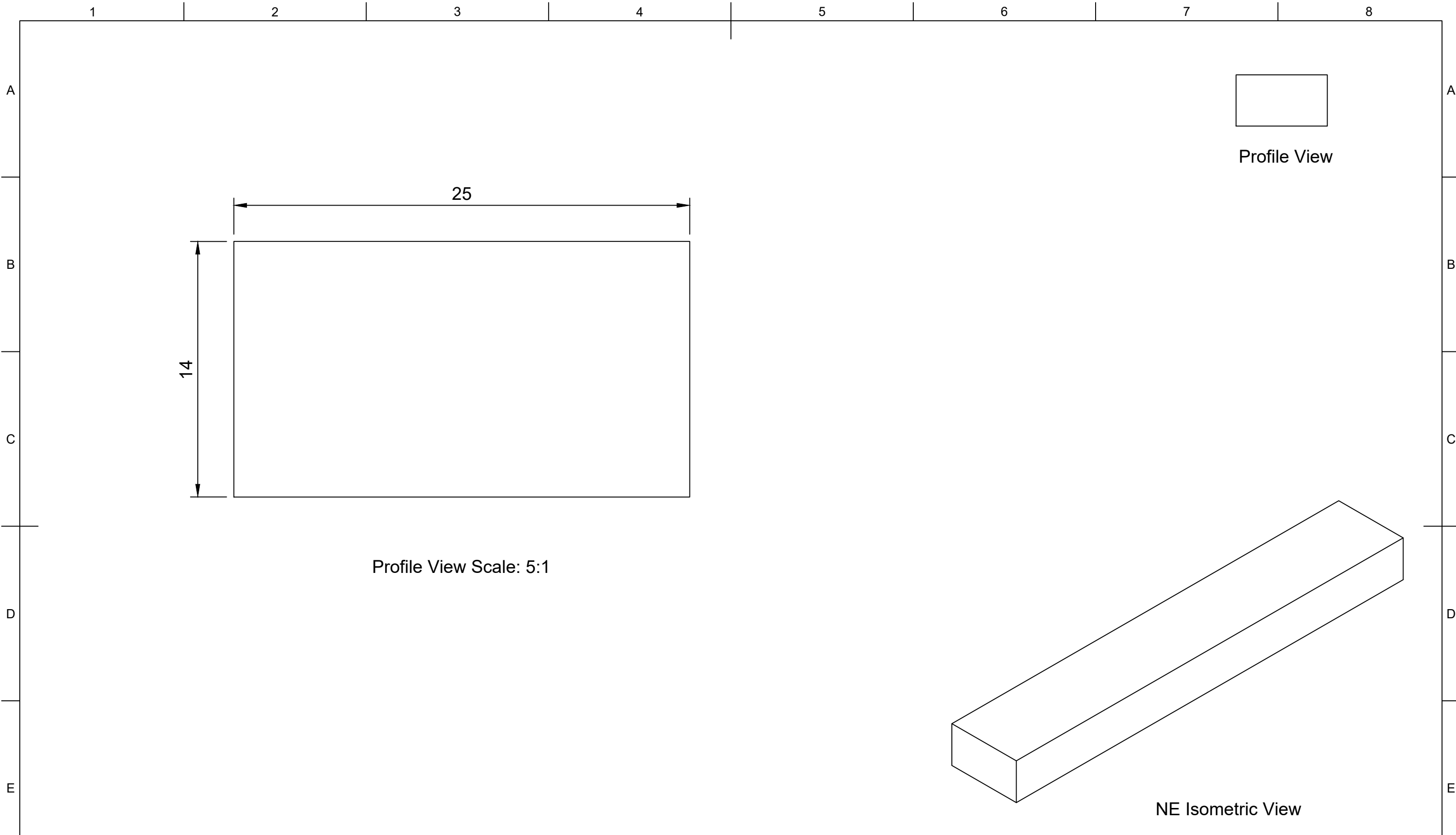

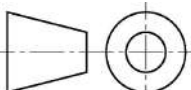
	Part Number				Created By		Cross Sectional Area (mm²)		Nominal Dimension (mm)		Tolerance, ± (mm)
	206995				Isaac Erskine		350		Greater Than	Less Than or Equal to	
	Description				Date Drawn		Material		0.00	1.50	0.40
	Rectangle - Solid				31/07/2020		Nitrile		1.50	2.50	0.50
	Revision				Approved By		Hardness (Shore A)		2.50	4.00	0.70
	A	15/02/2022		1:1	A3	1/1	Isaac Erskine		4.00	6.30	0.80
	Date of Issue				Date of Approval		Colour		6.30	10.00	1.00
	Sheet Scale				Projection		Black		10.00	16.00	1.30
	Sheet Size				3rd Agl. 		Weight (g/m)		16.00	25.00	1.60
	Sheet						424		25.00	40.00	2.00
								40.00	63.00	2.50	
								63.00	100.00	3.20	
								100.00		3.20%	

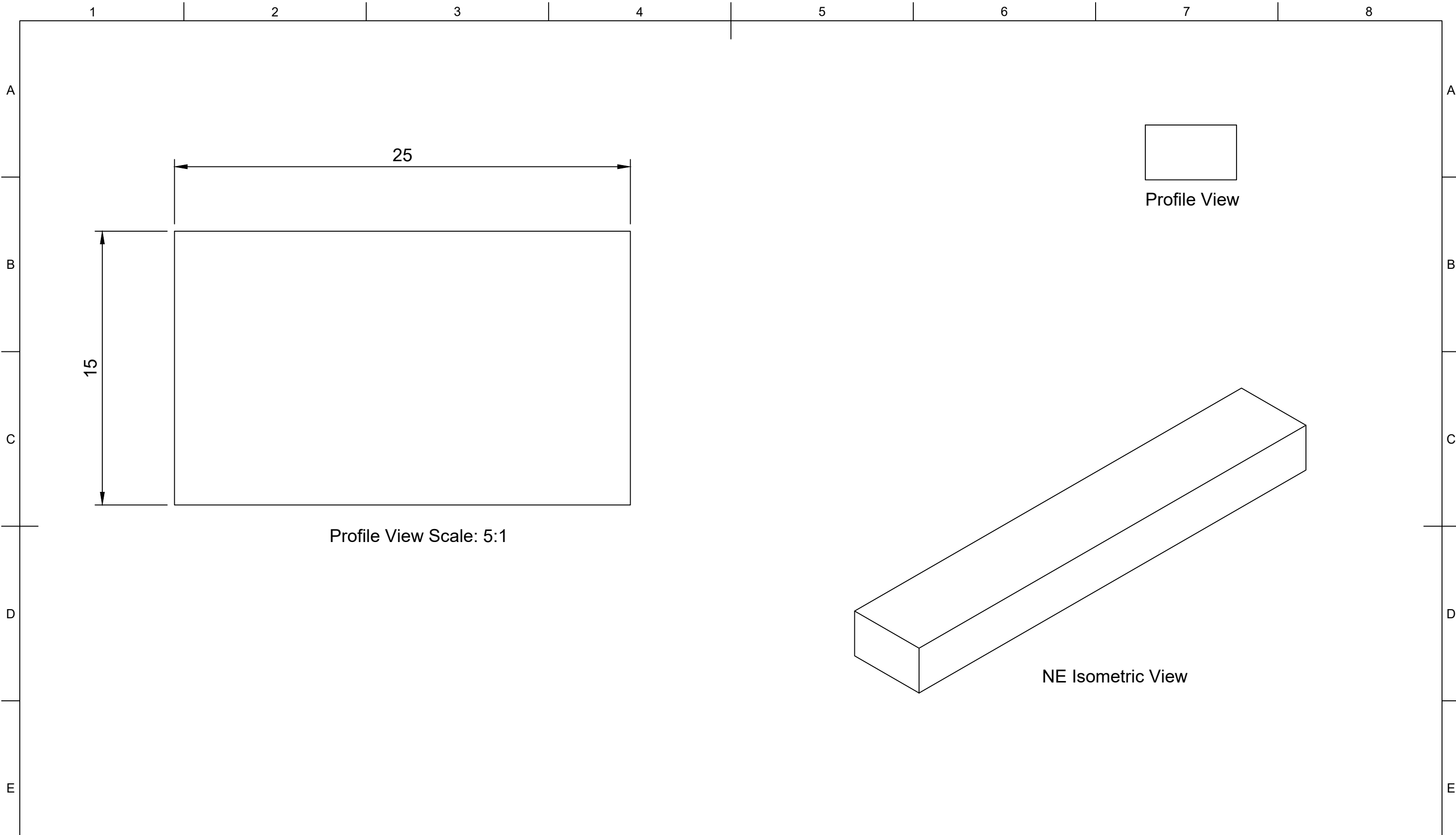

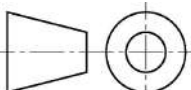
	Part Number				Created By		Cross Sectional Area (mm²)		Nominal Dimension (mm)		Tolerance, ± (mm)
	200149				Isaac Erskine		375		Greater Than	Less Than or Equal to	
	Description				Date Drawn		Material				
	Rectangle - Solid				16/06/2020		EPDM				
	Revision				Approved By		Hardness (Shore A)				
	A	15/02/2022		Isaac Erskine		70					
	Date of Issue		Sheet Scale		Date of Approval		Colour				
	15/02/2022		1:1		15/02/2022		Black				
	Sheet Size		Sheet		Projection		Weight (g/m)				
	A3		1/1		3rd Agl. 		473				
								25.00	40.00	2.00	
								40.00	63.00	2.50	
								63.00	100.00	3.20	
								100.00		3.20%	

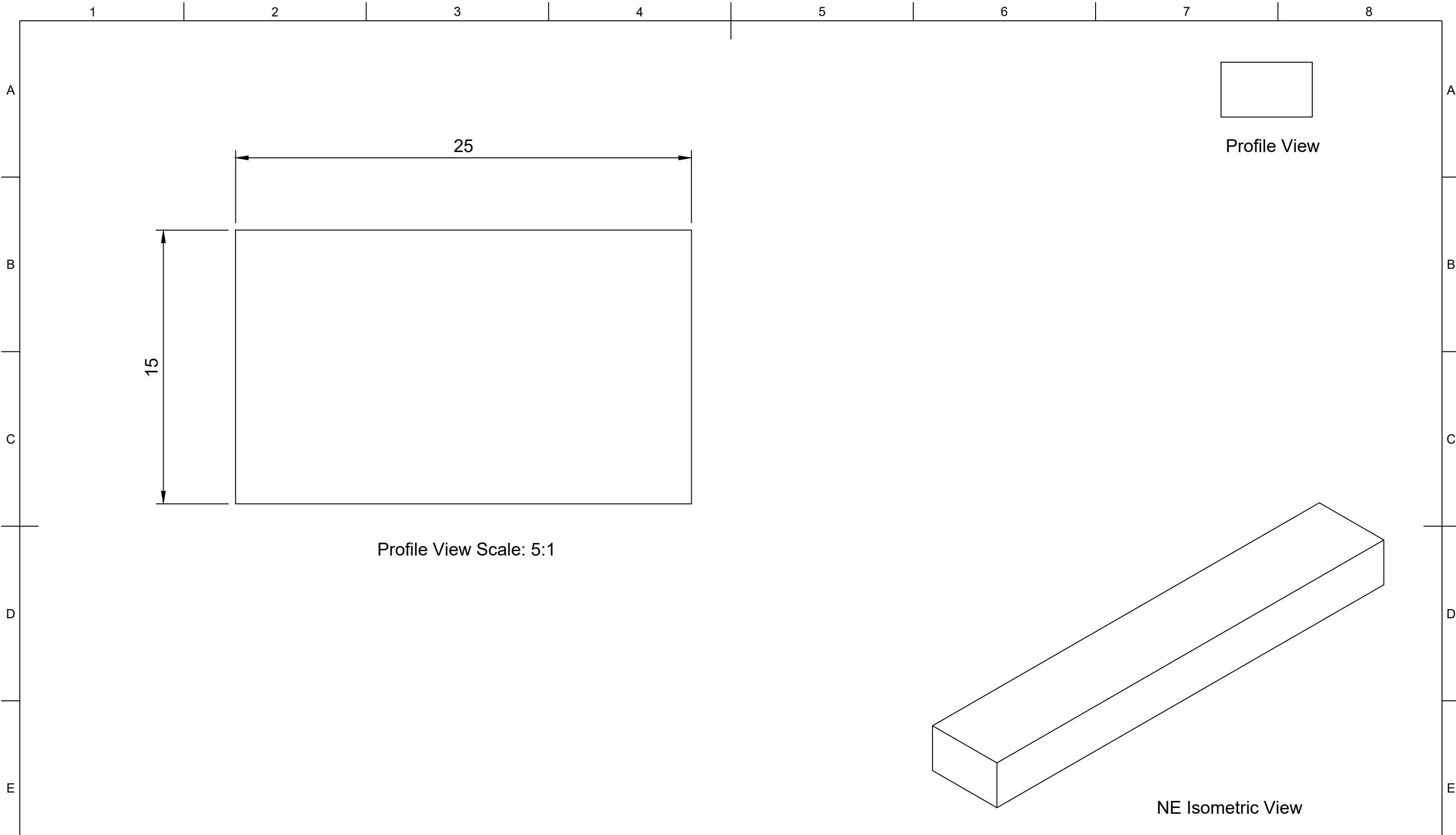

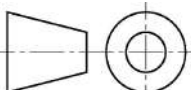
	Part Number				Created By		Cross Sectional Area (mm²)		Nominal Dimension (mm)		Tolerance, ± (mm)
	206325				Isaac Erskine		375		Greater Than	Less Than or Equal to	
	Description				Date Drawn		Material		0.00	1.50	0.40
	Rectangle - Solid				31/07/2020		Neoprene		1.50	2.50	0.50
	Revision				Approved By		Hardness (Shore A)		2.50	4.00	0.70
	A	15/02/2022		1:1	A3	1/1	Isaac Erskine		4.00	6.30	0.80
	Date of Issue				Date of Approval		Colour		6.30	10.00	1.00
	Sheet Scale				Projection		Black		10.00	16.00	1.30
	Sheet Size				3rd Agl. 		570		16.00	25.00	1.60
	Sheet								25.00	40.00	2.00
								40.00	63.00	2.50	
								63.00	100.00	3.20	
								100.00		3.20%	

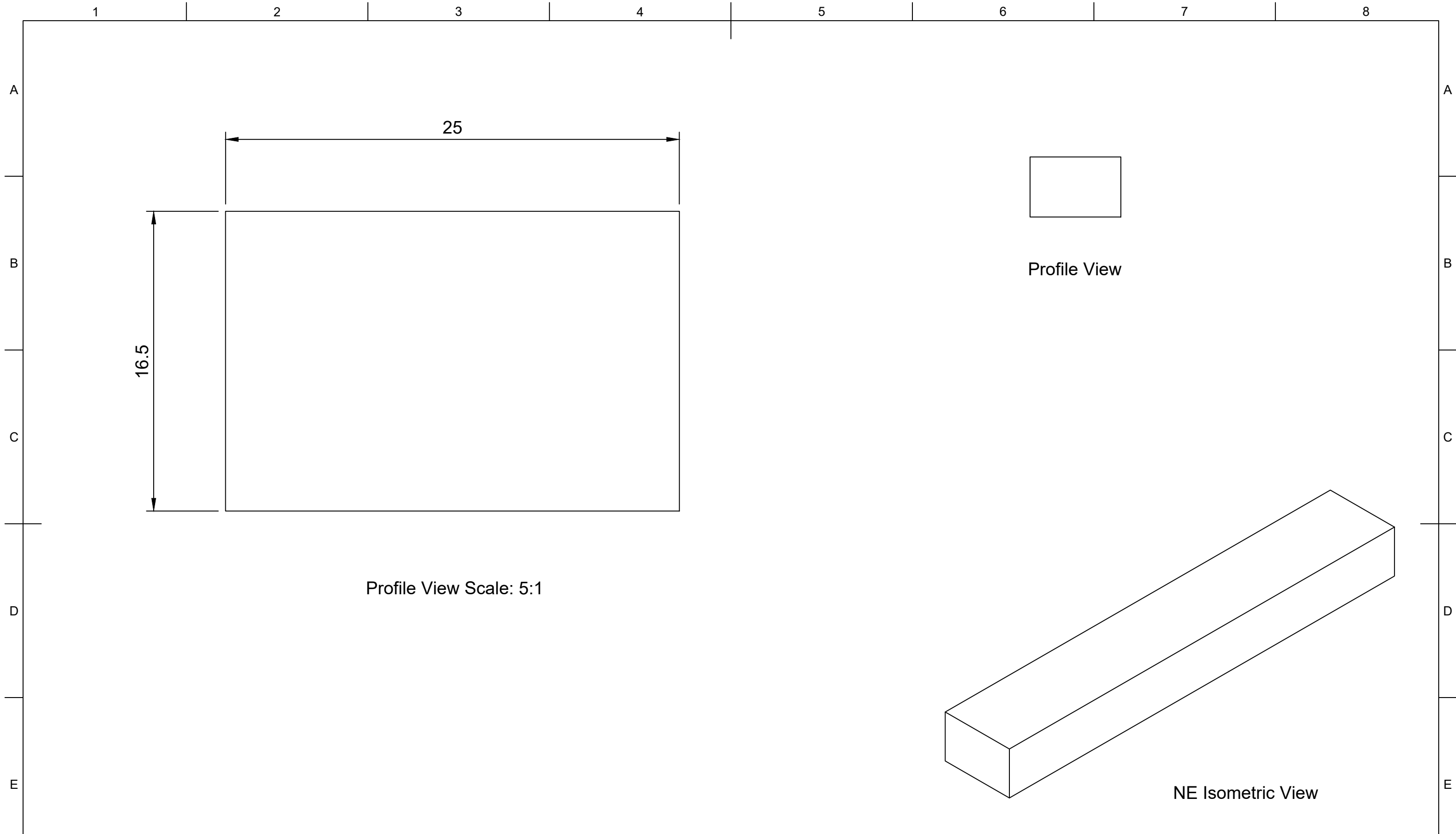

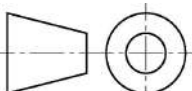
	Part Number				Created By		Cross Sectional Area (mm²)		Nominal Dimension (mm)		Tolerance, ± (mm)
	201515				Isaac Erskine		413		Greater Than	Less Than or Equal to	
	Description				Date Drawn		Material				
	Rectangle - Solid				01/08/2020		Nitrile				
	Revision				Approved By		Hardness (Shore A)				
	A	15/02/2022		Isaac Erskine		70					
	Date of Issue		Sheet Scale		Date of Approval		Colour				
	15/02/2022		1:1		15/02/2022		Black				
	Sheet Size		Sheet		Projection		Weight (g/m)				
	A3		1/1		3rd Agl. 		500				
								25.00	40.00	2.00	
								40.00	63.00	2.50	
								63.00	100.00	3.20	
								100.00		3.20%	

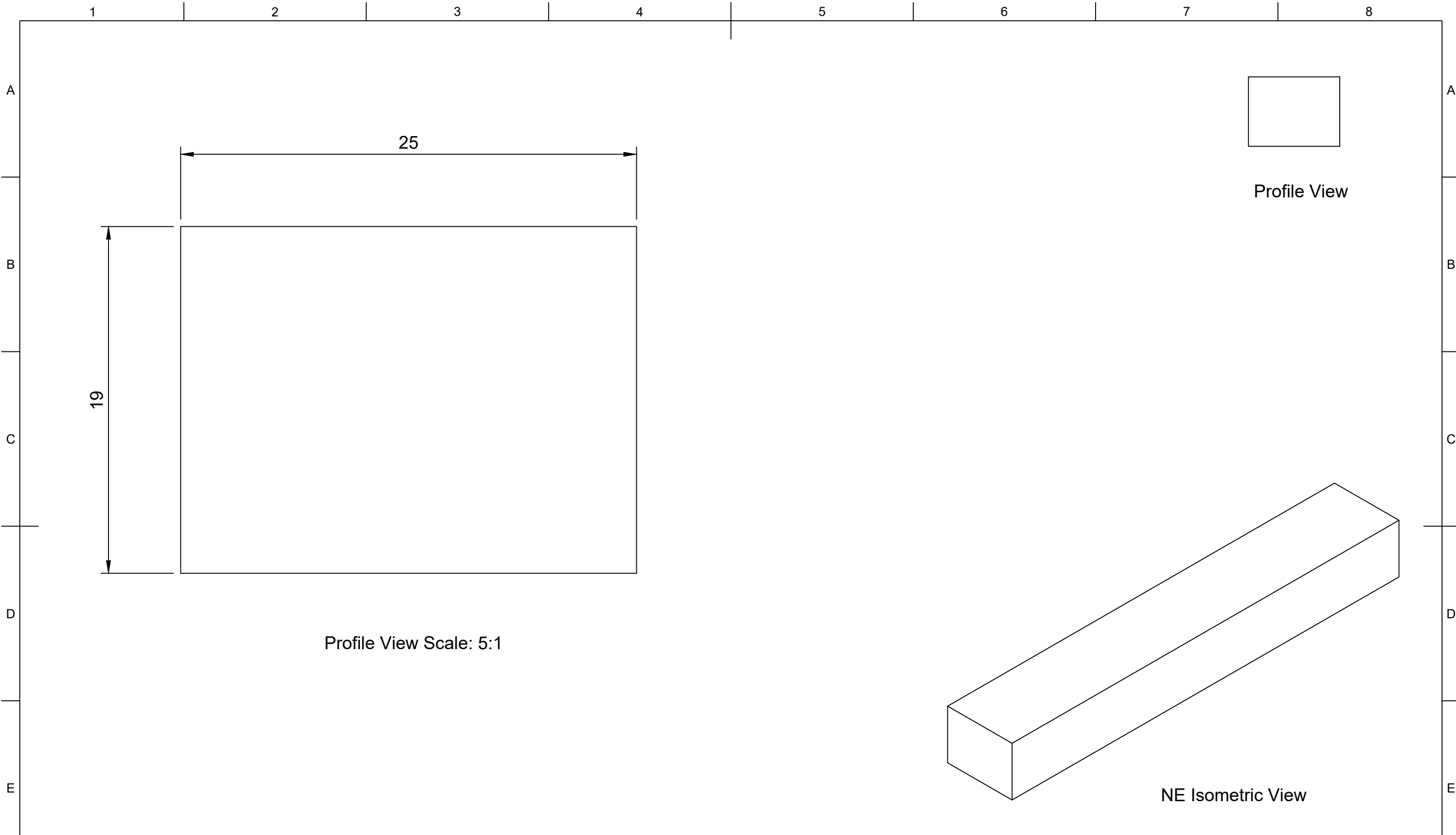

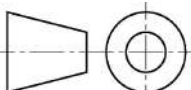
	Part Number				Created By		Cross Sectional Area (mm²)		Nominal Dimension (mm)		Tolerance, ± (mm)
	200877				Isaac Erskine		475		Greater Than	Less Than or Equal to	
	Description				Date Drawn		Material				
	Rectangle - Solid				01/08/2020		EPDM				
					Approved By		Hardness (Shore A)				
					Isaac Erskine		70				
					Date of Approval		Colour				
					15/02/2022		Black				
					Projection		Weight (g/m)				
					3rd Agl. 		599				
Revision	Date of Issue	Sheet Scale	Sheet Size	Sheet							
A	15/02/2022	1:1	A3	1/1							
								25.00	40.00	2.00	
								40.00	63.00	2.50	
								63.00	100.00	3.20	
								100.00		3.20%	

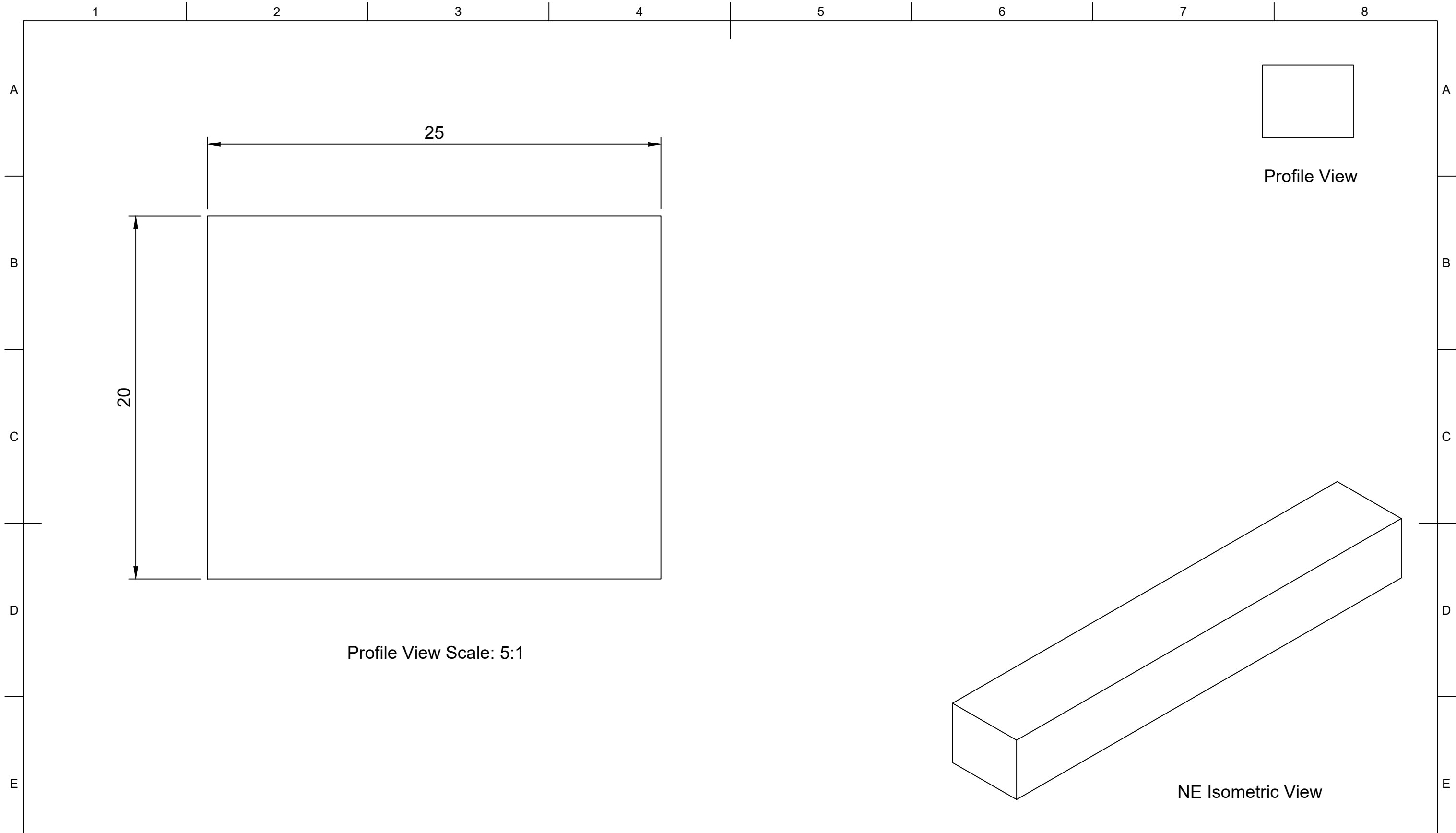

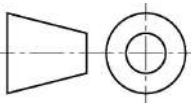
	Part Number				Created By		Cross Sectional Area (mm²)		Nominal Dimension (mm)		Tolerance, ± (mm)
	207524				Isaac Erskine		500		Greater Than	Less Than or Equal to	
	Description				Date Drawn		Material		0.00	1.50	0.40
	Rectangle - Solid				01/08/2020		Neoprene		1.50	2.50	0.50
	Revision				Approved By		Hardness (Shore A)		2.50	4.00	0.70
	A	Date of Issue			Isaac Erskine		70		4.00	6.30	0.80
		15/02/2022			Date of Approval		Colour		6.30	10.00	1.00
		1:1			15/02/2022		Black		10.00	16.00	1.30
		A3			Projection		Weight (g/m)		16.00	25.00	1.60
		1/1			3rd Agl. 		760		25.00	40.00	2.00
								40.00	63.00	2.50	
								63.00	100.00	3.20	
								100.00		3.20%	

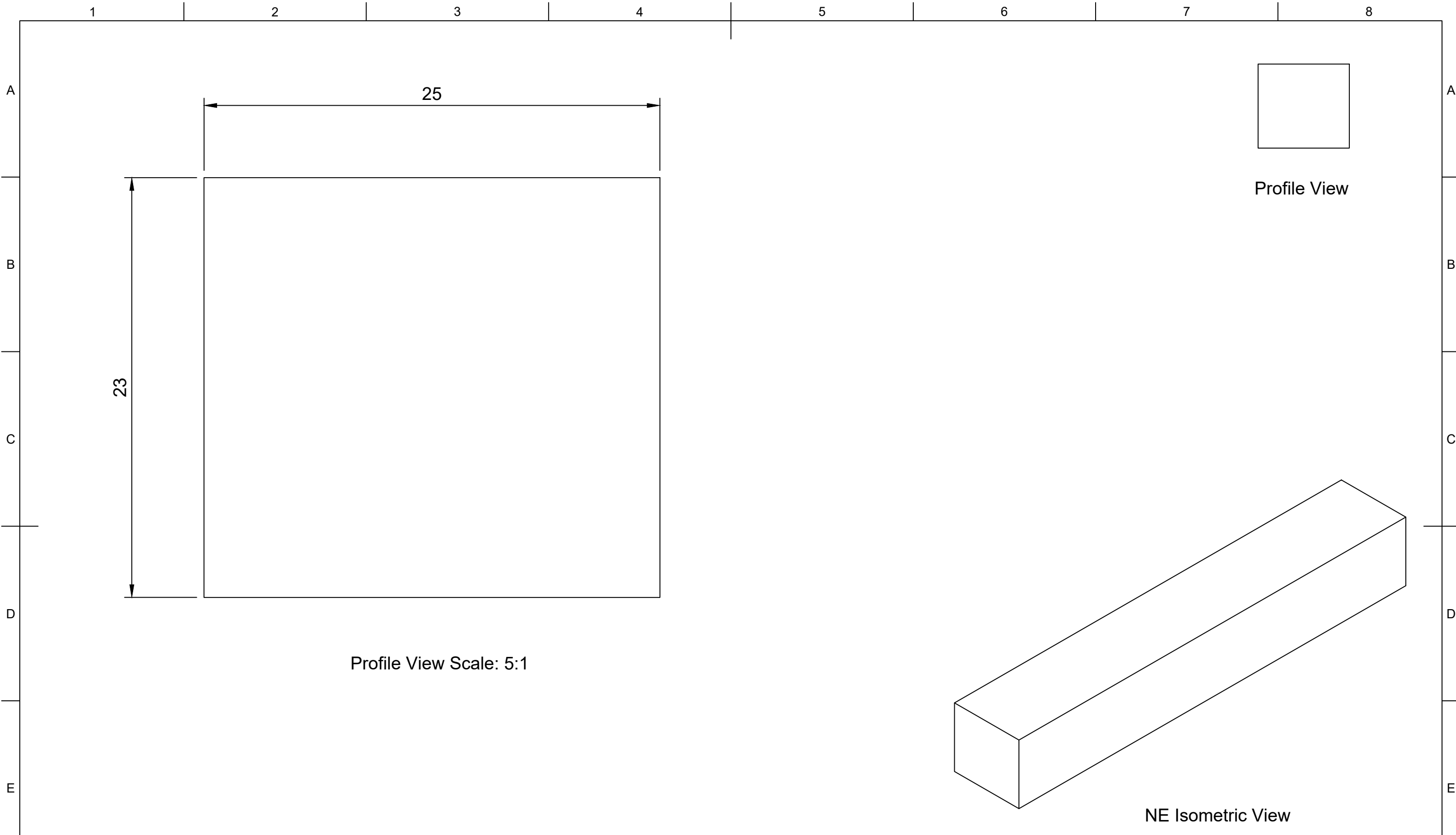

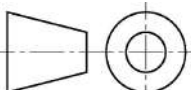
	Part Number				Created By		Cross Sectional Area (mm²)		Nominal Dimension (mm)		Tolerance, ± (mm)
	206840				Isaac Erskine		575		Greater Than	Less Than or Equal to	
	Description				Date Drawn		Material				
	Rectangle - Solid				01/08/2020		EPDM				
					Approved By		Hardness (Shore A)				
					Isaac Erskine		70				
					Date of Approval		Colour				
					15/02/2022		Black				
					Projection		Weight (g/m)				
					3rd Agl. 		725				
Revision	Date of Issue	Sheet Scale	Sheet Size	Sheet							
A	15/02/2022	1:1	A3	1/1							
								25.00	40.00	2.00	
								40.00	63.00	2.50	
								63.00	100.00	3.20	
								100.00		3.20%	

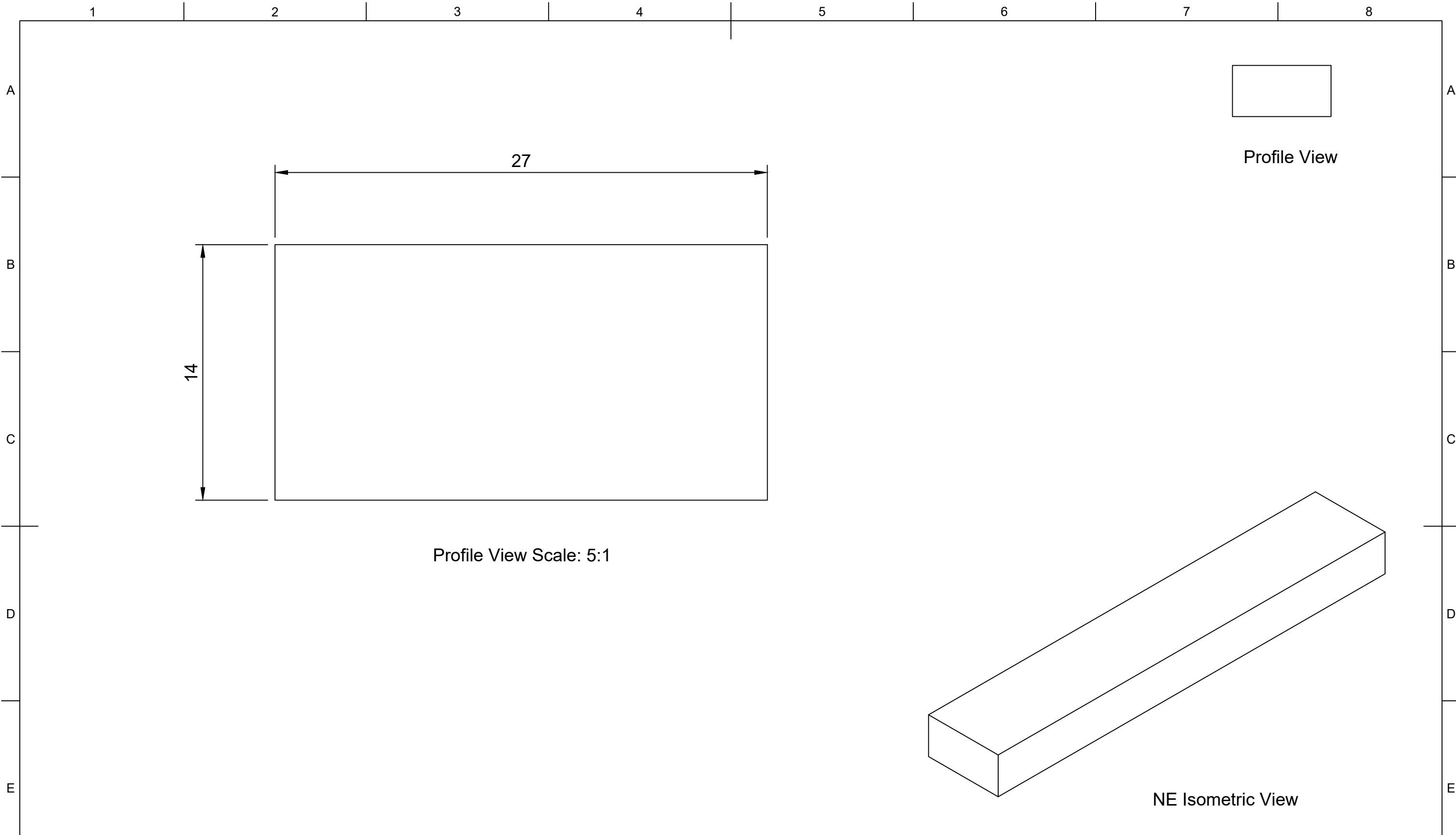

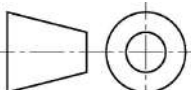
	Part Number				Created By		Cross Sectional Area (mm²)		Nominal Dimension (mm)		Tolerance, ± (mm)
	205850				Isaac Erskine		378		Greater Than	Less Than or Equal to	
	Description				Date Drawn		Material		0.00	1.50	0.40
	Rectangle - Solid				01/08/2020		Nitrile		1.50	2.50	0.50
	Revision				Approved By		Hardness (Shore A)		2.50	4.00	0.70
	A	15/02/2022		Isaac Erskine		70		4.00	6.30	0.80	
	Date of Issue		Sheet Scale		Date of Approval		Colour		6.30	10.00	1.00
	15/02/2022		1:1		15/02/2022		Black		10.00	16.00	1.30
	Sheet Size		Sheet		Projection		Weight (g/m)		16.00	25.00	1.60
	A3		1/1		3rd Ang. 		457		25.00	40.00	2.00
								40.00	63.00	2.50	
								63.00	100.00	3.20	
								100.00		3.20%	

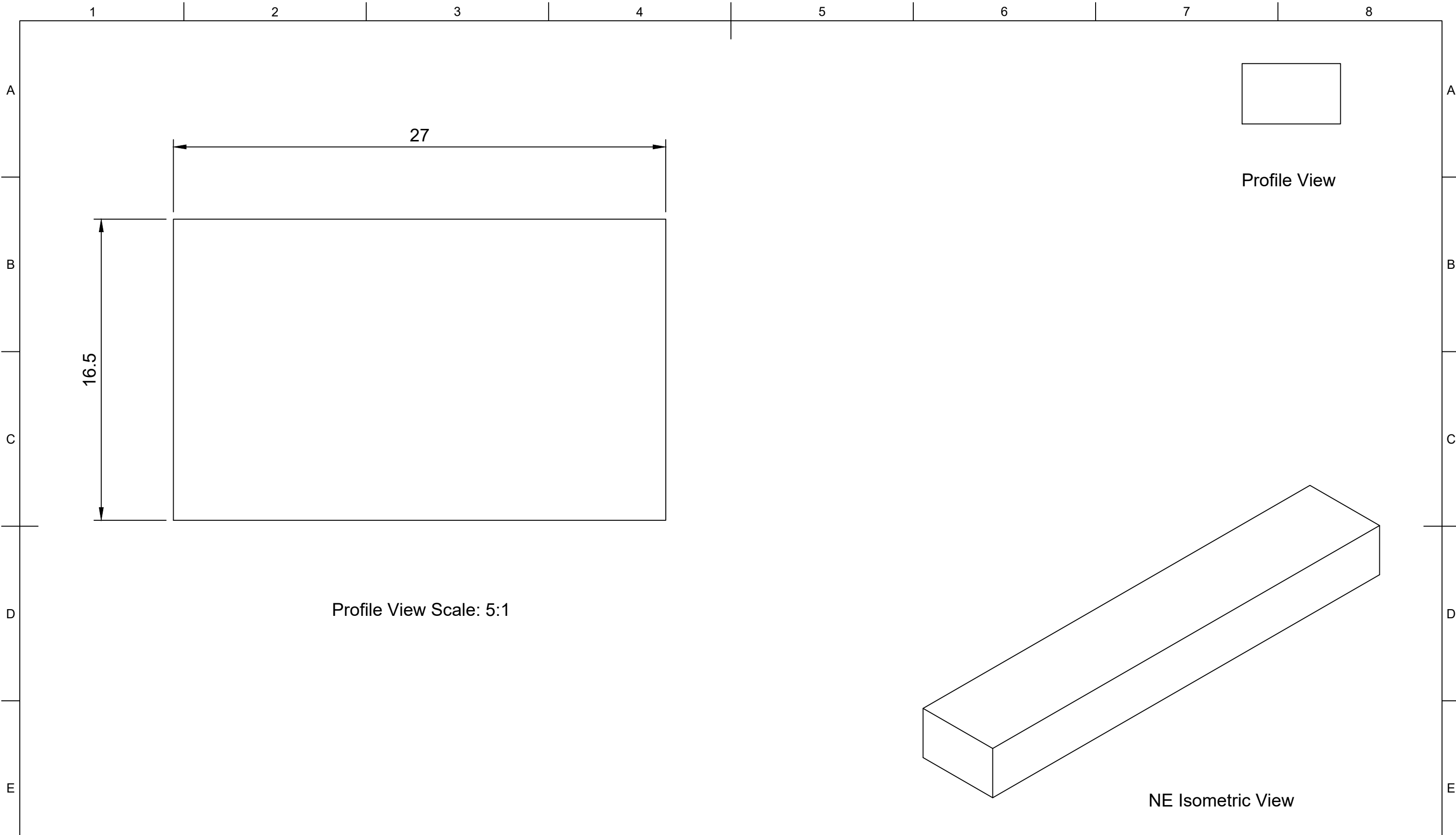

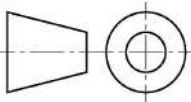
	Part Number				Created By		Cross Sectional Area (mm²)		Nominal Dimension (mm)		Tolerance, ± (mm)	
	202298				Isaac Erskine		446		Greater Than	Less Than or Equal to		
	Description				Date Drawn		Material					
	Rectangle - Solid				01/08/2020		Nitrile				0.40	
	Revision				Approved By		Hardness (Shore A)				1.50	
	A	Date of Issue		Sheet Scale		Isaac Erskine		70				2.50
		15/02/2022		1:1		15/02/2022		Black				4.00
				Sheet Size		Date of Approval		Colour				6.30
				A3		15/02/2022		Black				10.00
				Sheet		Projection		Weight (g/m)				16.00
			1/1		3rd Agl. 		540				25.00	
											40.00	
											63.00	
											100.00	
											3.20%	

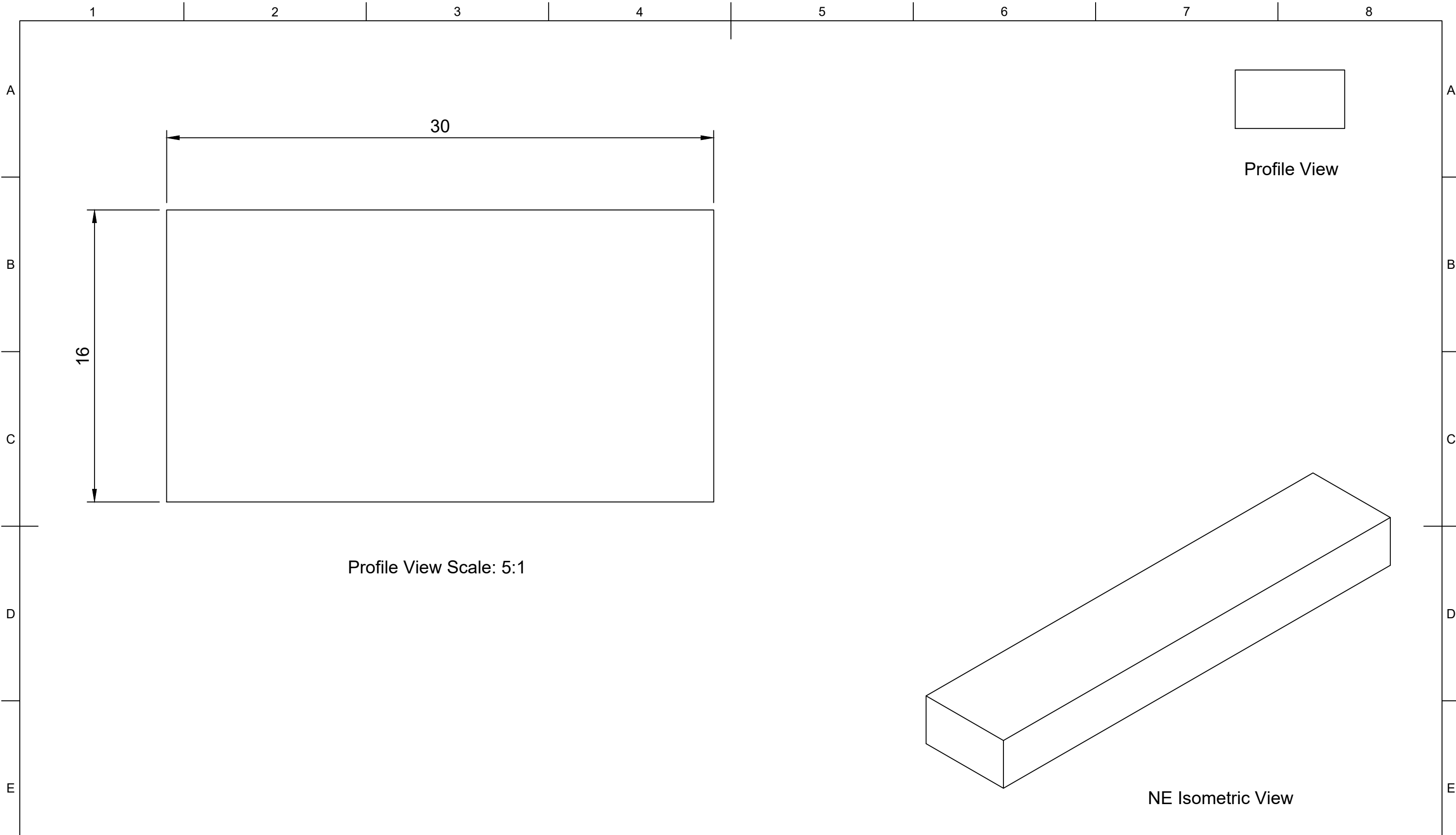

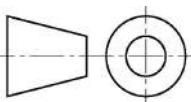
	Part Number					Created By		Cross-Sectional Area (mm²)		Nominal Dimension (mm)		Tolerance, ± (mm)		
	R3016					Kev Parkin		480		Greater Than	Less Than or Equal to	0.40		
						Date Drawn		Material	Hardness (Shore A)	Colour	Weight (kg/m)		0.00	1.50
	Rectangle Section - Solid					Adam Harvey		Neoprene	65	Black	0.730	1.50	2.50	0.50
						Date of Approval		EPDM	70	Black	0.605	2.50	4.00	0.70
						05/08/2020						4.00	6.30	0.80
												6.30	10.00	1.00
	Revision	Date of Issue	Sheet Scale	Sheet Size	Sheet	Projection					10.00	16.00	1.30	
	A	05/08/2020	1:1	A3	1/1	3rd Agl. 					16.00	25.00	1.60	
											25.00	40.00	2.00	
										40.00	63.00	2.50		
										63.00	100.00	3.20		
										100.00		3.20%		

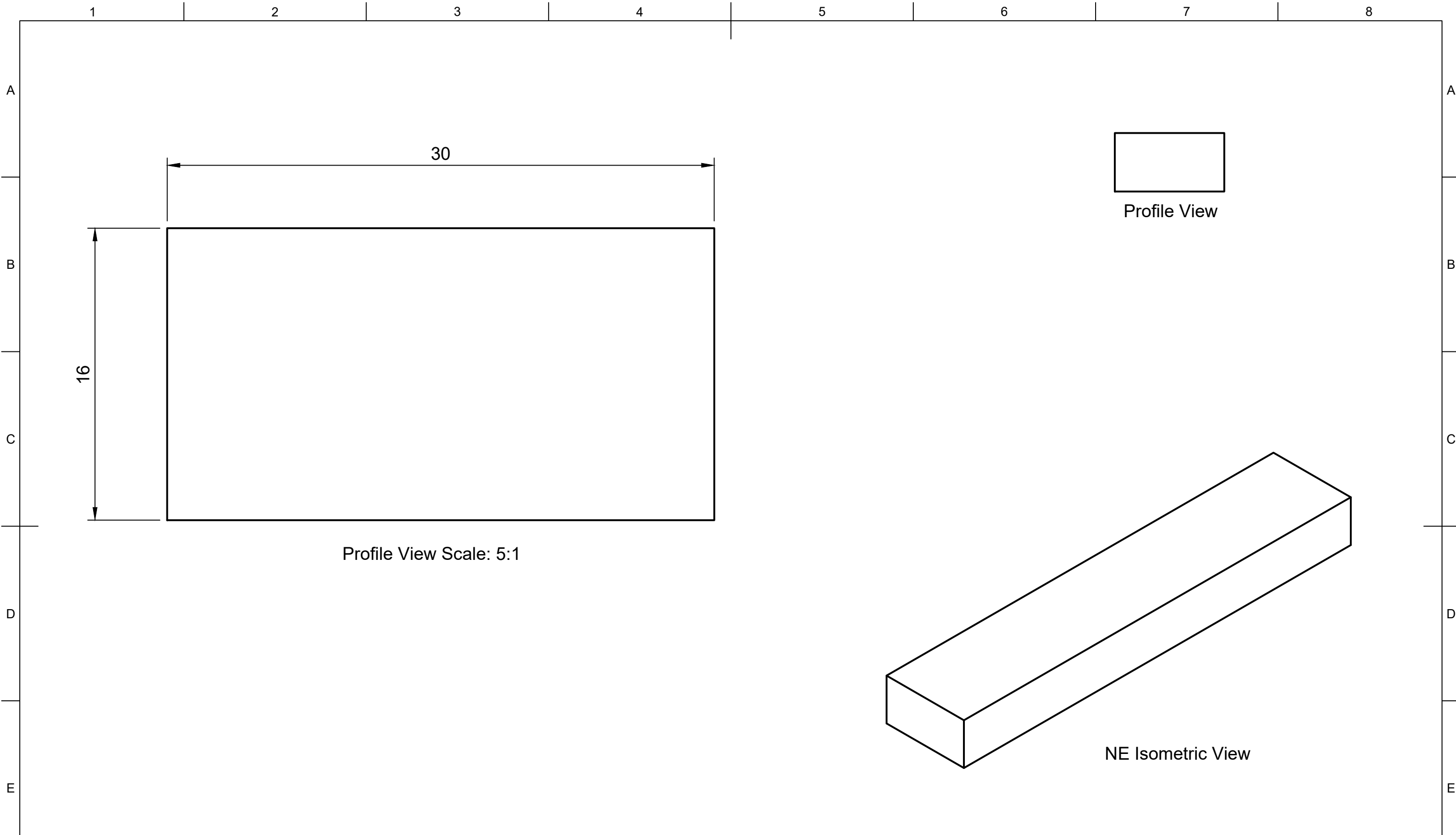

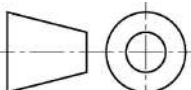
	Part Number				Created By		Cross Sectional Area (mm²)		Nominal Dimension (mm)		Tolerance, ± (mm)
	202390				Isaac Erskine		480		Greater Than	Less Than or Equal to	
	Description				Date Drawn		Material		0.00	1.50	0.40
	Rectangle - Solid				15/02/2022		Neoprene		1.50	2.50	0.50
	Revision				Approved By		Hardness (Shore A)		2.50	4.00	0.70
	A	15/02/2022		Isaac Erskine		70		4.00	6.30	0.80	
	Date of Issue		Sheet Scale		Date of Approval		Colour		6.30	10.00	1.00
	15/02/2022		1:1		15/02/2022		Black		10.00	16.00	1.30
	Sheet Size		Sheet		Projection		Weight (g/m)		16.00	25.00	1.60
	A3		1/1		3rd Agl. 		730		25.00	40.00	2.00
								40.00	63.00	2.50	
								63.00	100.00	3.20	
								100.00		3.20%	

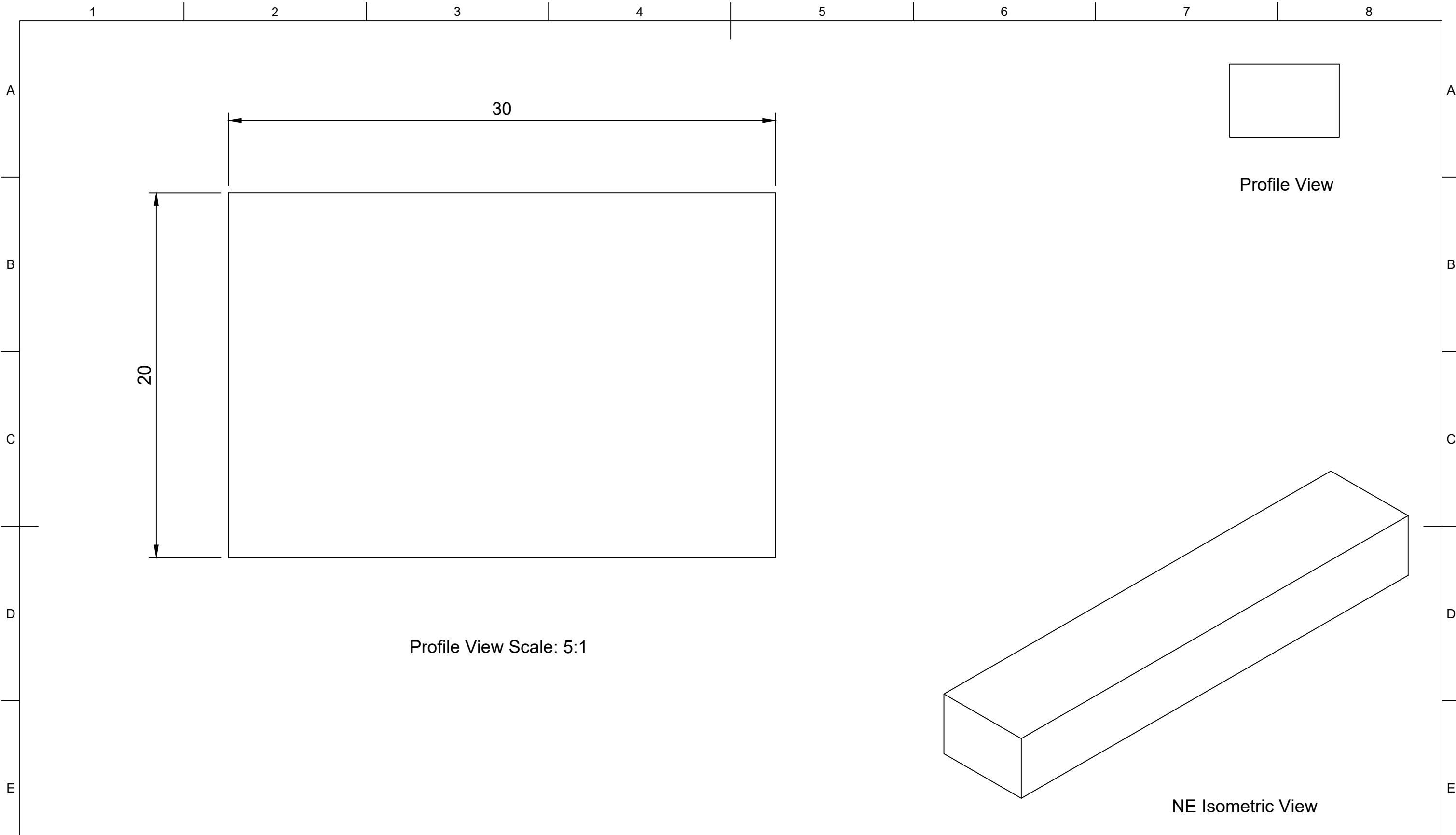

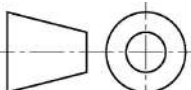
	Part Number				Created By		Cross Sectional Area (mm²)		Nominal Dimension (mm)		Tolerance, ± (mm)	
	209368				Isaac Erskine		600		Greater Than	Less Than or Equal to		
	Description				Date Drawn		Material		0.00		0.40	
	Rectangle - Solid				01/08/2020		EPDM		1.50		0.50	
	Revision				Approved By		Hardness (Shore A)		2.50		0.70	
	A	Date of Issue		Sheet Scale		Isaac Erskine		70		4.00		0.80
		15/02/2022		1:1		15/02/2022		Colour		6.30		1.00
				Sheet Size		Date of Approval		Black		10.00		1.30
				A3		15/02/2022		Weight (g/m)		16.00		1.60
				1/1		Projection		756		25.00		2.00
					3rd Agl. 				40.00		2.50	
									63.00		3.20	
									100.00		3.20%	

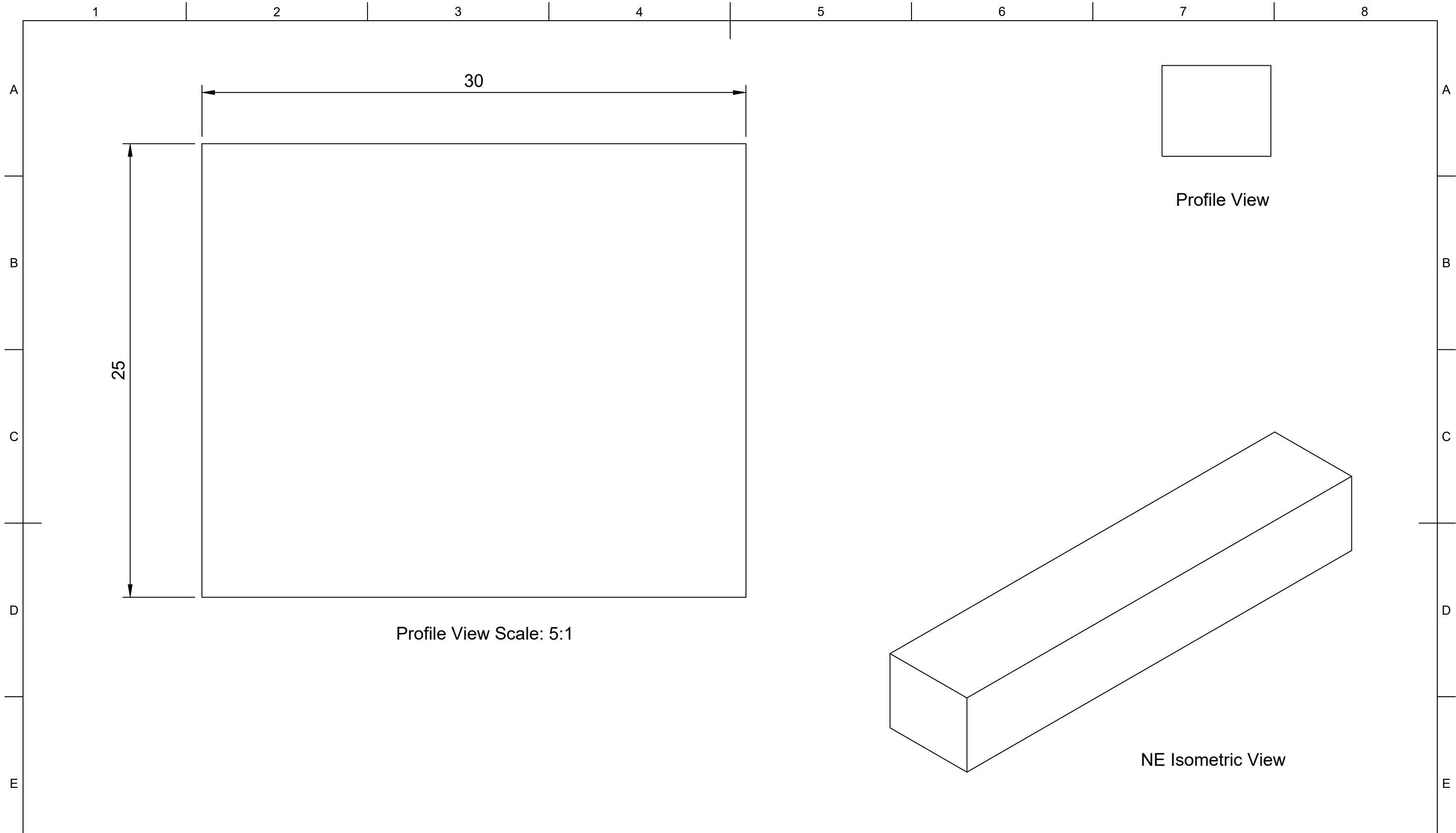

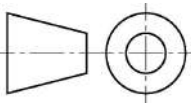
	Part Number				Created By		Cross Sectional Area (mm²)		Nominal Dimension (mm)		Tolerance, ± (mm)
	206906				Isaac Erskine		749		Greater Than	Less Than or Equal to	
	Description				Date Drawn		Material				
	Rectangle - Solid				01/08/2020		EPDM				
					Approved By		Hardness (Shore A)				
					Isaac Erskine		70				
					Date of Approval		Colour				
					15/02/2022		Black				
					Projection		Weight (g/m)				
					3rd Agl. 		944				
Revision	Date of Issue	Sheet Scale	Sheet Size	Sheet							
A	15/02/2022	1:1	A3	1/1							

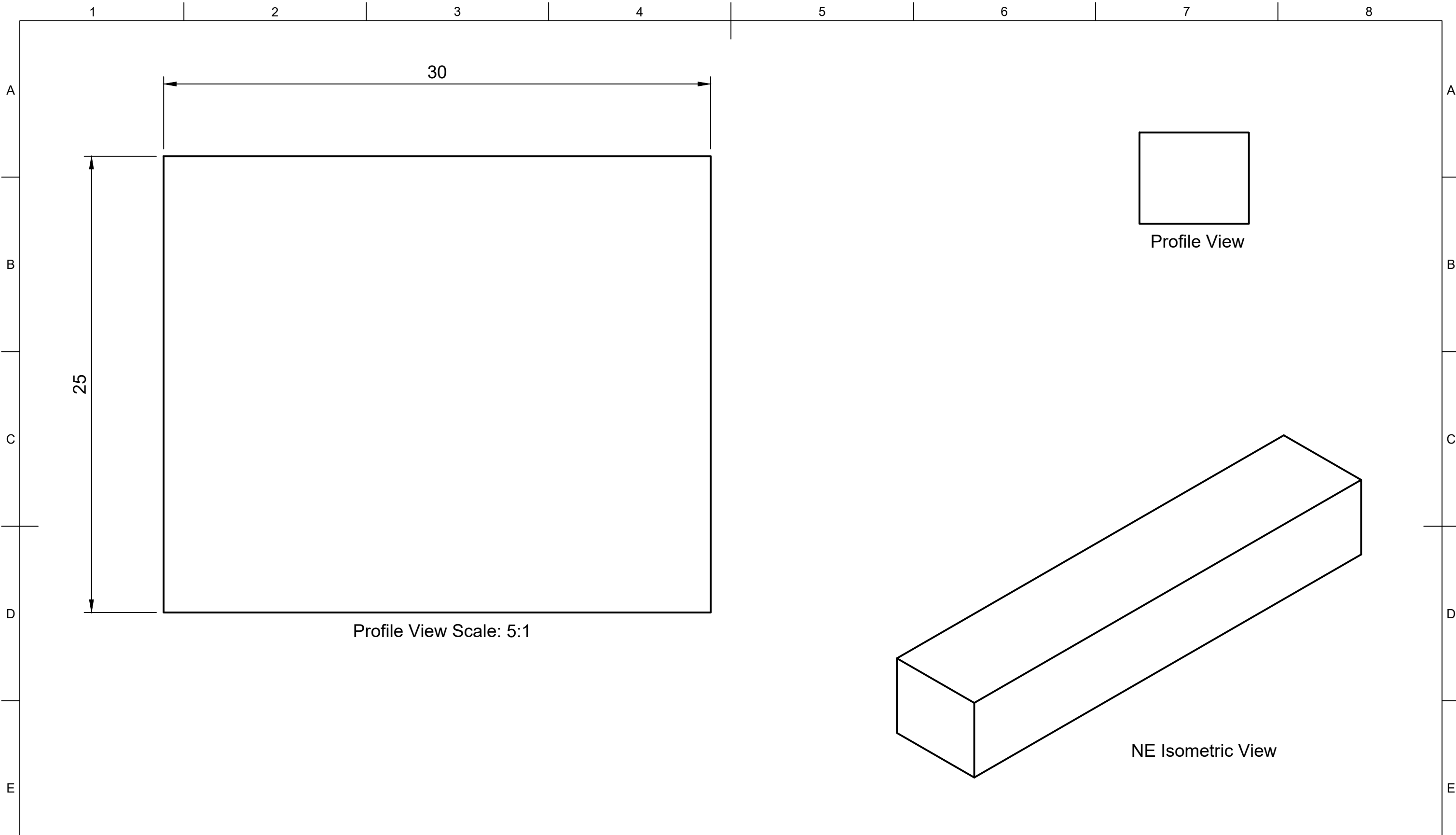

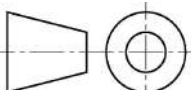
	Part Number				Created By		Cross Sectional Area (mm²)		Nominal Dimension (mm)		Tolerance, ± (mm)
	202742				Isaac Erskine		749		Greater Than	Less Than or Equal to	
	Description				Date Drawn		Material		0.00		0.40
	Rectangle - Solid				15/02/2022		Neoprene		1.50		0.50
	Revision				Approved By		Hardness (Shore A)		2.50		0.70
	A	15/02/2022		Isaac Erskine		70		4.00		0.80	
	Date of Issue				Date of Approval		Colour		6.30		1.00
	15/02/2022				15/02/2022		Black		10.00		1.30
	Sheet Scale				Projection		Weight (kg/m)		16.00		1.60
	1:1				3rd Agl. 		1.138		25.00		2.00
Sheet Size								40.00		2.50	
A3								63.00		3.20	
Sheet								100.00		3.20%	
1/1											

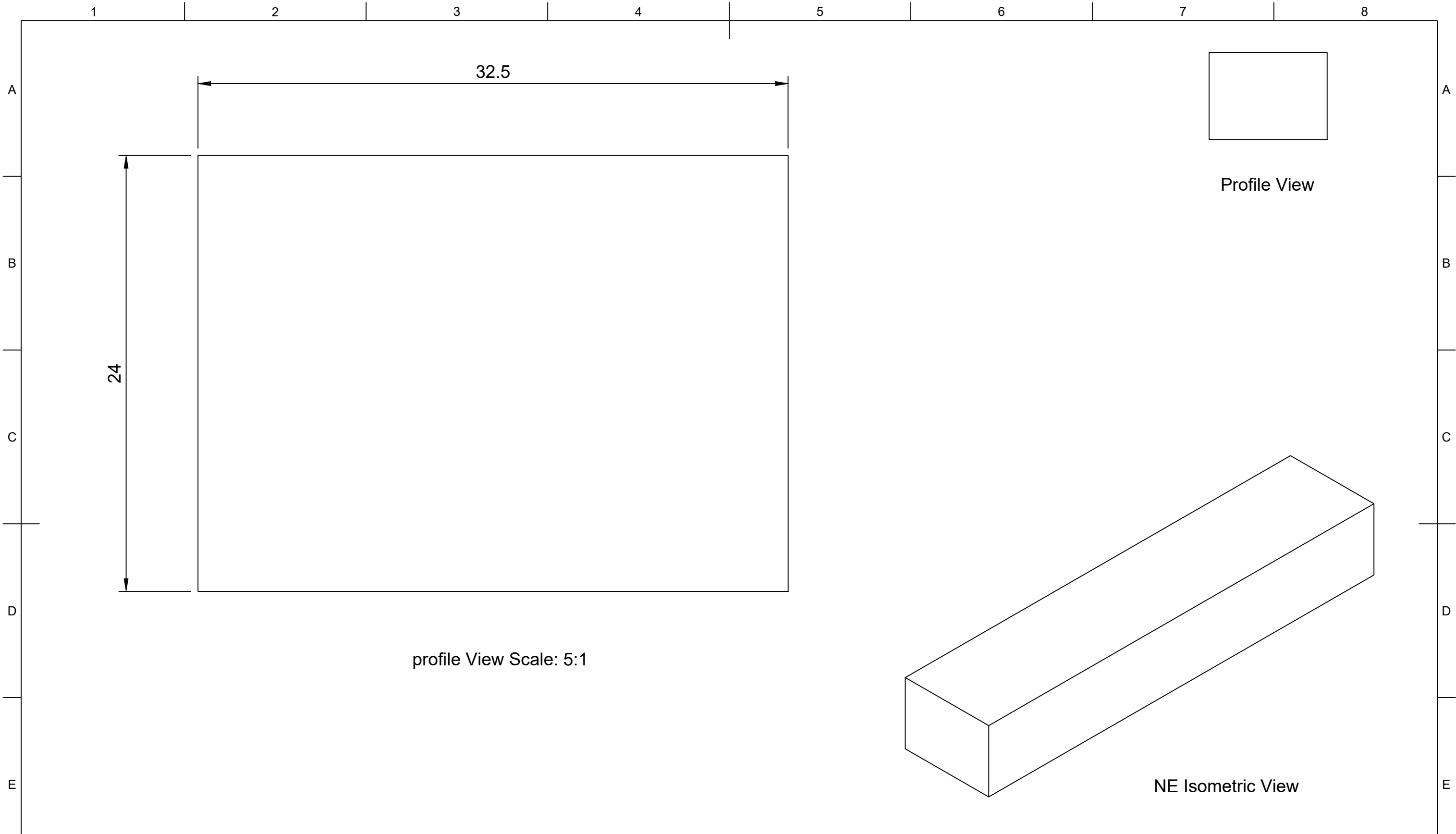

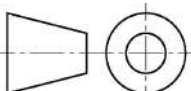
	Part Number				Created By		Cross Sectional Area (mm²)		Nominal Dimension (mm)		Tolerance, ± (mm)
	201224				Isaac Erskine		780		Greater Than	Less Than or Equal to	
	Description				Date Drawn		Material				
	Rectangle - Solid				01/08/2020		EPDM				
	Revision				Approved By		Hardness (Shore A)				
	A	15/02/2022		Isaac Erskine		70					
	Date of Issue		Sheet Scale		Date of Approval		Colour				
	15/02/2022		1:1		15/02/2022		Black				
	Sheet Size		Sheet		Projection		Weight (g/m)				
	A3		1/1		3rd Agl. 		983				
								25.00	40.00	2.00	
								40.00	63.00	2.50	
								63.00	100.00	3.20	
								100.00		3.20%	

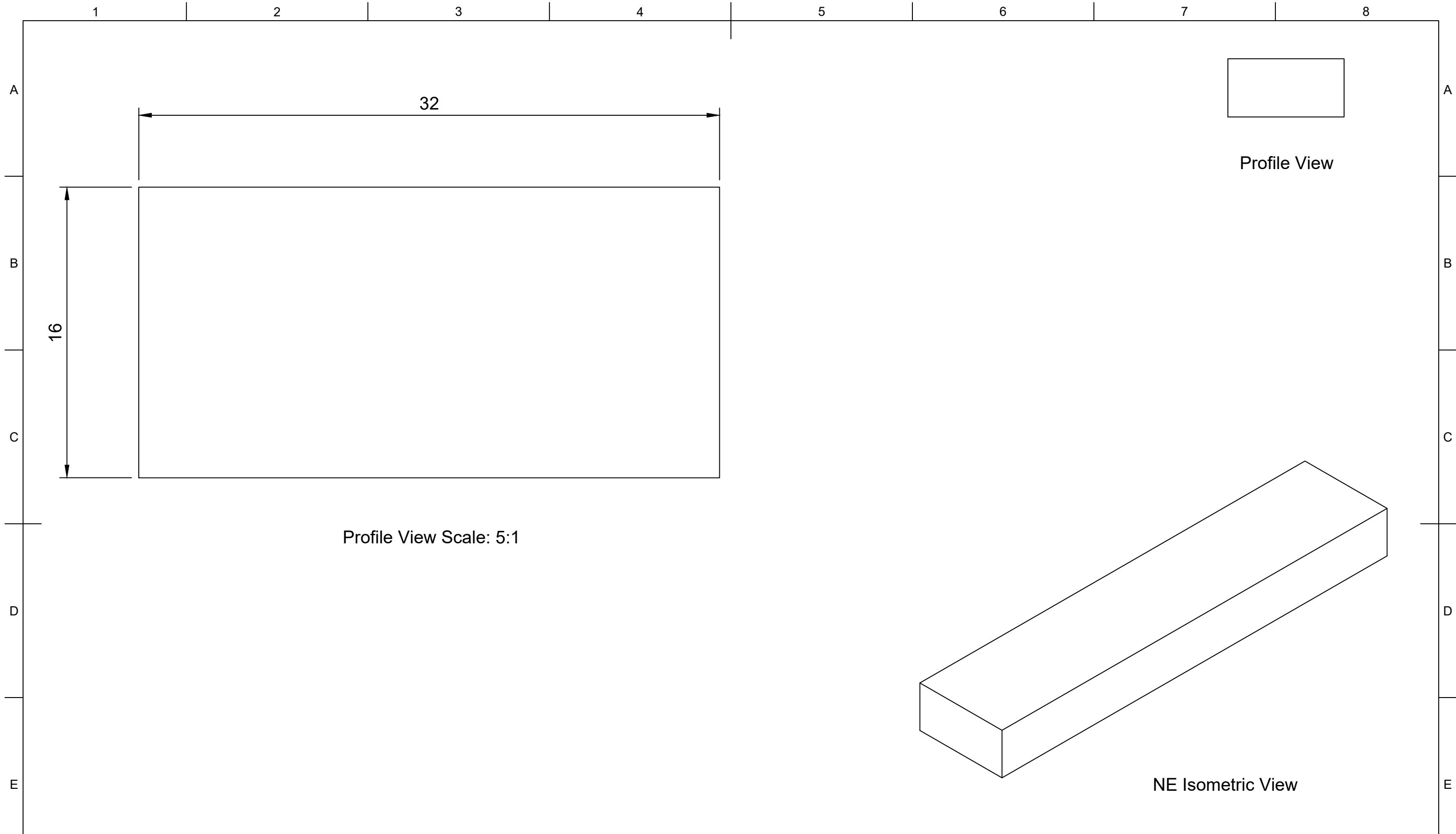

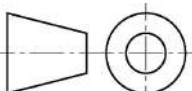
	Part Number				Created By		Cross Sectional Area (mm²)		Nominal Dimension (mm)		Tolerance, ± (mm)	
	202200				Isaac Erskine		512		Greater Than	Less Than or Equal to		
	Description				Date Drawn		Material		0.00		0.40	
	Rectangle - Solid				01/08/2020		Nitrile		1.50		0.50	
	Revision				Approved By		Hardness (Shore A)		2.50		0.70	
	A	Date of Issue		Sheet Scale		Isaac Erskine		70		4.00		0.80
		15/02/2022		1:1		15/02/2022		Black		6.30		1.00
				Sheet Size		Date of Approval		Colour		10.00		1.30
				A3		15/02/2022		Black		16.00		1.60
				Sheet		Projection		Weight (g/m)		25.00		2.00
			1/1		3rd Ang. 		620		40.00		2.50	
									63.00		3.20	
									100.00		3.20%	

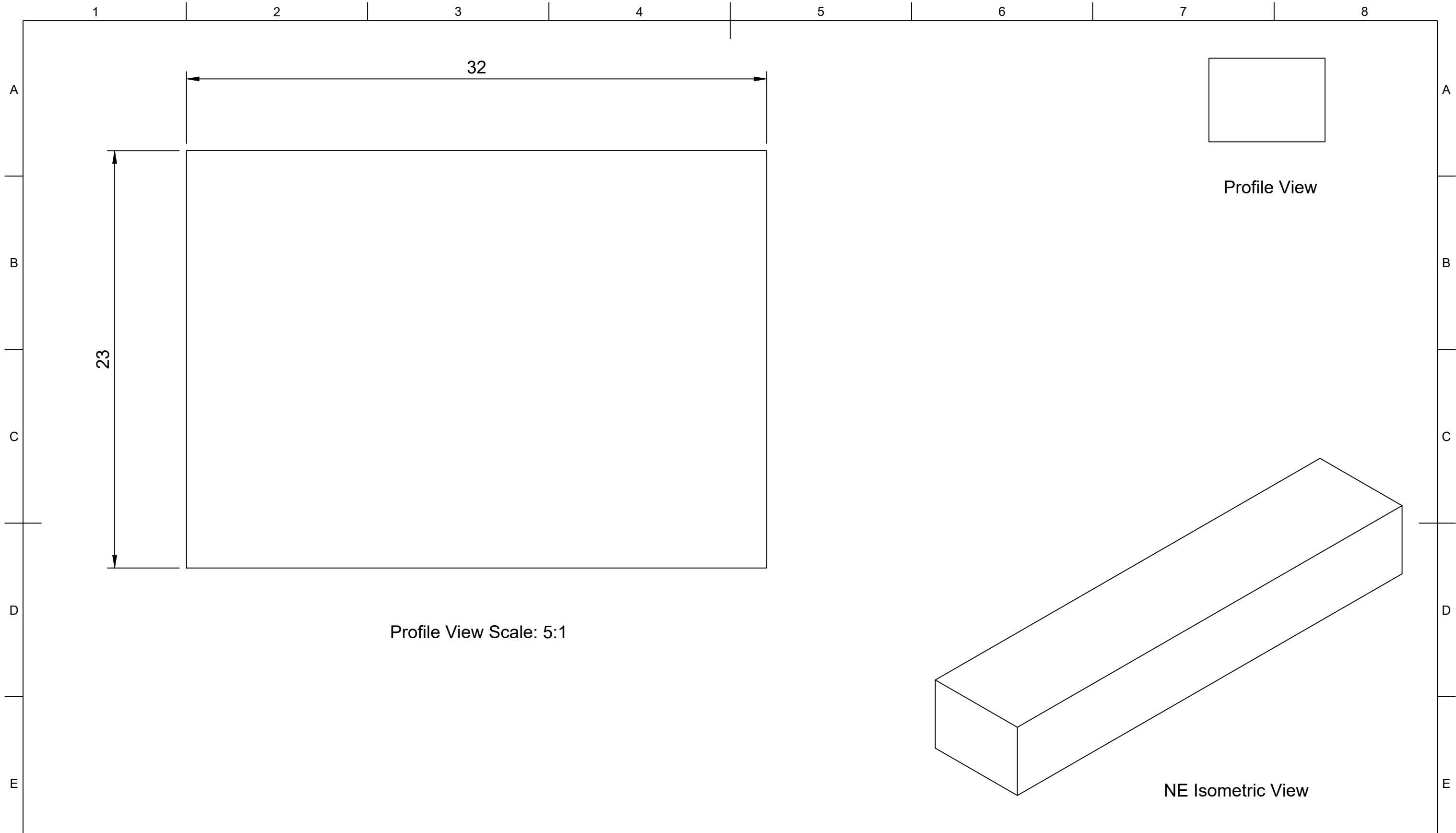

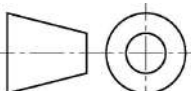
	Part Number				Created By		Cross Sectional Area (mm²)		Nominal Dimension (mm)		Tolerance, ± (mm)
	204307				Isaac Erskine		736		Greater Than	Less Than or Equal to	
	Description				Date Drawn		Material		0.00		0.40
	Rectangle - Solid				01/08/2020		EPDM		1.50		0.50
	Revision				Approved By		Hardness (Shore A)		2.50		0.70
	A	15/02/2022		Isaac Erskine		70		4.00		0.80	
	Date of Issue		Sheet Scale		Date of Approval		Colour		6.30		1.00
	15/02/2022		1:1		15/02/2022		Black		10.00		1.30
	Sheet Size		Sheet		Projection		Weight (g/m)		16.00		1.60
	A3		1/1		3rd Ang. 		927		25.00		2.00
								40.00		2.50	
								63.00		3.20	
								100.00		3.20%	

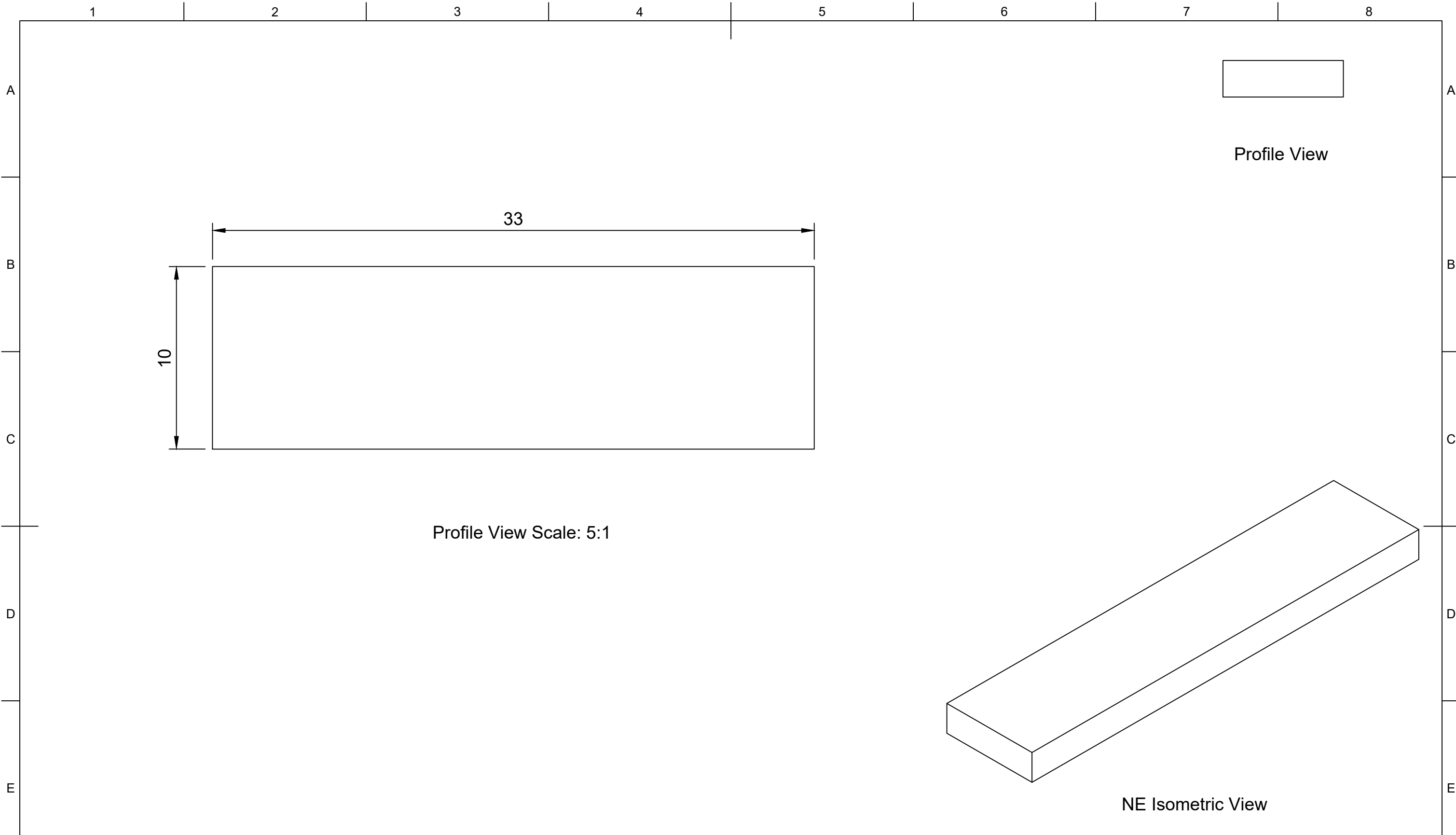

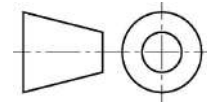
	Part Number				Created By		Cross Sectional Area (mm²)		Nominal Dimension (mm)		Tolerance, ± (mm)
	202138				Isaac Erskine		330		Greater Than	Less Than or Equal to	
					Date Drawn		Material		0.00	1.50	0.40
					10/08/2020		EPDM		1.50	2.50	0.50
	Description				Approved By		Hardness (Shore A)		2.50	4.00	0.70
	Rectangle - Solid				Isaac Erskine		70		4.00	6.30	0.80
					Date of Approval		Colour		6.30	10.00	1.00
					15/02/2022		Black		10.00	16.00	1.30
							Weight (g/m)		16.00	25.00	1.60
							416		25.00	40.00	2.00
Revision	Date of Issue	Sheet Scale	Sheet Size	Sheet	Projection			40.00	63.00	2.50	
A	15/02/2022	1:1	A3	1/1	3rd Agl.			63.00	100.00	3.20	
								100.00		3.20%	

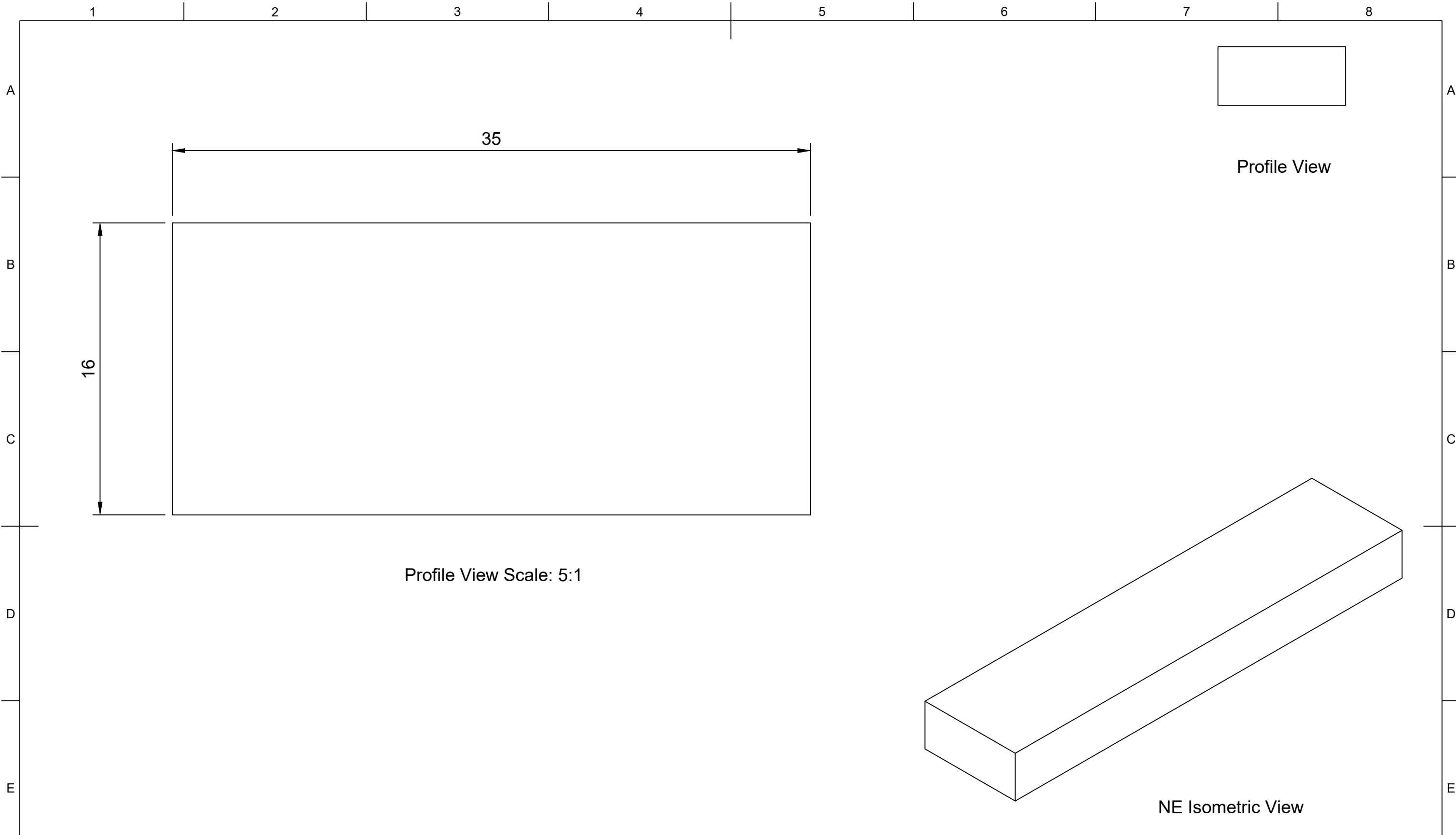

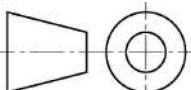

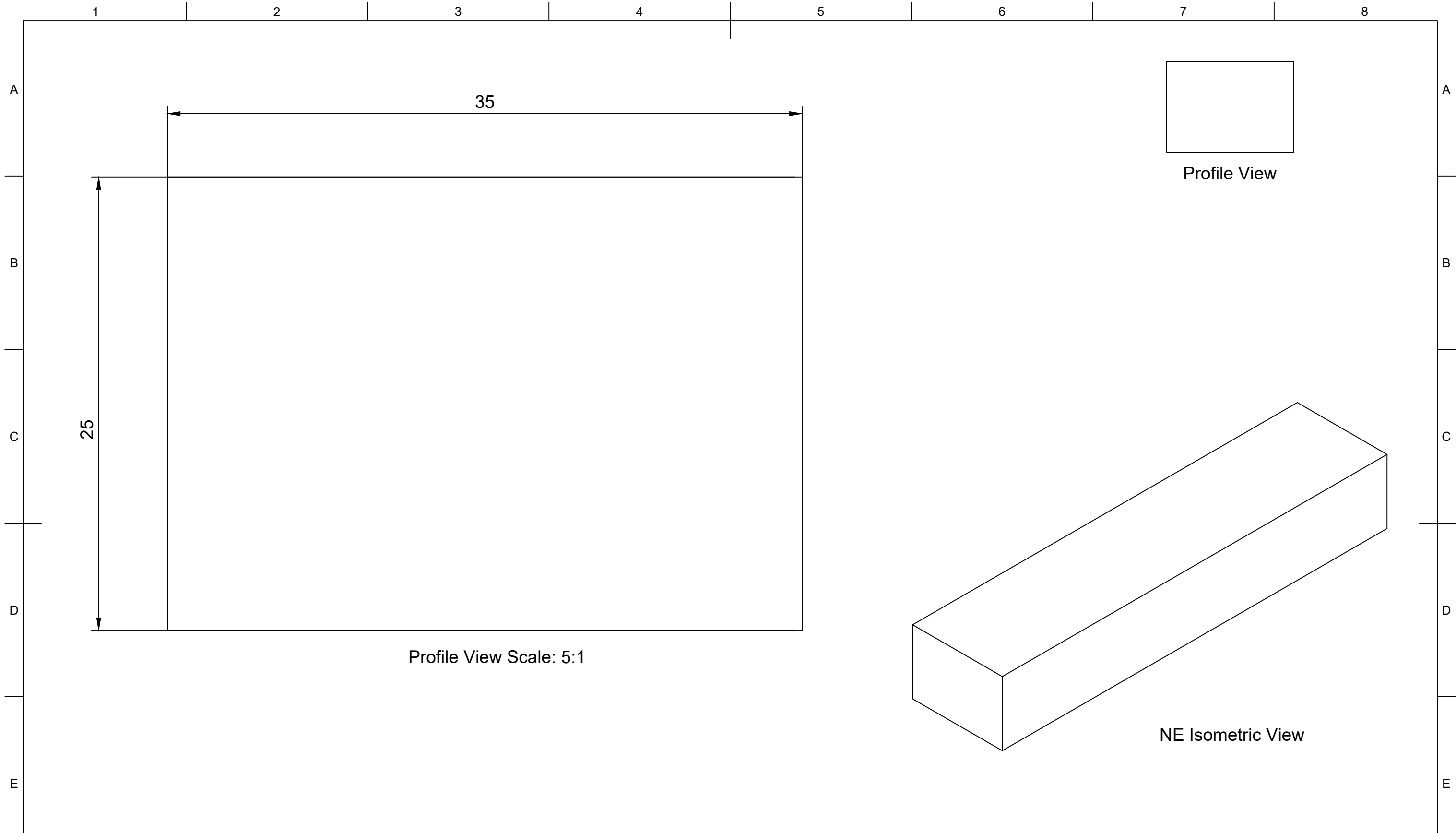
	Part Number				Created By		Cross Sectional Area (mm²)		Nominal Dimension (mm)		Tolerance, ± (mm)
	209380				Isaac Erskine		560		Greater Than	Less Than or Equal to	
	Description				Date Drawn		Material		0.00	1.50	0.40
	Rectangle - Solid				10/08/2020		Neoprene		1.50	2.50	0.50
	Revision				Approved By		Hardness (Shore A)		2.50	4.00	0.70
	A	15/02/2022		Isaac Erskine		70		4.00	6.30	0.80	
	Date of Issue		Sheet Scale		Date of Approval		Colour		6.30	10.00	1.00
	15/02/2022		1:1		15/02/2022		Black		10.00	16.00	1.30
	Sheet Size		Sheet		Projection		Weight (g/m)		16.00	25.00	1.60
	A3		1/1		3rd Agl. 		851		25.00	40.00	2.00
								40.00	63.00	2.50	
								63.00	100.00	3.20	
								100.00		3.20%	

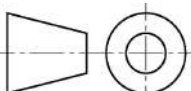

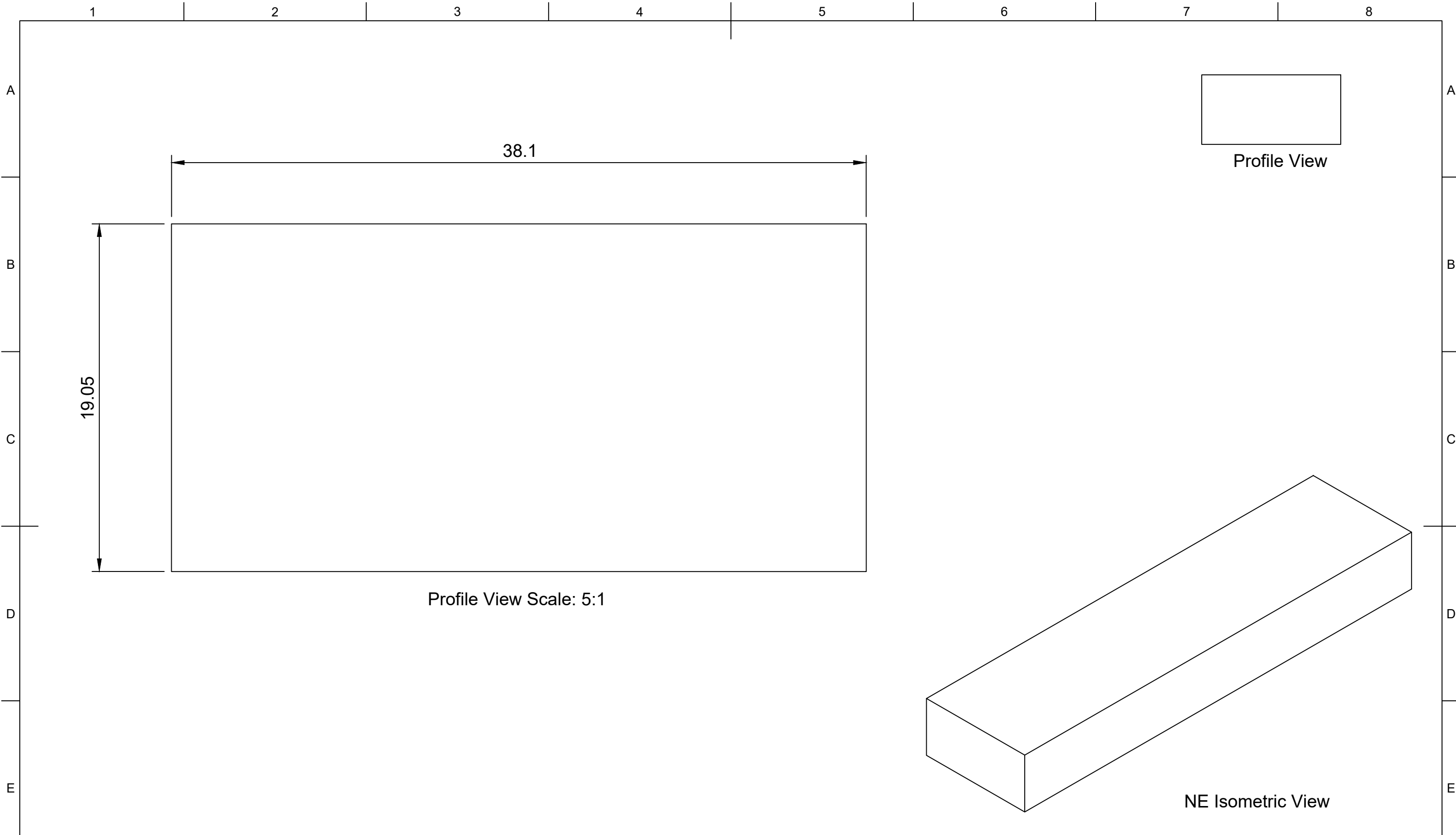

	Part Number				Created By		Cross Sectional Area (mm²)		Nominal Dimension (mm)		Tolerance, ± (mm)
	202254				Isaac Erskine		875		Greater Than	Less Than or Equal to	
					Date Drawn		Material		0.00	1.50	0.40
					29/06/2020		EPDM		1.50	2.50	0.50
	Description				Approved By		Hardness (Shore A)		2.50	4.00	0.70
	Rectangle - Solid				Isaac Erskine		70		4.00	6.30	0.80
					Date of Approval		Colour		6.30	10.00	1.00
					15/02/2022		Black		10.00	16.00	1.30
							Weight (kg/m)		16.00	25.00	1.60
							1.103		25.00	40.00	2.00
Revision	Date of Issue	Sheet Scale	Sheet Size	Sheet	Projection			40.00	63.00	2.50	
A	15/02/2022	1:1	A3	1/1	3rd Agl. 			63.00	100.00	3.20	
								100.00		3.20%	

1 2 3 4 5 6 7 8

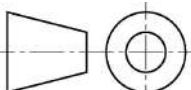

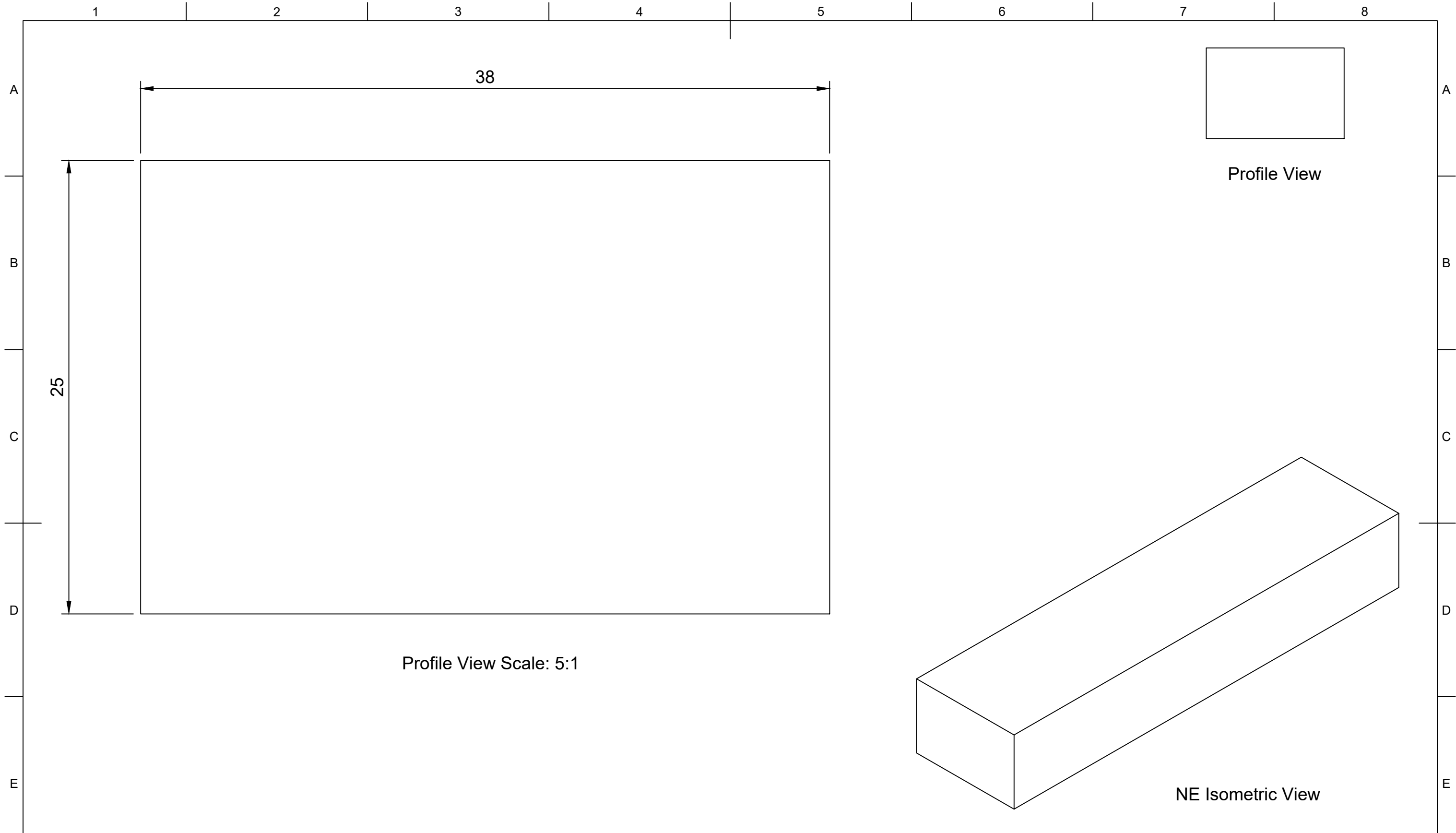
	Part Number				Created By		Cross Sectional Area (mm²)		Nominal Dimension (mm)		Tolerance, ± (mm)
	206199				Isaac Erskine		726		Greater Than	Less Than or Equal to	
	Description				Date Drawn		Material		0.00	1.50	0.40
	Rectangle - Solid				10/08/2020		EPDM		1.50	2.50	0.50
	Revision				Approved By		Hardness (Shore A)		2.50	4.00	0.70
	A	15/02/2022		Isaac Erskine		70		4.00	6.30	0.80	
	Date of Issue		Sheet Scale		Date of Approval		Colour		6.30	10.00	1.00
	15/02/2022		1:1		15/02/2022		Black		10.00	16.00	1.30
	Sheet Size		Sheet		Projection		Weight (g/m)		16.00	25.00	1.60
	A3		1/1		3rd Agl. 		915		25.00	40.00	2.00
								40.00	63.00	2.50	
								63.00	100.00	3.20	
								100.00		3.20%	

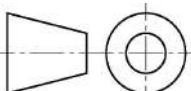

	Part Number				Created By		Cross Sectional Area (mm²)		Nominal Dimension (mm)		Tolerance, ± (mm)
	208212				Adam Harvey		950		Greater Than	Less Than or Equal to	
	Description				Date Drawn		Material		0.00	1.50	0.40
	Rectangle - Solid				10/08/2020		EPDM		1.50	2.50	0.50
	Revision				Approved By		Hardness (Shore A)		2.50	4.00	0.70
	A	15/02/2022		1:1	A3	Ivan Browne	70		4.00	6.30	0.80
	Date of Issue		Sheet Scale		Sheet Size		Colour		6.30	10.00	1.00
	15/02/2022		1:1		A3		Black		10.00	16.00	1.30
	Sheet		Projection		Weight (kg/m)				16.00	25.00	1.60
	1/1		3rd Agl. 		1.197				25.00	40.00	2.00
								40.00	63.00	2.50	
								63.00	100.00	3.20	
								100.00		3.20%	

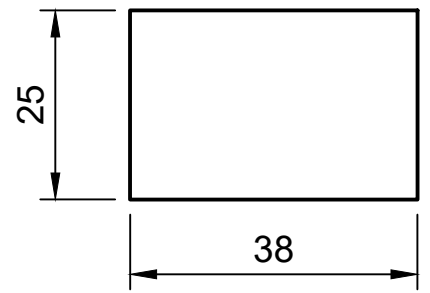
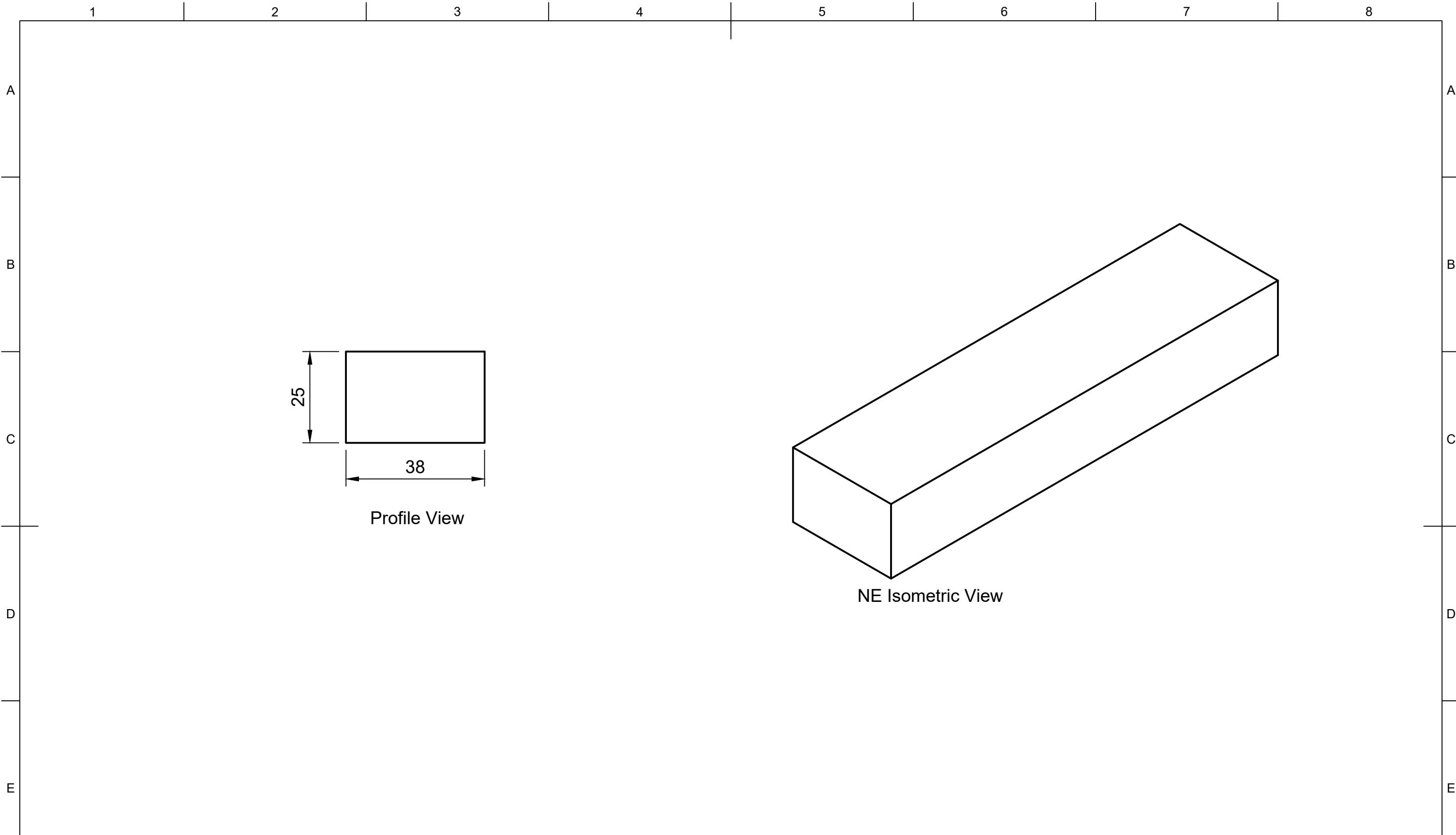

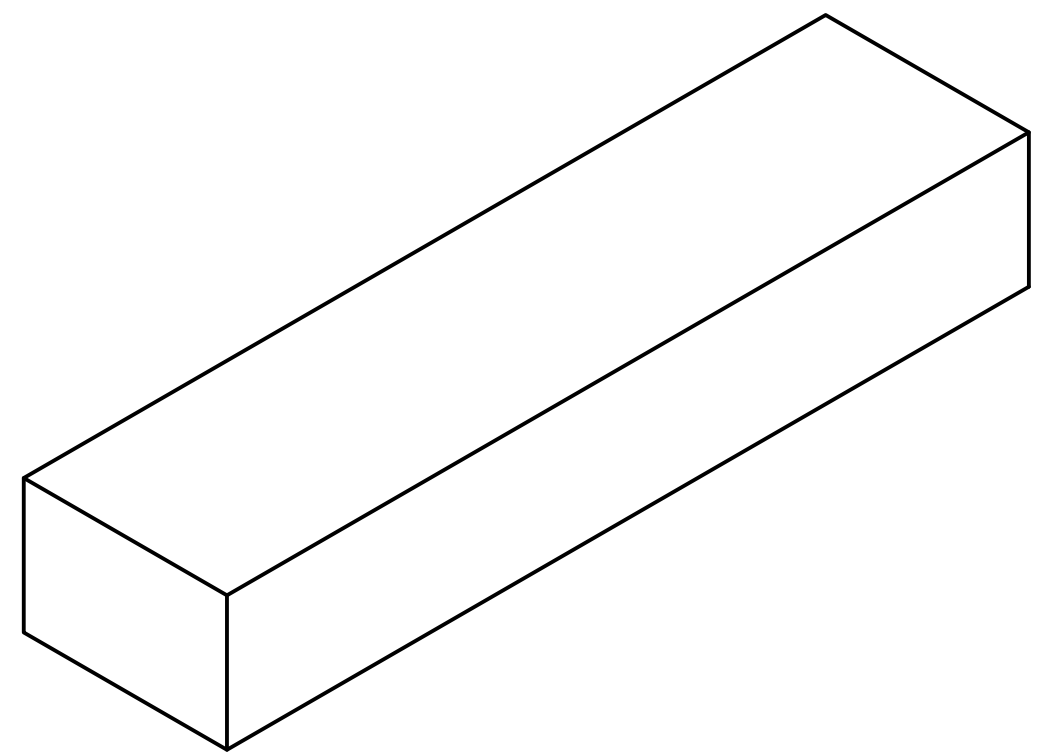

Profile View



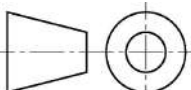

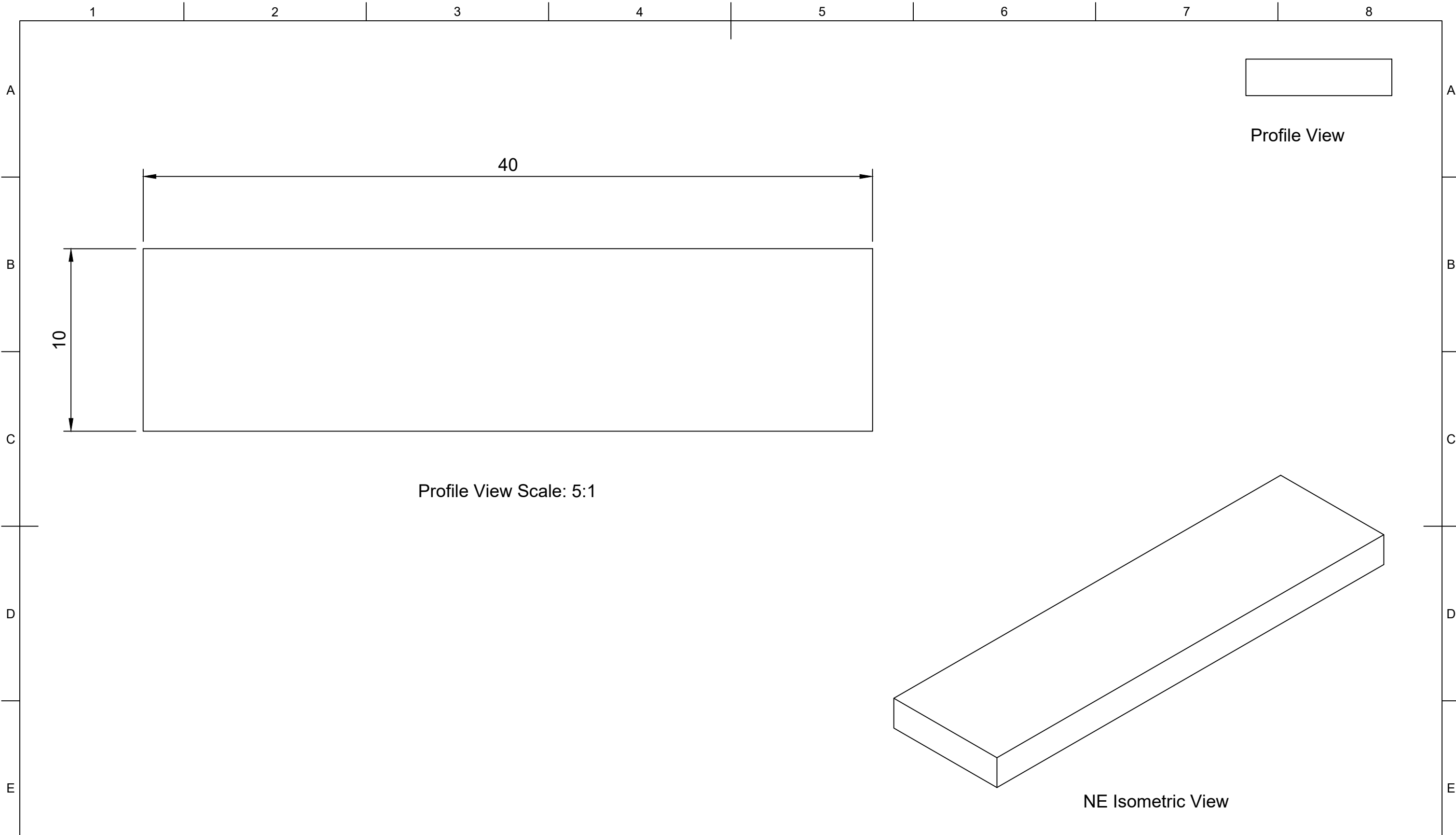
NE Isometric View

	Part Number				Created By		Cross Sectional Area (mm²)		Nominal Dimension (mm)		Tolerance, ± (mm)
	208252				Adam Harvey		950		Greater Than	Less Than or Equal to	
	Description				Date Drawn		Material		0.00	1.50	0.40
					15/02/2022		Neoprene		1.50	2.50	0.50
	Rectangle - Solid				Approved By		Hardness (Shore A)		2.50	4.00	0.70
					Ivan Browne		70		4.00	6.30	0.80
					Date of Approval		Colour		6.30	10.00	1.00
	15/02/2022		Black		10.00	16.00	1.30				
	16.00		25.00		16.00	25.00	1.60				
	25.00		40.00		25.00	40.00	2.00				
40.00		63.00		40.00	63.00	2.50					
63.00		100.00		63.00	100.00	3.20					
100.00				100.00		3.20%					
Revision	Date of Issue	Sheet Scale	Sheet Size	Sheet	Projection	Weight (g/m)					
A	15/02/2022	1:1	A3	1/1	3rd Agl. 	1.444					

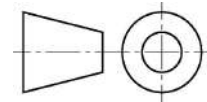

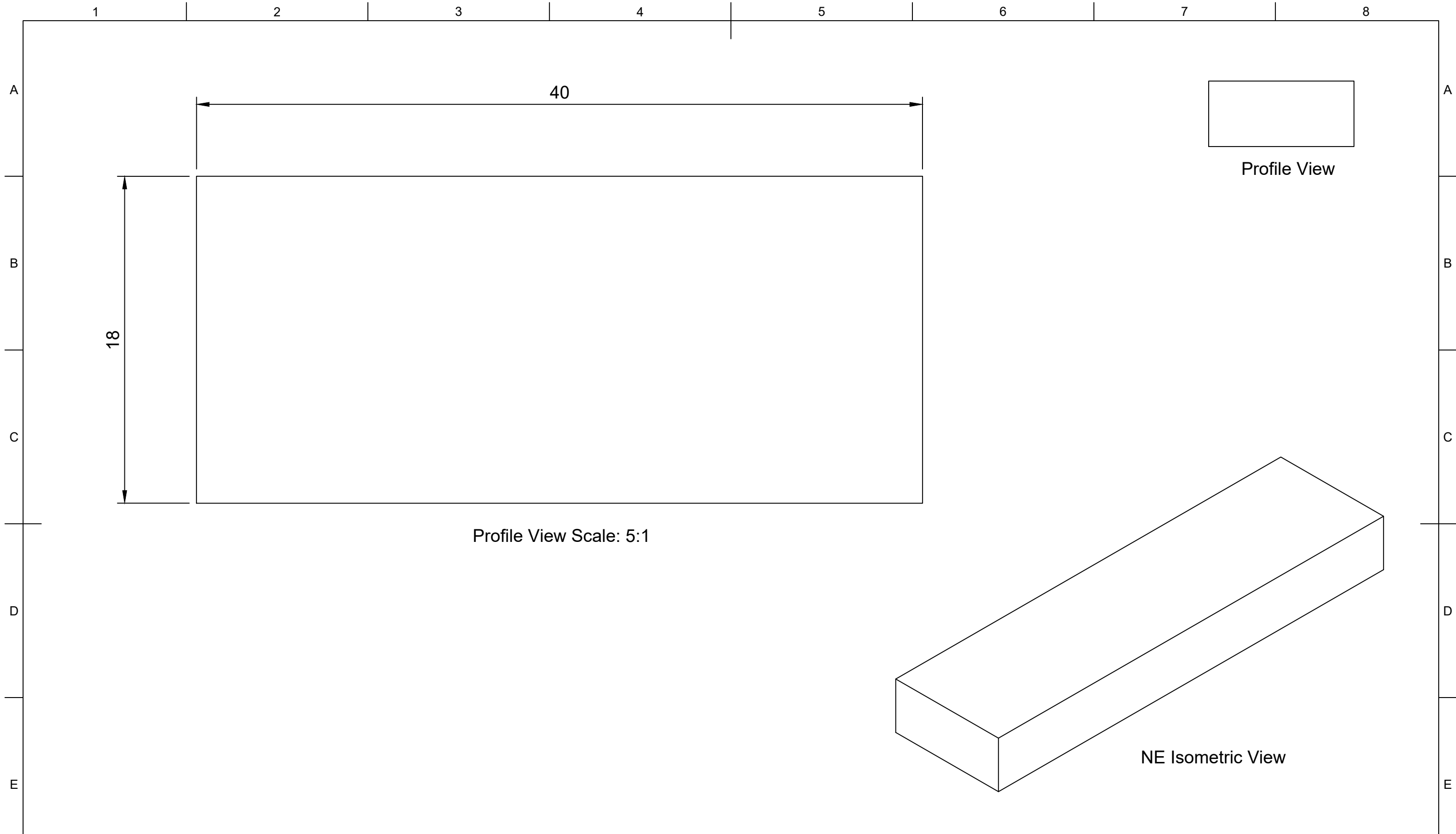
	Part Number				Created By		Cross Sectional Area (mm²)		Nominal Dimension (mm)		Tolerance, ± (mm)		
	205015				Isaac Erskine		400		Greater Than	Less Than or Equal to			
	Description				Date Drawn		Material		0.00	1.50	0.40		
	Rectangle - Solid				10/08/2020		EPDM		1.50	2.50	0.50		
	Revision				Approved By		Hardness (Shore A)		2.50	4.00	0.70		
	A	15/02/2022		1:1	A3	1/1	Isaac Erskine		4.00	6.30	0.80		
	Date of Issue		Sheet Scale		Sheet Size		Date of Approval		Colour		6.30	10.00	1.00
	15/02/2022		1:1		A3		15/02/2022		Black		10.00	16.00	1.30
	Projection				Weight (g/m)		3rd Agl.		16.00	25.00	1.60		
					504				25.00	40.00	2.00		
								40.00	63.00	2.50			
								63.00	100.00	3.20			
								100.00		3.20%			

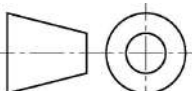

	Part Number				Created By		Cross Sectional Area (mm²)		Nominal Dimension (mm)		Tolerance, ± (mm)
	206083				Isaac Erskine		720		Greater Than	Less Than or Equal to	
	Description				Date Drawn		Material		0.00		0.40
	Rectangle - Solid				10/08/2020		EPDM		1.50		0.50
	Revision				Approved By		Hardness (Shore A)		2.50		0.70
	A	15/02/2022		Isaac Erskine		70		4.00		0.80	
	Date of Issue		Sheet Scale		Date of Approval		Colour		6.30		1.00
	15/02/2022		1:1		15/02/2022		Black		10.00		1.30
	Sheet Size		Sheet		Projection		Weight (g/m)		16.00		1.60
	A3		1/1		3rd Ang. 		907		25.00		2.00
								40.00		2.50	
								63.00		3.20	
								100.00		3.20%	

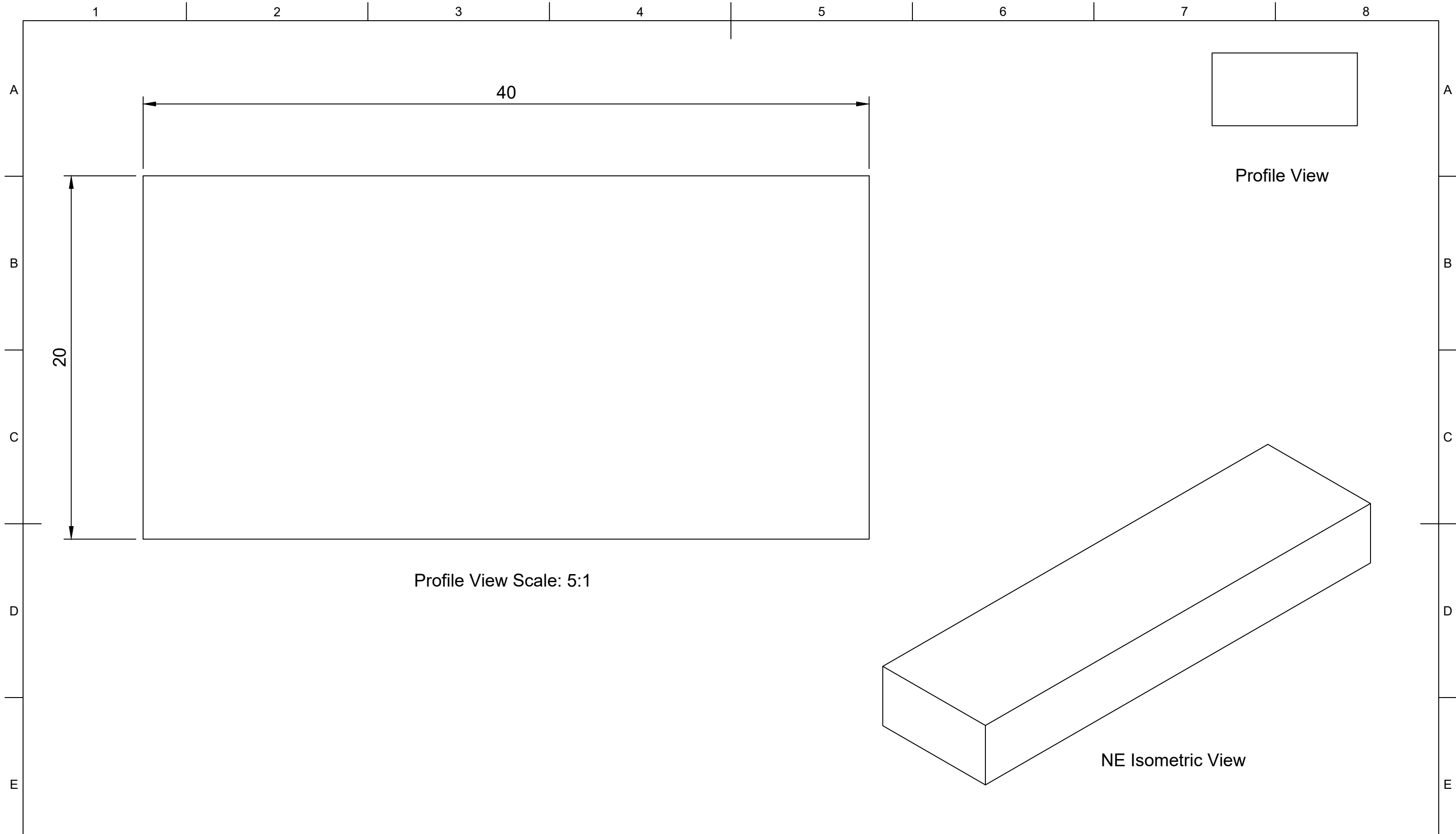

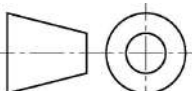
	Part Number				Created By		Cross Sectional Area (mm²)		Nominal Dimension (mm)		Tolerance, ± (mm)	
	200228				Isaac Erskine		800		Greater Than	Less Than or Equal to		
	Description				Date Drawn		Material		0.00		0.40	
	Rectangle - Solid				10/08/2020		EPDM		1.50		0.50	
	Revision				Approved By		Hardness (Shore A)		2.50		0.70	
	A	Date of Issue		Sheet Scale		Isaac Erskine		70		4.00		0.80
		15/02/2022		1:1		15/02/2022		Black		6.30		1.00
				Sheet Size		Date of Approval		Colour		10.00		1.30
				A3		15/02/2022		Weight (kg/m)		16.00		1.60
				1/1		3rd Agl. 		1.008		25.00		2.00
									40.00		2.50	
									63.00		3.20	
									100.00		3.20%	

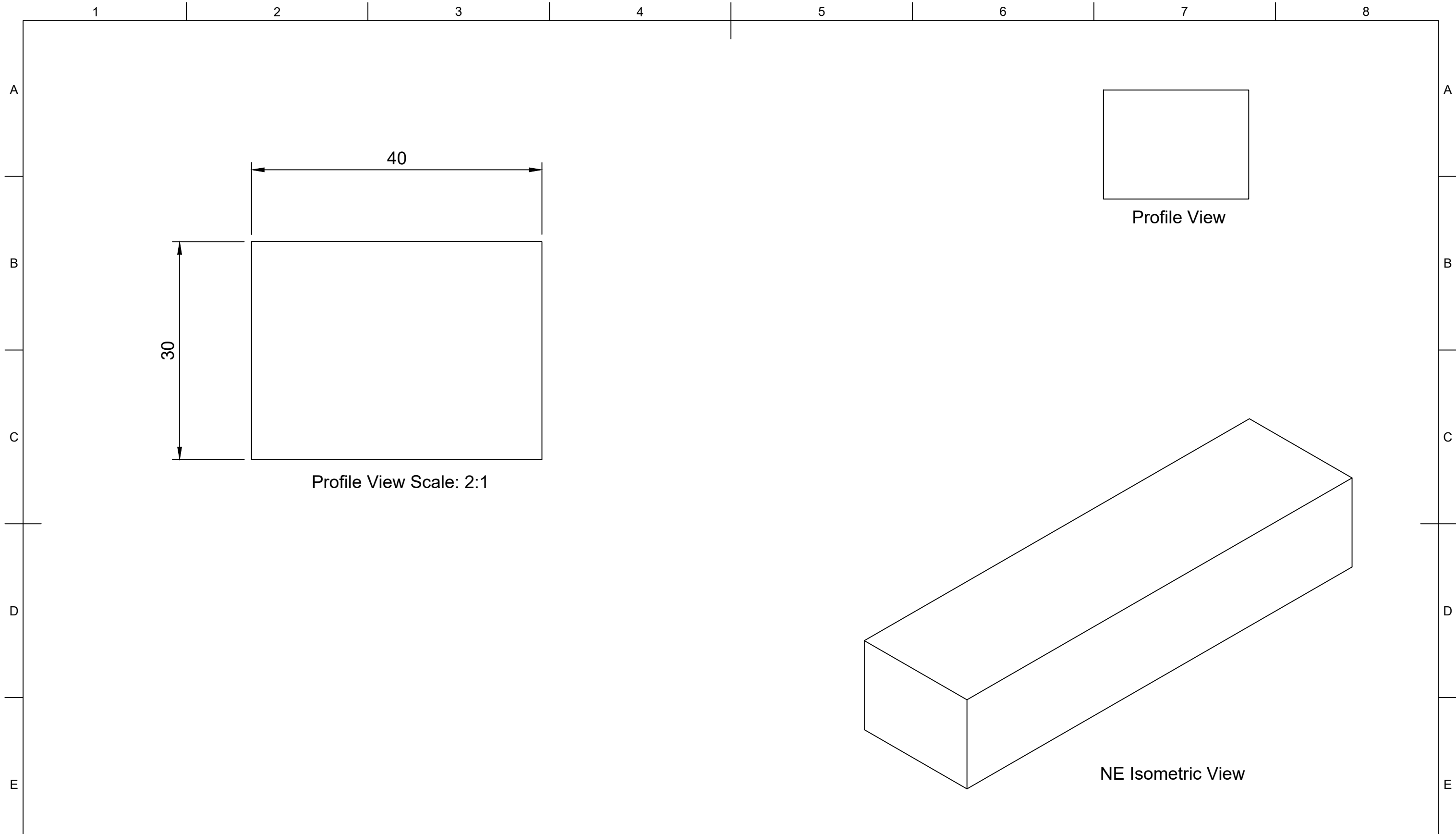

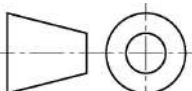
	Part Number				Created By		Cross Sectional Area (mm²)		Nominal Dimension (mm)		Tolerance, ± (mm)
	208822				Isaac Erskine		1200		Greater Than	Less Than or Equal to	
	Description				Date Drawn		Material		0.00	1.50	0.40
	Rectangle - Solid				10/08/2020		EPDM		1.50	2.50	0.50
	Revision				Approved By		Hardness (Shore A)		2.50	4.00	0.70
	A	15/02/2022			Isaac Erskine		70		4.00	6.30	0.80
	Date of Issue				Date of Approval		Colour		6.30	10.00	1.00
	15/02/2022				15/02/2022		Black		10.00	16.00	1.30
	Sheet Scale				Projection		Weight (kg/m)		16.00	25.00	1.60
	1:1				3rd Agl. 		1.512		25.00	40.00	2.00
Sheet Size								40.00	63.00	2.50	
A3								63.00	100.00	3.20	
Sheet								100.00		3.20%	
1/1											

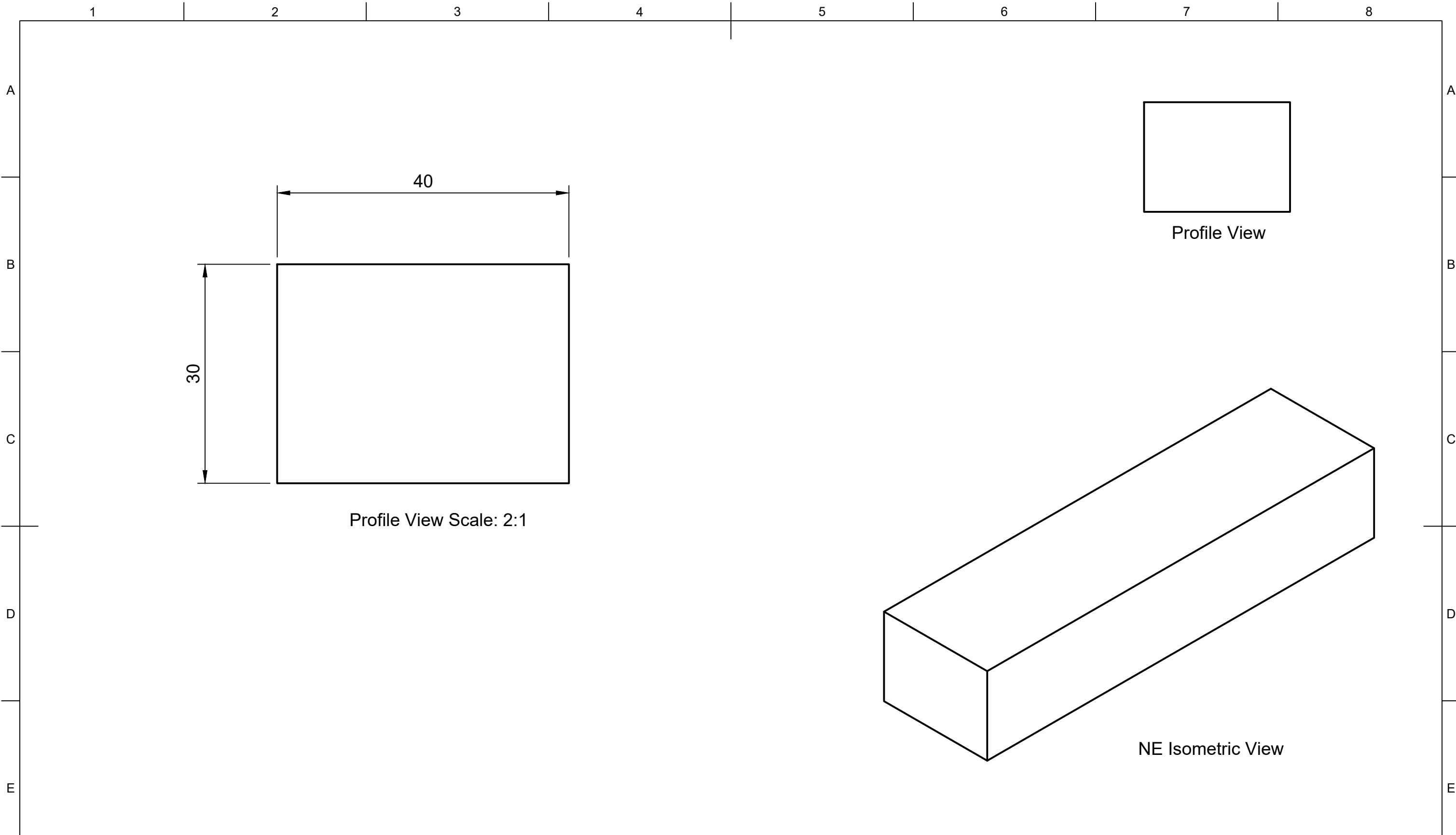

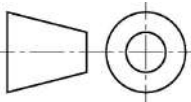
	Part Number				Created By		Cross Sectional Area (mm²)		Nominal Dimension (mm)		Tolerance, ± (mm)	
	200498				Isaac Erskine		1200		Greater Than	Less Than or Equal to		
	Description				Date Drawn		Material					
	Rectangle - Solid				15/02/2022		Nitrile				0.40	
					Approved By		Hardness (Shore A)				1.50	
					Isaac Erskine		70				2.50	
					Date of Approval		Colour				4.00	
					15/02/2022		Black				6.30	
					Projection		Weight (kg/m)				10.00	
					3rd Agl. 		1.452				16.00	
Revision	Date of Issue	Sheet Scale	Sheet Size	Sheet							25.00	
A	15/02/2022	1:1	A3	1/1							40.00	
												63.00
												100.00
												—
												3.20%

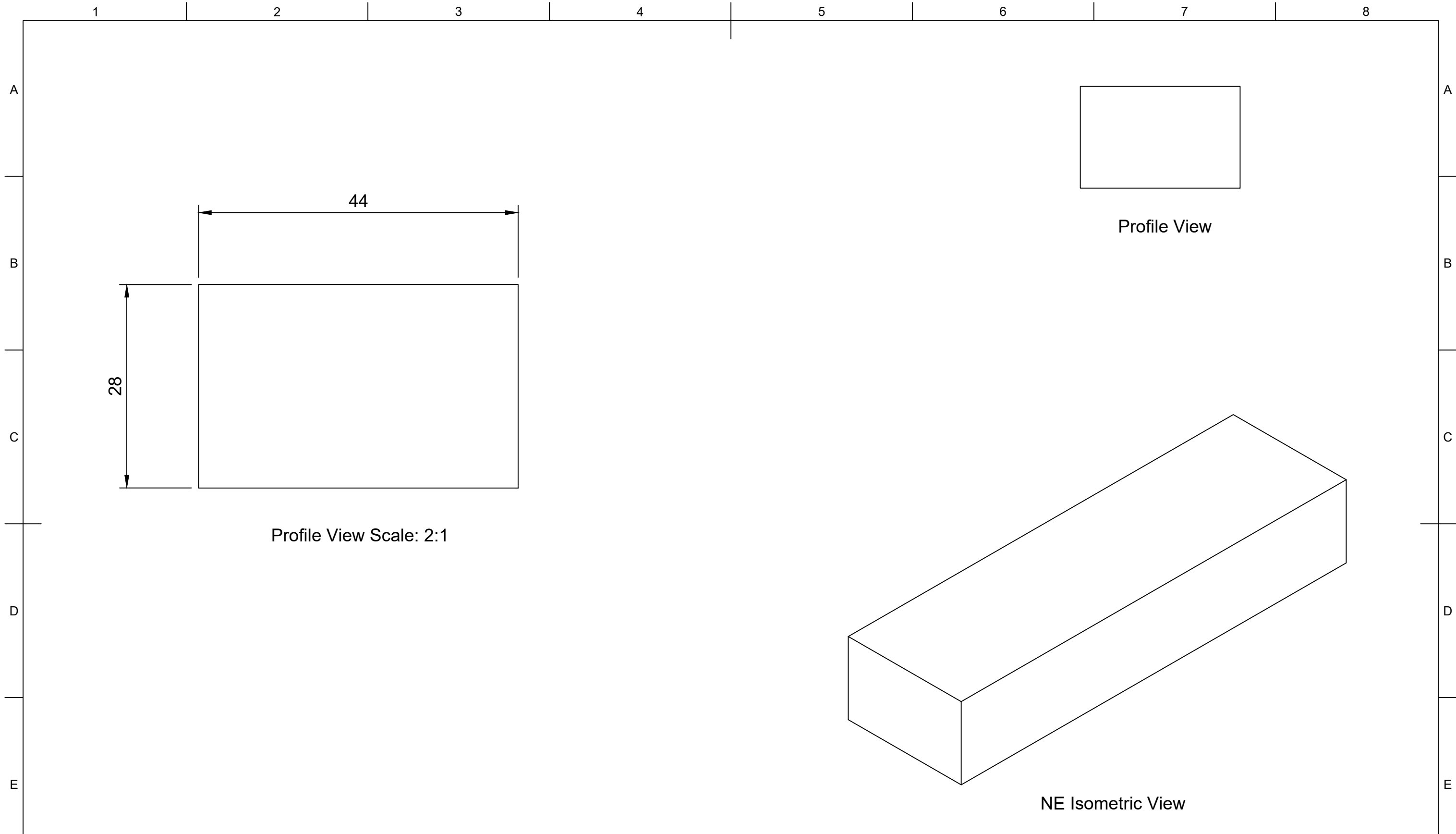

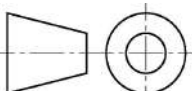
	Part Number				Created By		Cross Sectional Area (mm²)		Nominal Dimension (mm)		Tolerance, ± (mm)
	209092				Isaac Erskine		1232		Greater Than	Less Than or Equal to	
					Date Drawn		Material		0.00	1.50	0.40
					10/08/2020		EPDM		1.50	2.50	0.50
	Description				Approved By		Hardness (Shore A)		2.50	4.00	0.70
	Rectangle - Solid				Isaac Erskine		70		4.00	6.30	0.80
					Date of Approval		Colour		6.30	10.00	1.00
					15/02/2022		Black		10.00	16.00	1.30
							Weight (kg/m)		16.00	25.00	1.60
							3rd Agl.		25.00	40.00	2.00
Revision	Date of Issue	Sheet Scale	Sheet Size	Sheet			1.552		40.00	63.00	2.50
A	15/02/2022	1:1	A3	1/1					63.00	100.00	3.20
								100.00			3.20%

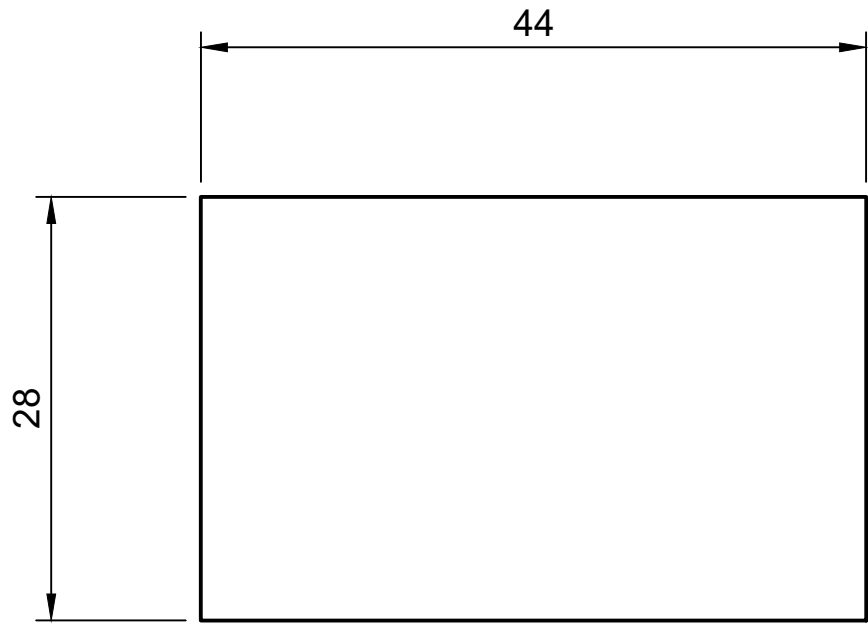
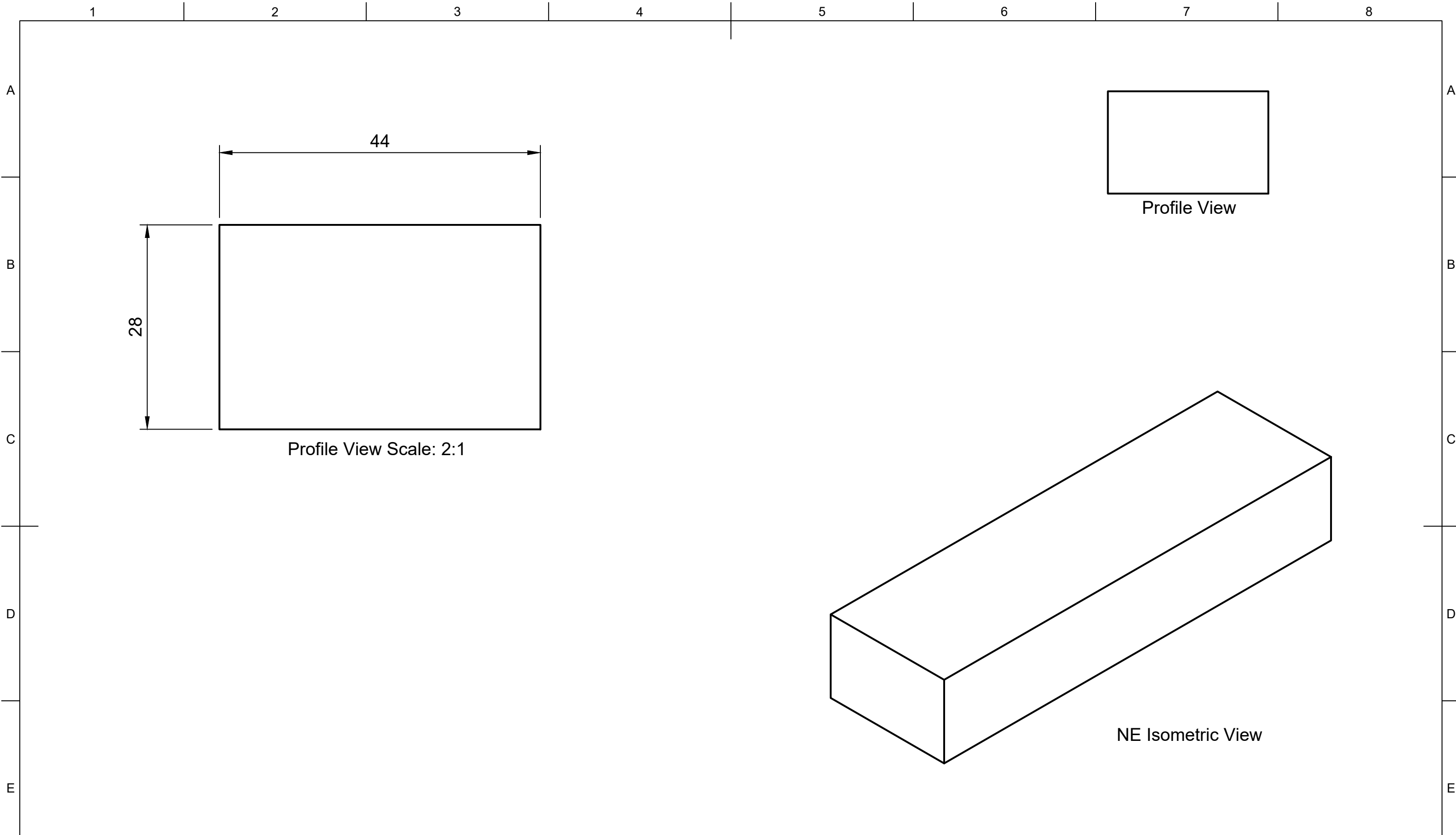

Profile View Scale: 2:1



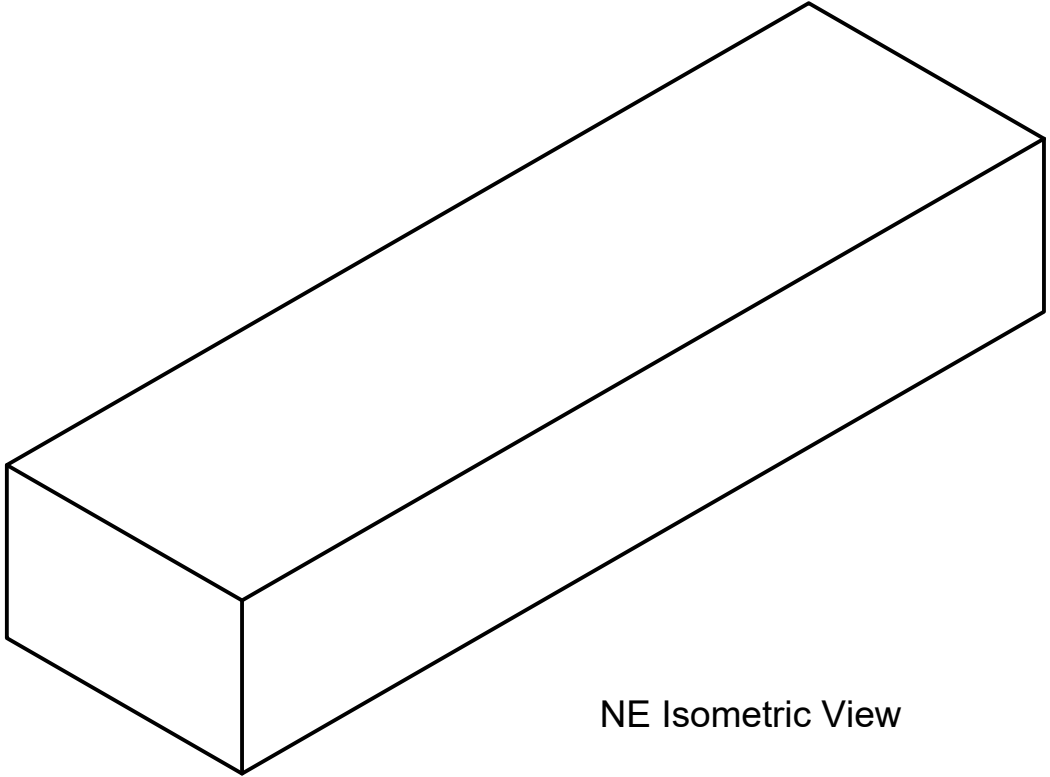

Profile View



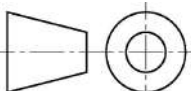

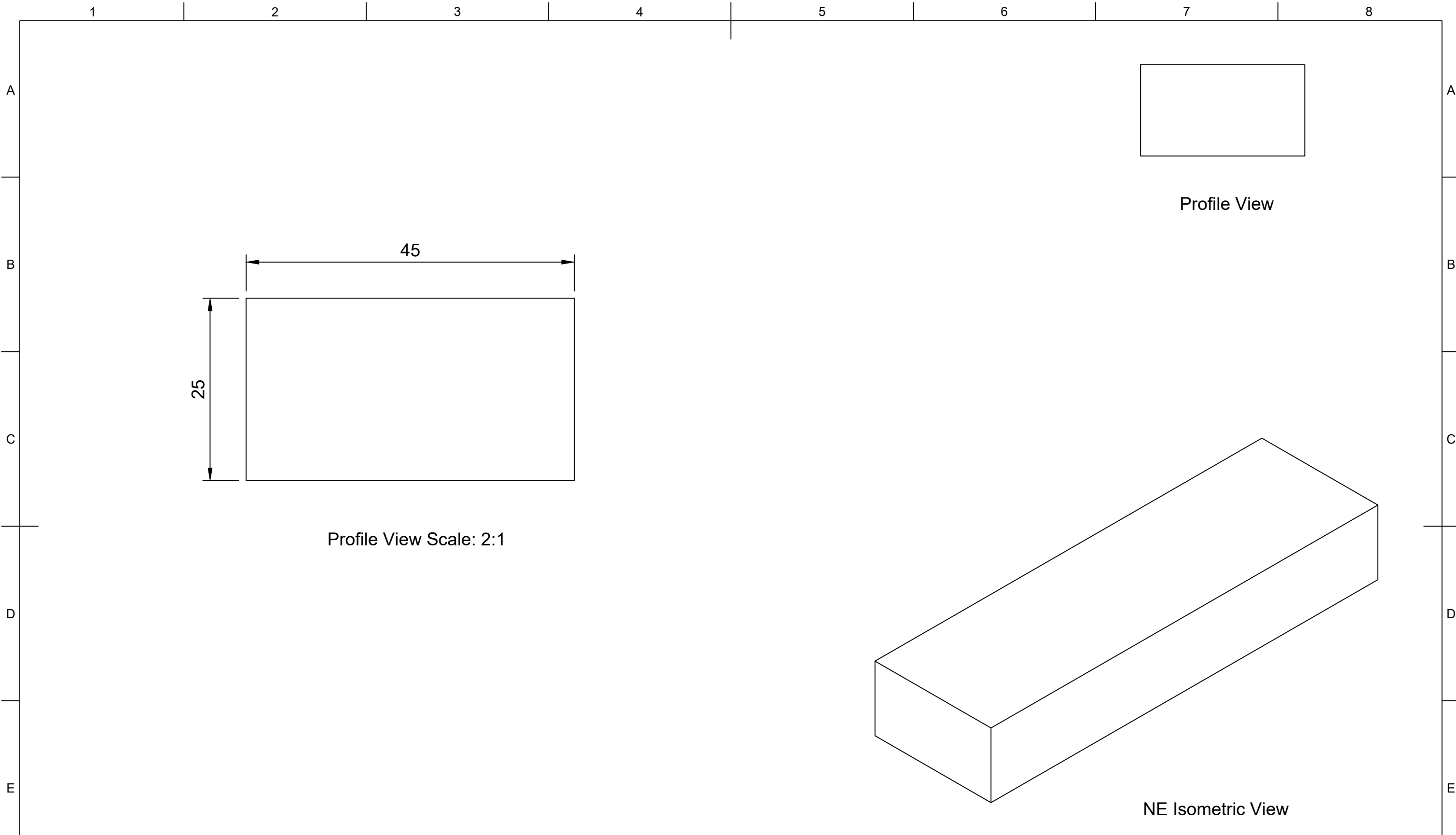
NE Isometric View

	Part Number				Created By		Cross Sectional Area (mm²)		Nominal Dimension (mm)		Tolerance, ± (mm)
	207532				Isaac Erskine		1232		Greater Than	Less Than or Equal to	
	Description				Date Drawn		Material		0.00		0.40
	Rectangle - Solid				15/02/2022		Neoprene		1.50		0.50
	Revision				Approved By		Hardness (Shore A)		2.50		0.70
	A	15/02/2022		Isaac Erskine		70		4.00		0.80	
	Date of Issue				Date of Approval		Colour		6.30		1.00
	15/02/2022				15/02/2022		Black		10.00		1.30
	Sheet Scale				Projection		Weight (kg/m)		16.00		1.60
	1:1				3rd Agl. 		1.873		25.00		2.00
Sheet Size								40.00		2.50	
A3								63.00		3.20	
Sheet								100.00		3.20%	
1/1											

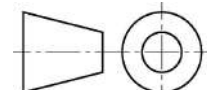

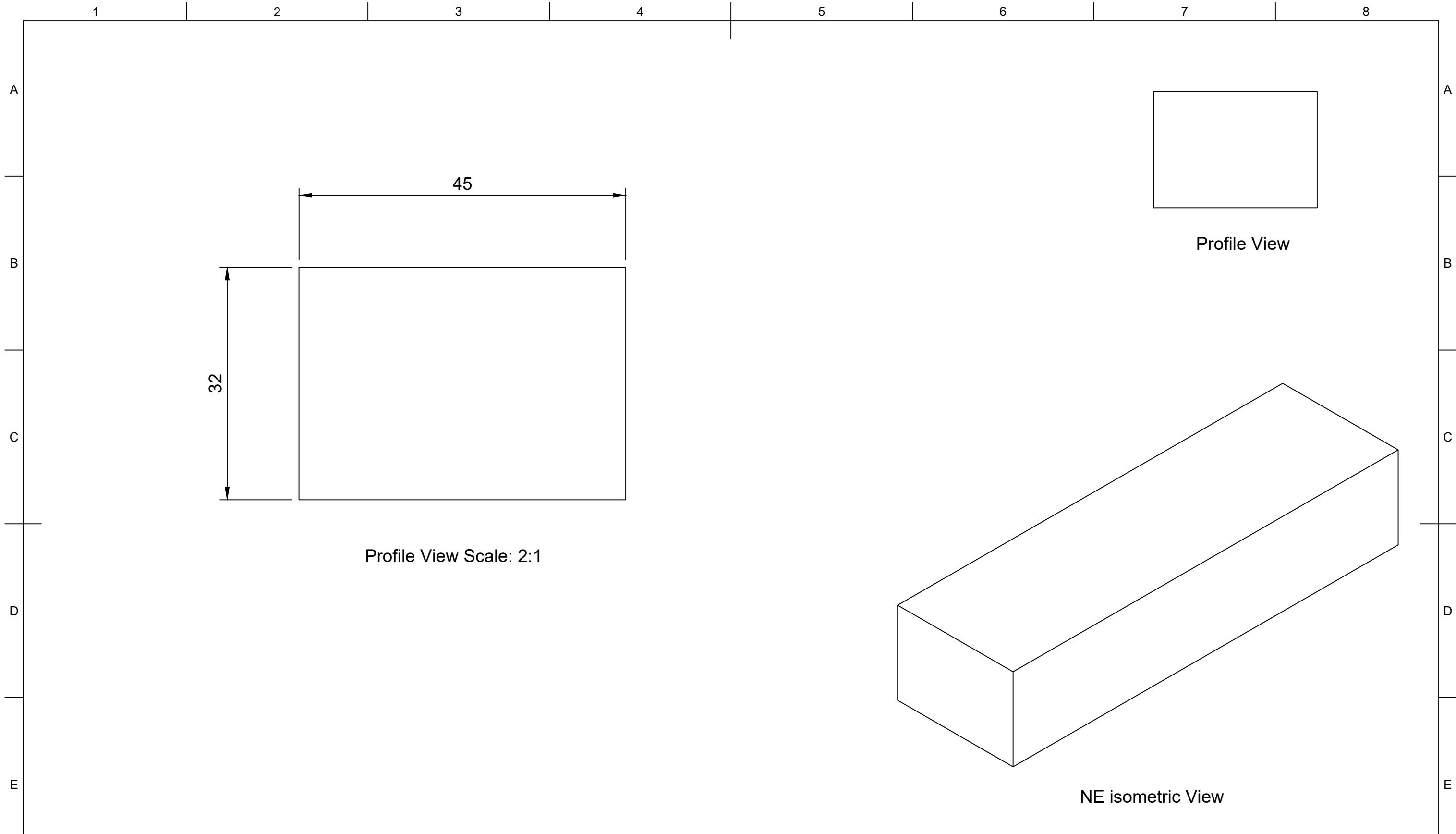
	Part Number				Created By		Cross Sectional Area (mm²)		Nominal Dimension (mm)		Tolerance, ± (mm)		
	208240				Isaac Erskine		1125		Greater Than	Less Than or Equal to			
	Description				Date Drawn		Material		0.00	1.50	0.40		
	Rectangle - Solid				10/08/2020		EPDM		1.50	2.50	0.50		
	Revision				Approved By		Hardness (Shore A)		2.50	4.00	0.70		
	A	Date of Issue		Sheet Scale		Sheet Size		Sheet		Date of Approval		Colour	
		16/02/2022		1:1		A3		1/1		16/02/2022		Black	
	Projection				Weight (kg/m)		3rd Agl.		1.418		4.00	6.30	0.80
											6.30	10.00	1.00
											10.00	16.00	1.30
										16.00	25.00	1.60	
										25.00	40.00	2.00	
										40.00	63.00	2.50	
										63.00	100.00	3.20	
										100.00		3.20%	

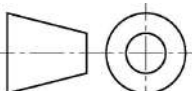

	Part Number				Created By		Cross Sectional Area (mm²)		Nominal Dimension (mm)		Tolerance, ± (mm)
	204129				Isaac Erskine		1440		Greater Than	Less Than or Equal to	
	Description				Date Drawn		Material				
	Rectangle - Solid				10/08/2020		EPDM				
	Revision				Approved By		Hardness (Shore A)				
	A	Date of Issue		Sheet Scale		Isaac Erskine		70			
		16/02/2022		1:1		16/02/2022		Black			
				Sheet Size		Date of Approval		Colour			
				A3		16/02/2022					
				Sheet		Projection		Weight (kg/m)			
			1/1		3rd Agl. 		1.814				
									25.00	40.00	2.00
									40.00	63.00	2.50
									63.00	100.00	3.20
									100.00		3.20%

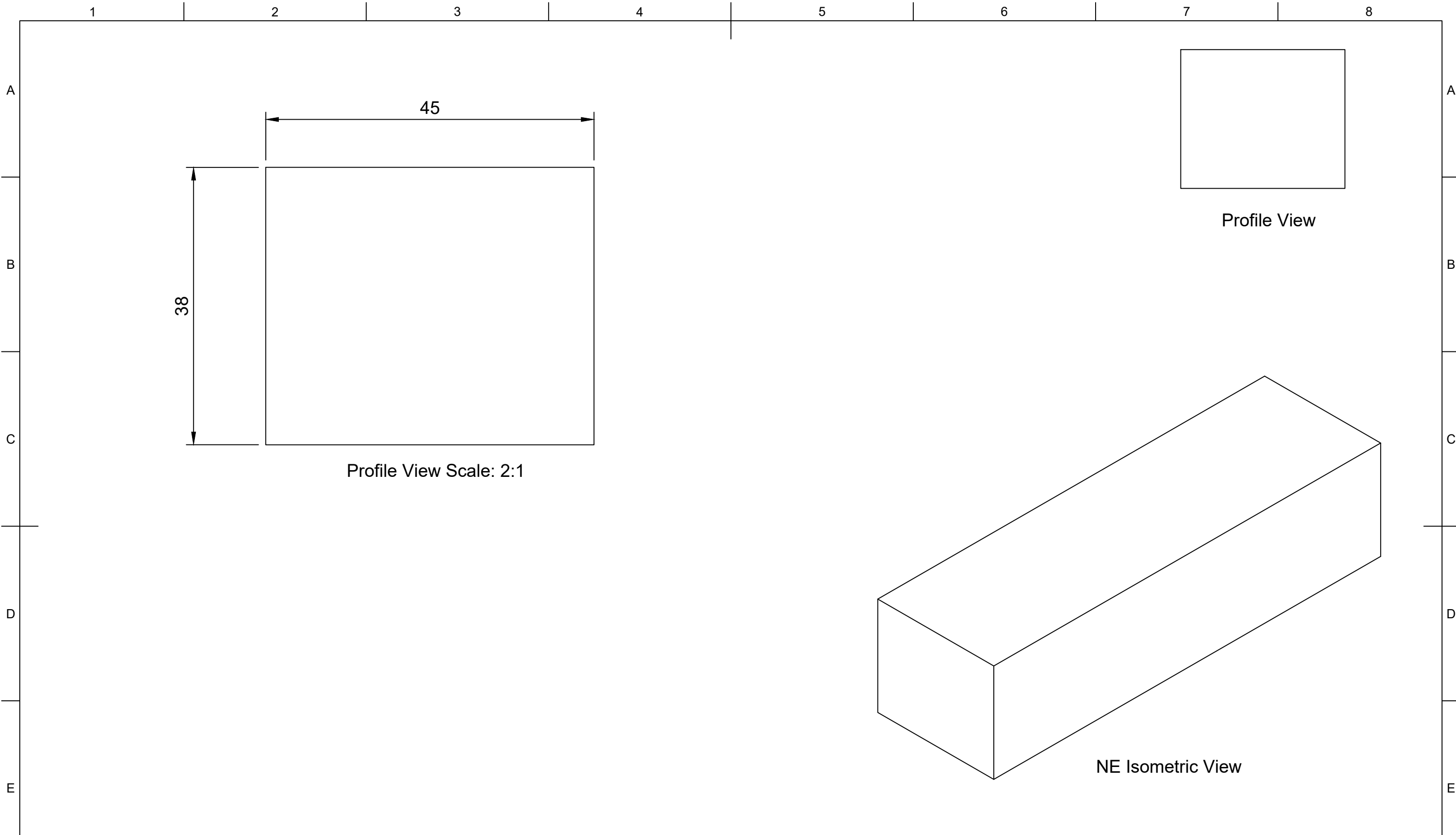

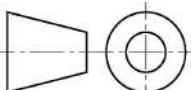
	Part Number				Created By		Cross Sectional Area (mm²)		Nominal Dimension (mm)		Tolerance, ± (mm)
	204386				Isaac Erskine		1710		Greater Than	Less Than or Equal to	
					Date Drawn		Material		0.00	1.50	0.40
					10/08/2020		EPDM		1.50	2.50	0.50
	Description				Approved By		Hardness (Shore A)		2.50	4.00	0.70
	Rectangle - Solid				Isaac Erskine		70		4.00	6.30	0.80
					Date of Approval		Colour		6.30	10.00	1.00
					16/02/2022		Black		10.00	16.00	1.30
									16.00	25.00	1.60
									25.00	40.00	2.00
Revision	Date of Issue	Sheet Scale	Sheet Size	Sheet	Projection	Weight (kg/m)		40.00	63.00	2.50	
A	16/02/2022	1:1	A3	1/1	3rd Agl. 	2.155		63.00	100.00	3.20	
								100.00		3.20%	

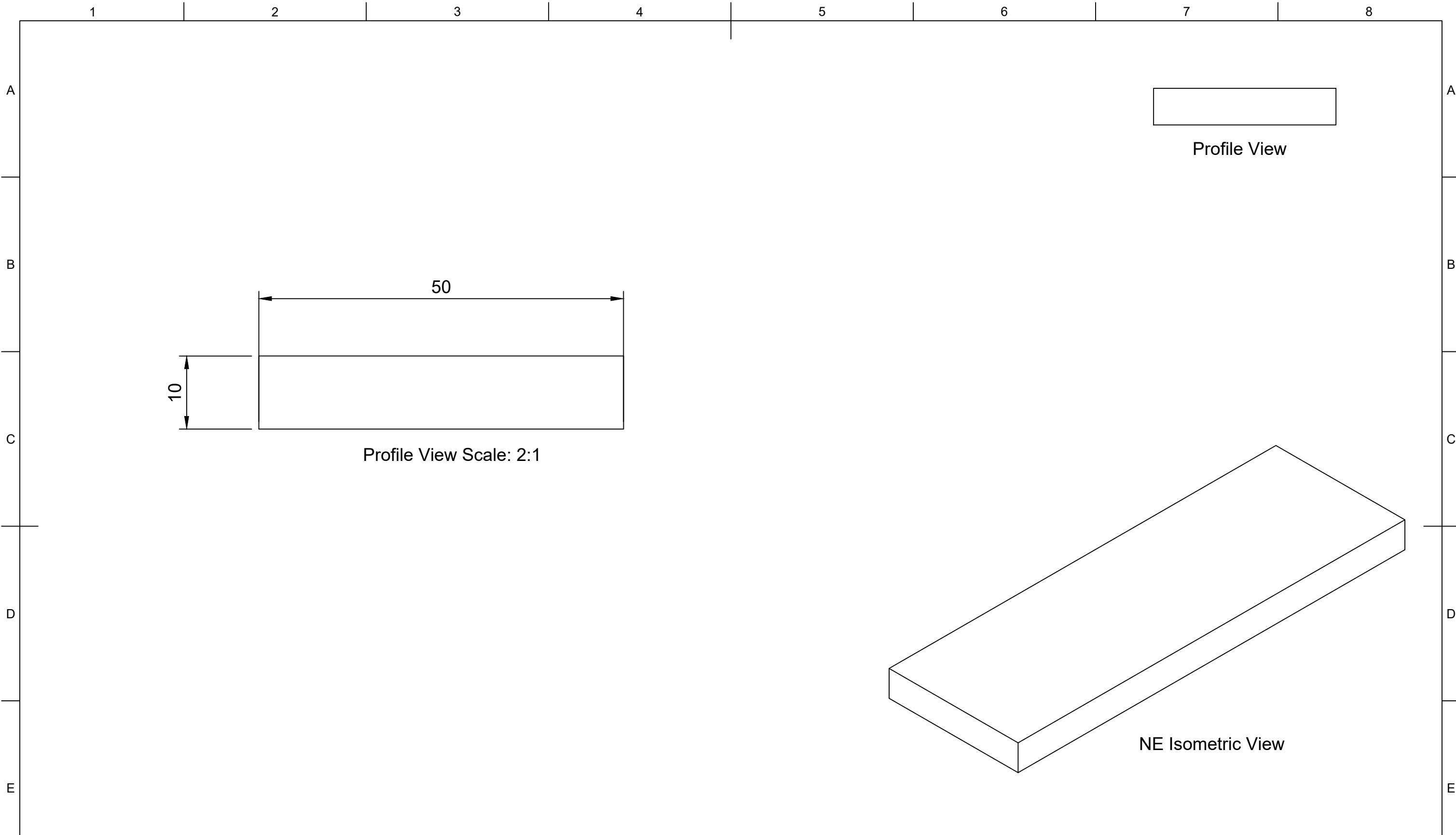

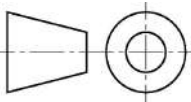
	Part Number				Created By		Cross Sectional Area (mm²)		Nominal Dimension (mm)		Tolerance, ± (mm)
	207006				Isaac Erskine		500		Greater Than	Less Than or Equal to	
	Description				Date Drawn		Material				
	Rectangle - Solid				11/11/2020		Nitrile				
					Approved By		Hardness (Shore A)				
					Isaac Erskine		70				
					Date of Approval		Colour				
					16/02/2022		Black				
					Projection		Weight (g/m)				
					3rd Agl. 		605				
Revision	Date of Issue	Sheet Scale	Sheet Size	Sheet							
A	16/02/2022	1:1	A3	1/1							
								25.00	40.00	2.00	
								40.00	63.00	2.50	
								63.00	100.00	3.20	
								100.00		3.20%	

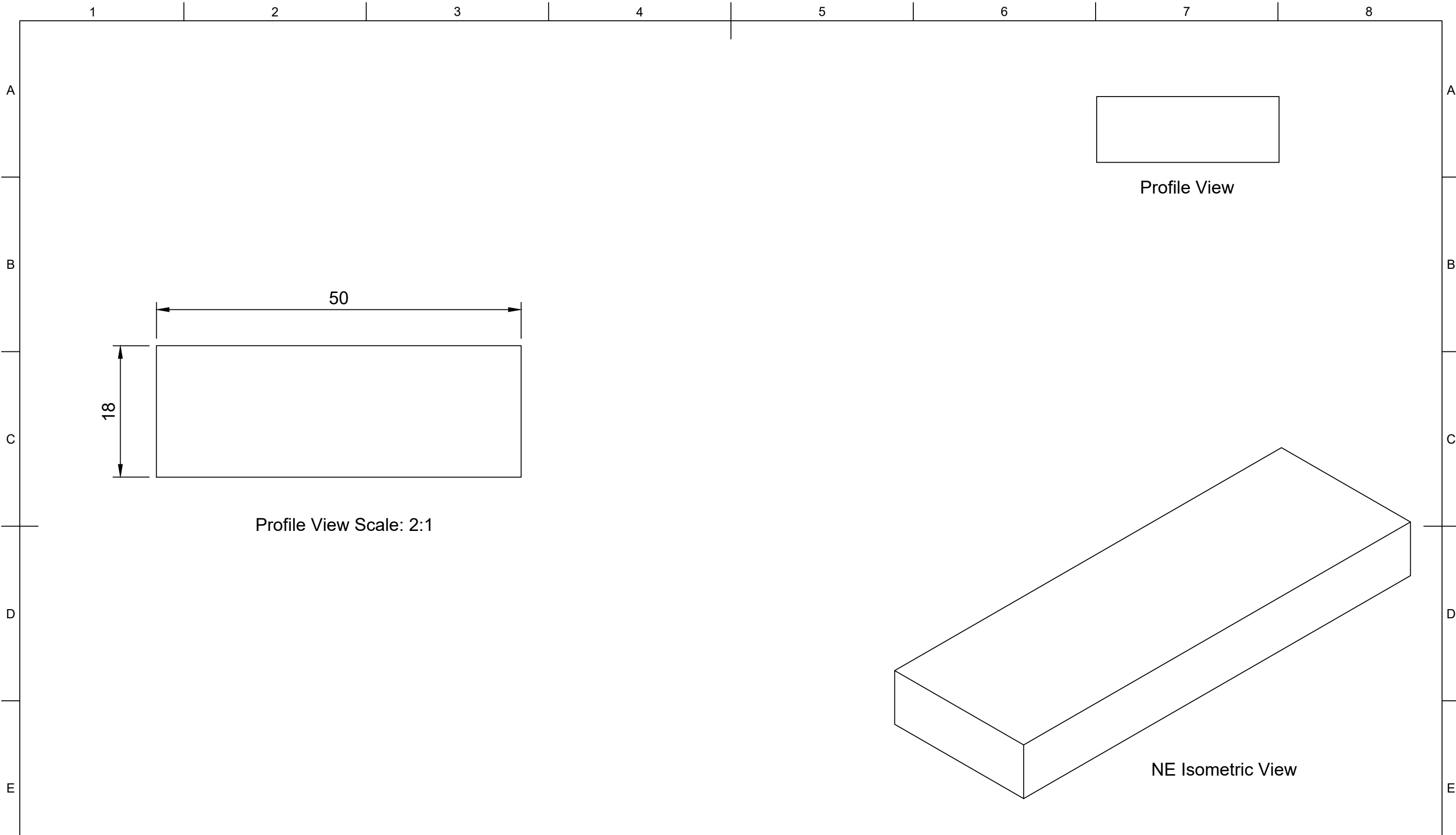

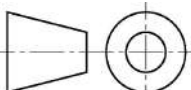
	Part Number				Created By		Cross Sectional Area (mm²)		Nominal Dimension (mm)		Tolerance, ± (mm)	
	209074				Isaac Erskine		900		Greater Than	Less Than or Equal to		
	Description				Date Drawn		Material		0.00		0.40	
	Rectangle - Solid				10/08/2020		EPDM		1.50		0.50	
	Revision				Approved By		Hardness (Shore A)		2.50		0.70	
	A	Date of Issue		Sheet Scale		Isaac Erskine		Colour		4.00		0.80
		16/02/2022		1:1		16/02/2022		Black		6.30		1.00
				Sheet Size		Date of Approval		Weight (kg/m)		10.00		1.30
				A3		16/02/2022		1.134		16.00		1.60
				Sheet		Projection				25.00		2.00
			1/1		3rd Agl. 				40.00		2.50	
									63.00		3.20	
									100.00		3.20%	

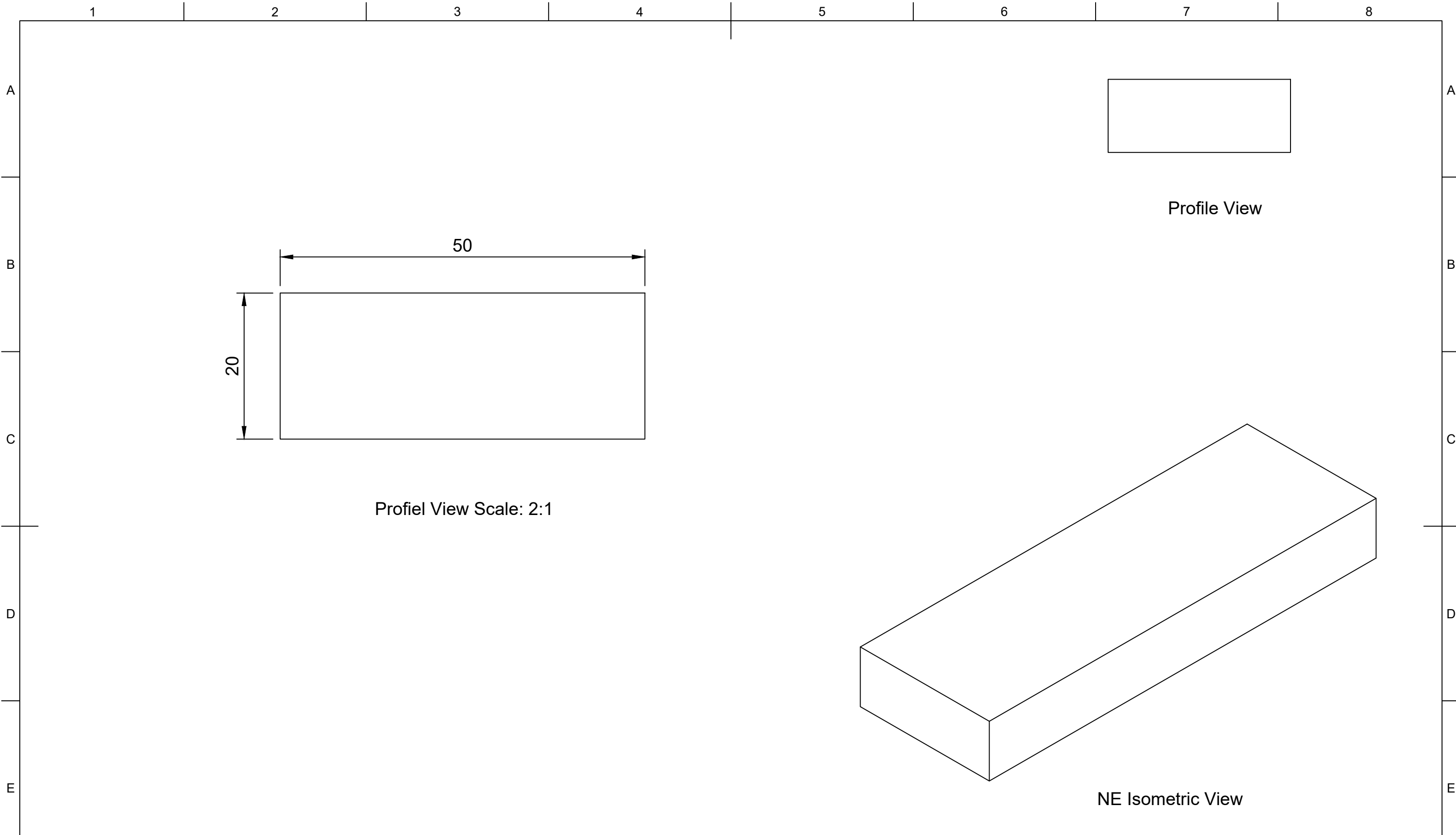

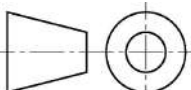
	Part Number				Created By		Cross Sectional Area (mm²)		Nominal Dimension (mm)		Tolerance, ± (mm)	
	206172				Isaac Erskine		1000		Greater Than	Less Than or Equal to		
	Description				Date Drawn		Material		0.00	1.50	0.40	
	Rectangle - Solid				10/08/2020		EPDM		1.50	2.50	0.50	
	Revision				Approved By		Hardness (Shore A)		2.50	4.00	0.70	
	A	16/02/2022		1:1	Isaac Erskine		70		4.00	6.30	0.80	
	Date of Issue		Sheet Scale	Sheet Size	Sheet	Date of Approval		Colour		6.30	10.00	1.00
	16/02/2022		1:1	A3	1/1	16/02/2022		Black		10.00	16.00	1.30
	Projection				3rd Agl.		Weight (kg/m)		16.00	25.00	1.60	
							1.260		25.00	40.00	2.00	
								40.00	63.00	2.50		
								63.00	100.00	3.20		
								100.00		3.20%		

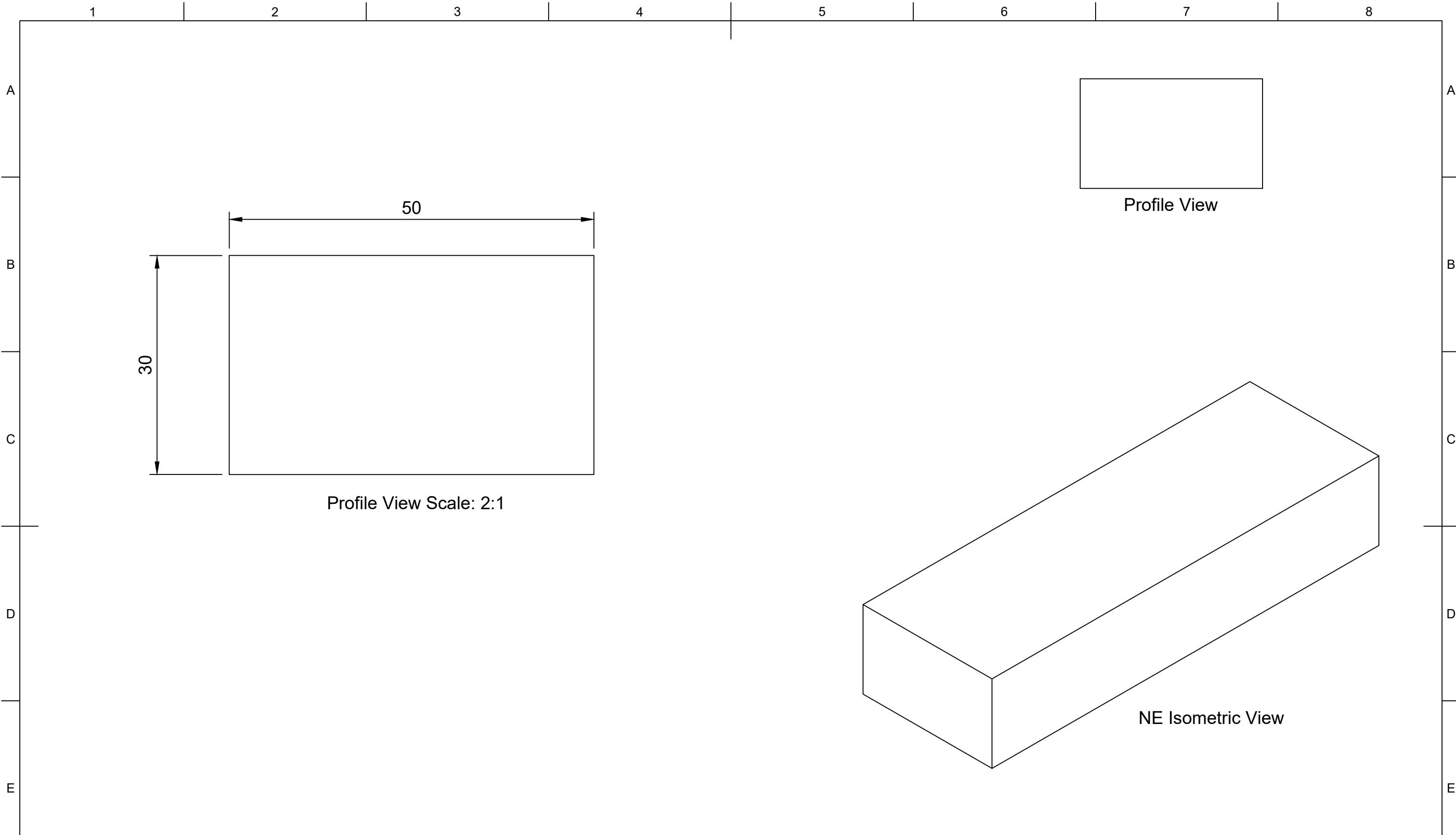

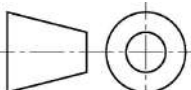
	Part Number				Created By		Cross Sectional Area (mm²)		Nominal Dimension (mm)		Tolerance, ± (mm)
	208089				Isaac Erskine		1500		Greater Than	Less Than or Equal to	
	Description				Date Drawn		Material				
	Rectangle - Solid				10/08/2020		EPDM				
					Approved By		Hardness (Shore A)				
					Isaac Erskine		70				
					Date of Approval		Colour				
					16/02/2022		Black				
					Projection		Weight (kg/m)				
					3rd Agl. 		1.890				
Revision	Date of Issue	Sheet Scale	Sheet Size	Sheet							
A	16/02/2022	1:1	A3	1/1							

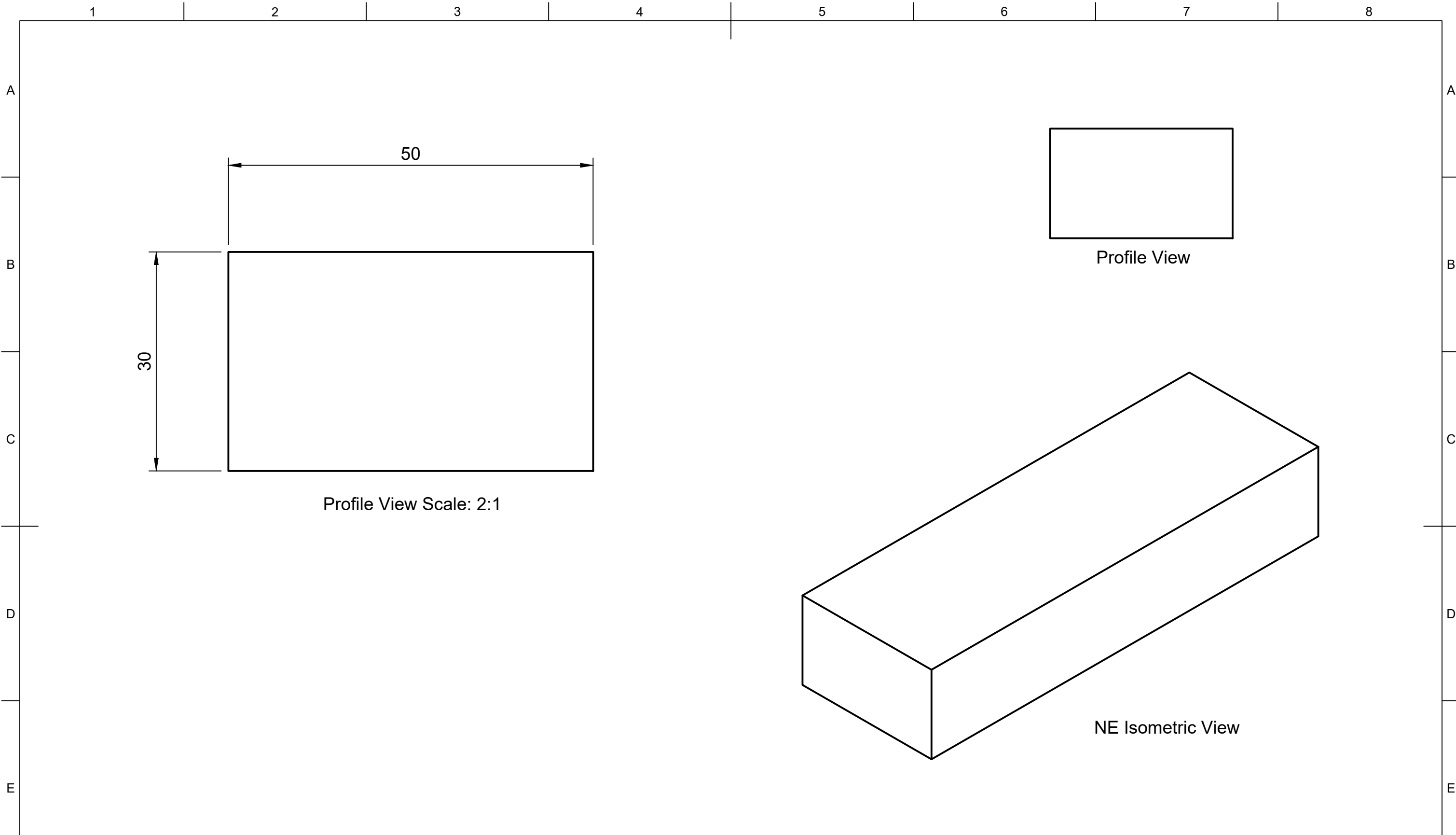

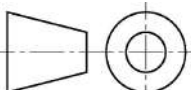
	Part Number				Created By		Cross Sectional Area (mm²)		Nominal Dimension (mm)		Tolerance, ± (mm)	
	209810				Isaac Erskine		1500		Greater Than	Less Than or Equal to		
	Description				Date Drawn		Material					
	Rectangle - Solid				16/02/2022		Nitrile				0.40	
	Revision				Approved By		Hardness (Shore A)				1.50	
	A	Date of Issue		Sheet Scale		Isaac Erskine		70				2.50
		16/02/2022		1:1		16/02/2022		Black				4.00
				Sheet Size		Date of Approval		Colour				6.30
				A3		16/02/2022						10.00
				Sheet		Projection		Weight (kg/m)				16.00
			1/1		3rd Agl. 		1.815				25.00	
											40.00	
											63.00	
											100.00	
											3.20%	

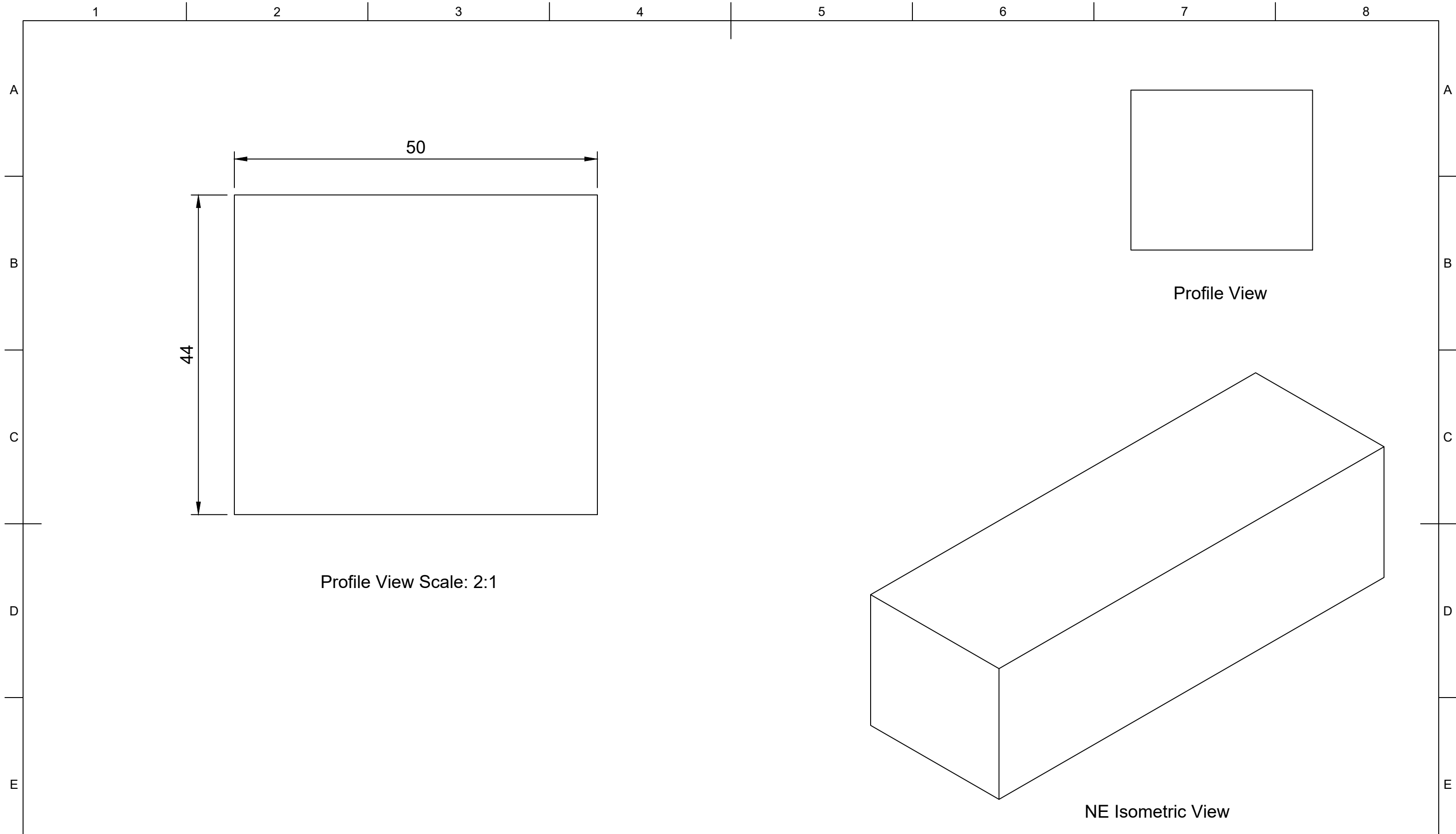

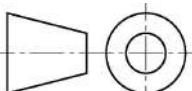
	Part Number				Created By		Cross Sectional Area (mm²)		Nominal Dimension (mm)		Tolerance, ± (mm)
	206982				Isaac Erskine		2200		Greater Than	Less Than or Equal to	
	Description				Date Drawn		Material		0.00	1.50	0.40
	Rectangle - Solid				10/08/2020		Nitrile		1.50	2.50	0.50
	Revision				Approved By		Hardness (Shore A)		2.50	4.00	0.70
	A	16/02/2022		Isaac Erskine		70		4.00	6.30	0.80	
	Date of Issue		Sheet Scale		Date of Approval		Colour		6.30	10.00	1.00
	16/02/2022		1:1		16/02/2022		Black		10.00	16.00	1.30
	Sheet Size		Sheet		Projection		Weight (kg/m)		16.00	25.00	1.60
	A3		1/1		3rd Agl. 		2.662		25.00	40.00	2.00
								40.00	63.00	2.50	
								63.00	100.00	3.20	
								100.00		3.20%	

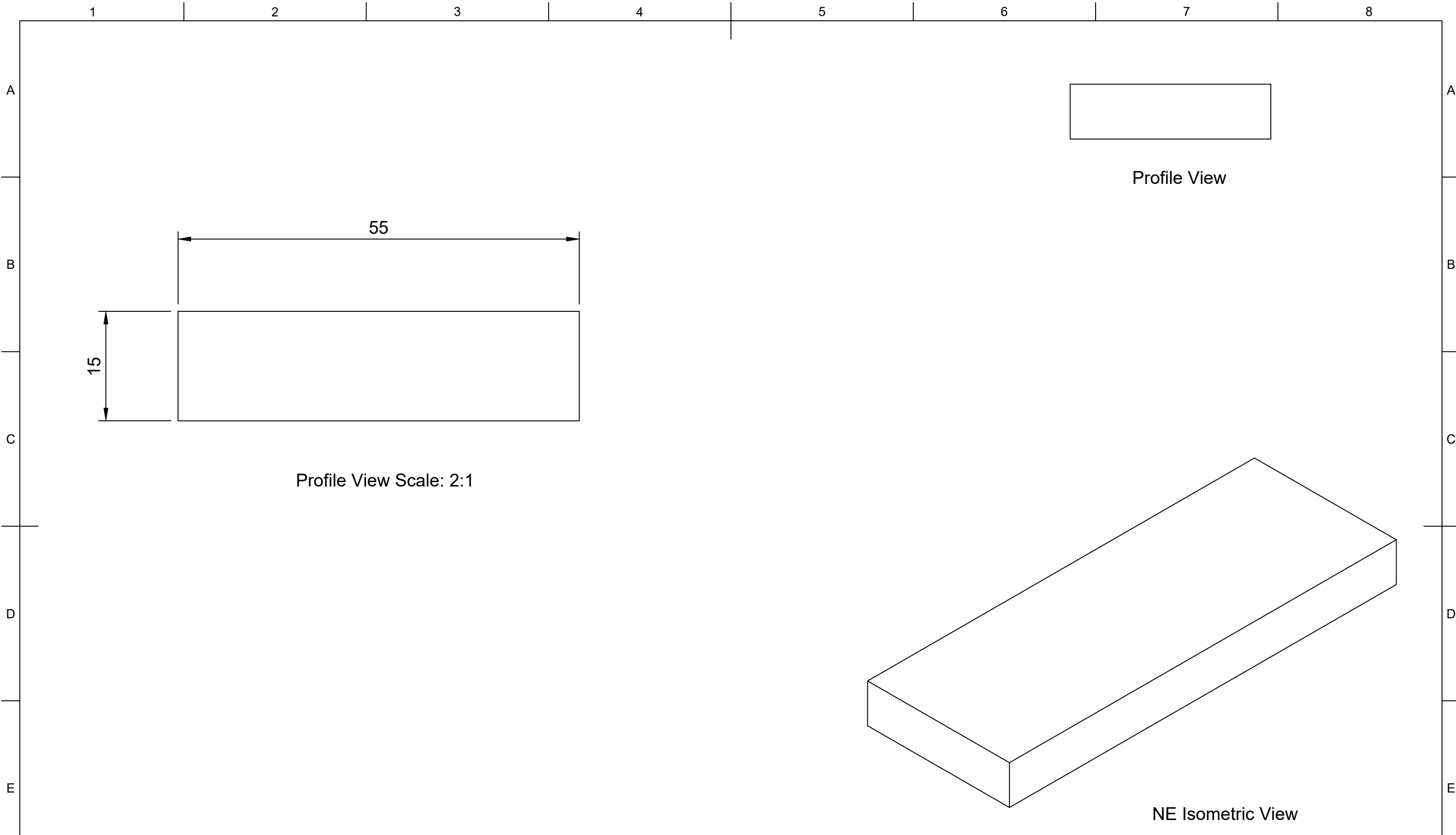

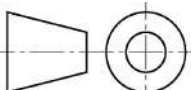

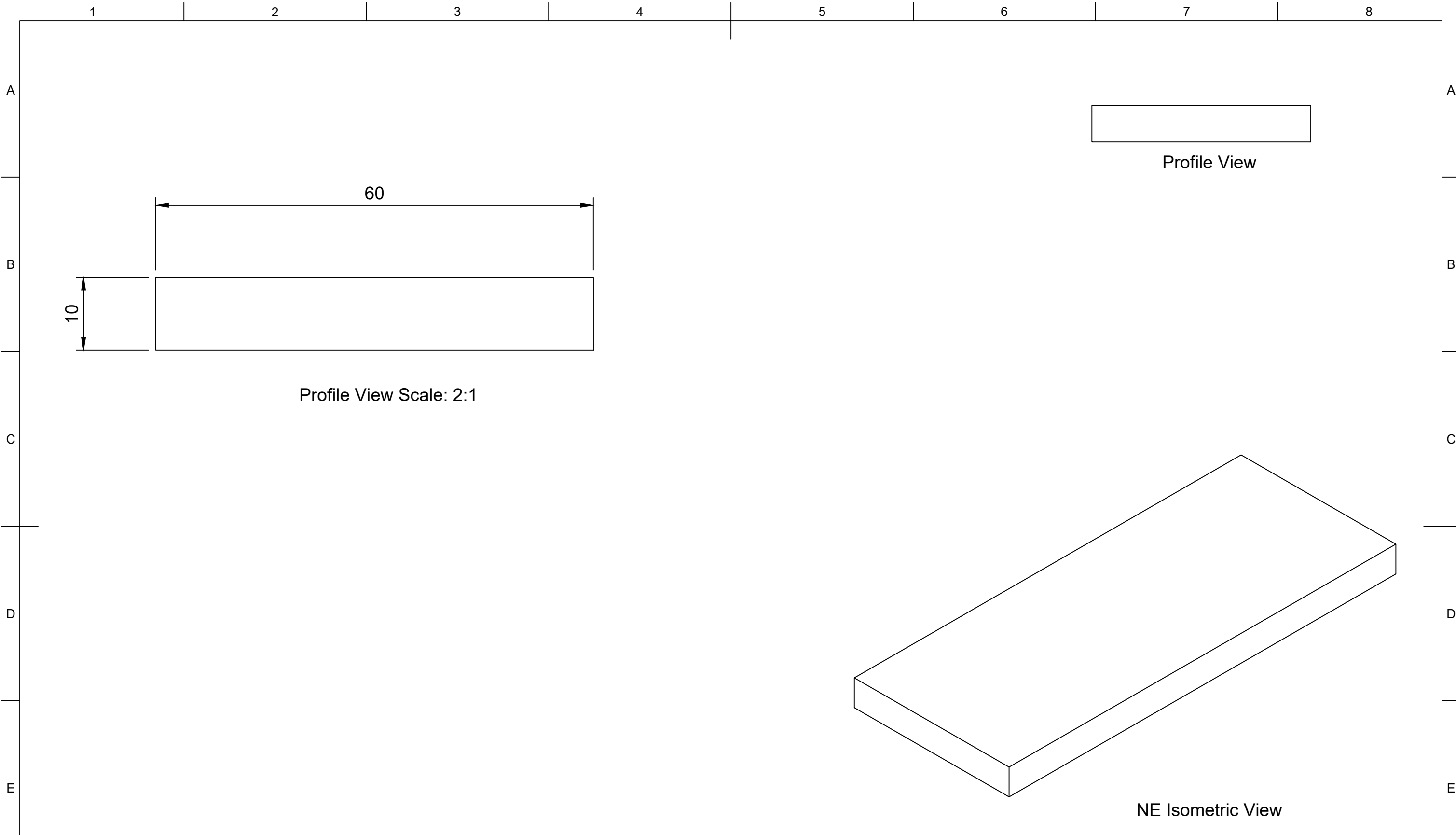
	Part Number				Created By		Cross Sectional Area (mm²)		Nominal Dimension (mm)		Tolerance, ± (mm)
	207381				Isaac Erskine		825		Greater Than	Less Than or Equal to	
					Date Drawn		Material		0.00	1.50	0.40
					11/08/2020		Nitrile		1.50	2.50	0.50
	Description				Approved By		Hardness (Shore A)		2.50	4.00	0.70
	Rectangle - Solid				Isaac Erskine		70		4.00	6.30	0.80
					Date of Approval		Colour		6.30	10.00	1.00
					16/02/2022		Black		10.00	16.00	1.30
							Weight (g/m)		16.00	25.00	1.60
							998		25.00	40.00	2.00
Revision	Date of Issue	Sheet Scale	Sheet Size	Sheet	Projection			40.00	63.00	2.50	
A	16/02/2022	1:1	A3	1/1	3rd Agl. 			63.00	100.00	3.20	
								100.00		3.20%	

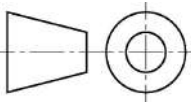

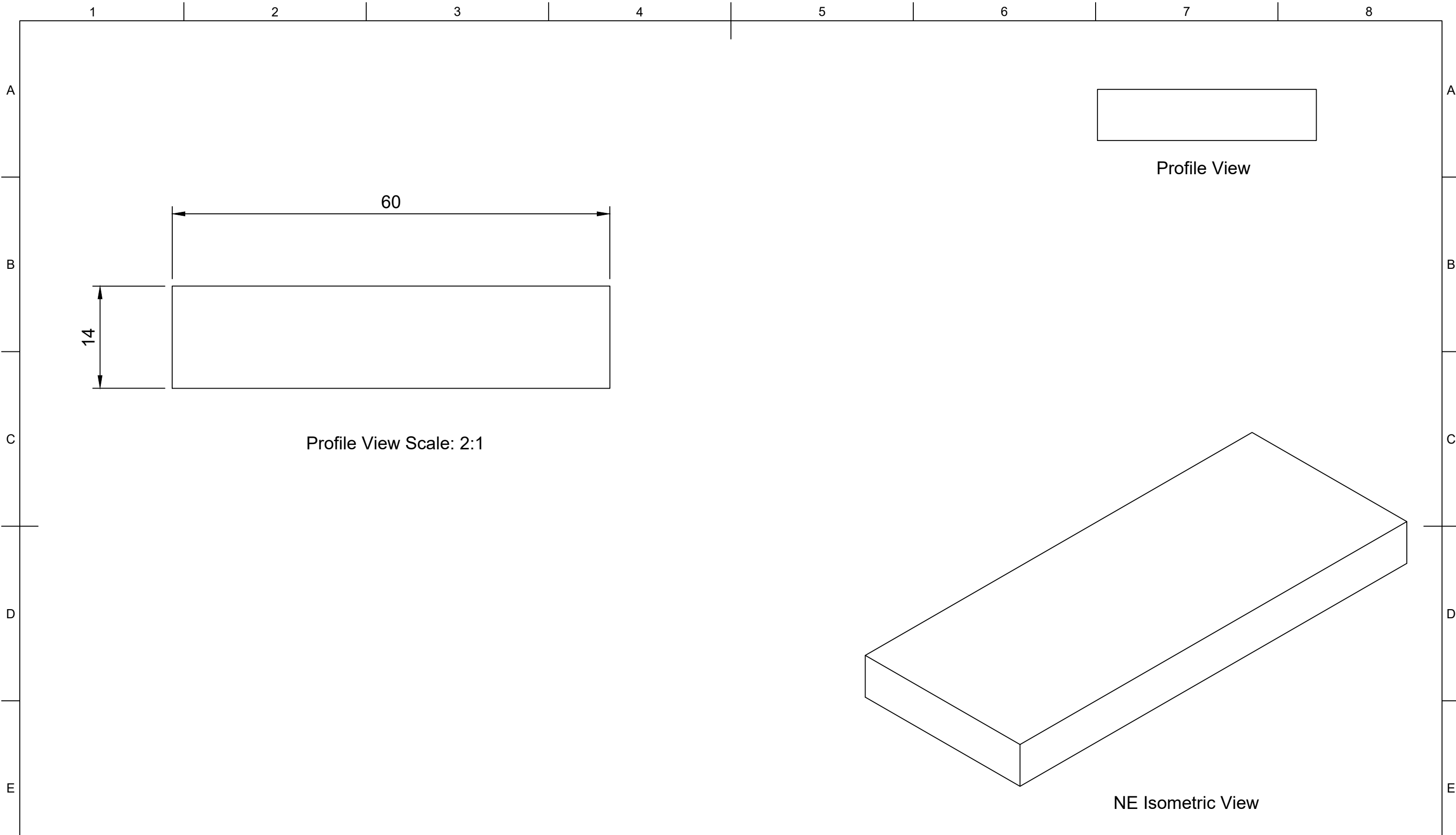

	Part Number				Created By		Cross Sectional Area (mm²)		Nominal Dimension (mm)		Tolerance, ± (mm)
	206091				Isaac Erskine		600		Greater Than	Less Than or Equal to	
					Date Drawn		Material		0.00	1.50	0.40
					11/08/2020		EPDM		1.50	2.50	0.50
	Description				Approved By		Hardness (Shore A)		2.50	4.00	0.70
	Rectangle - Solid				Isaac Erskine		70		4.00	6.30	0.80
					Date of Approval		Colour		6.30	10.00	1.00
					16/02/2022		Black		10.00	16.00	1.30
							Weight (g/m)		16.00	25.00	1.60
							756		25.00	40.00	2.00
Revision	Date of Issue	Sheet Scale	Sheet Size	Sheet	Projection			40.00	63.00	2.50	
A	16/02/2022	1:1	A3	1/1	3rd Agl.			63.00	100.00	3.20	
								100.00		3.20%	

1 2 3 4 5 6 7 8

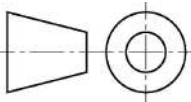

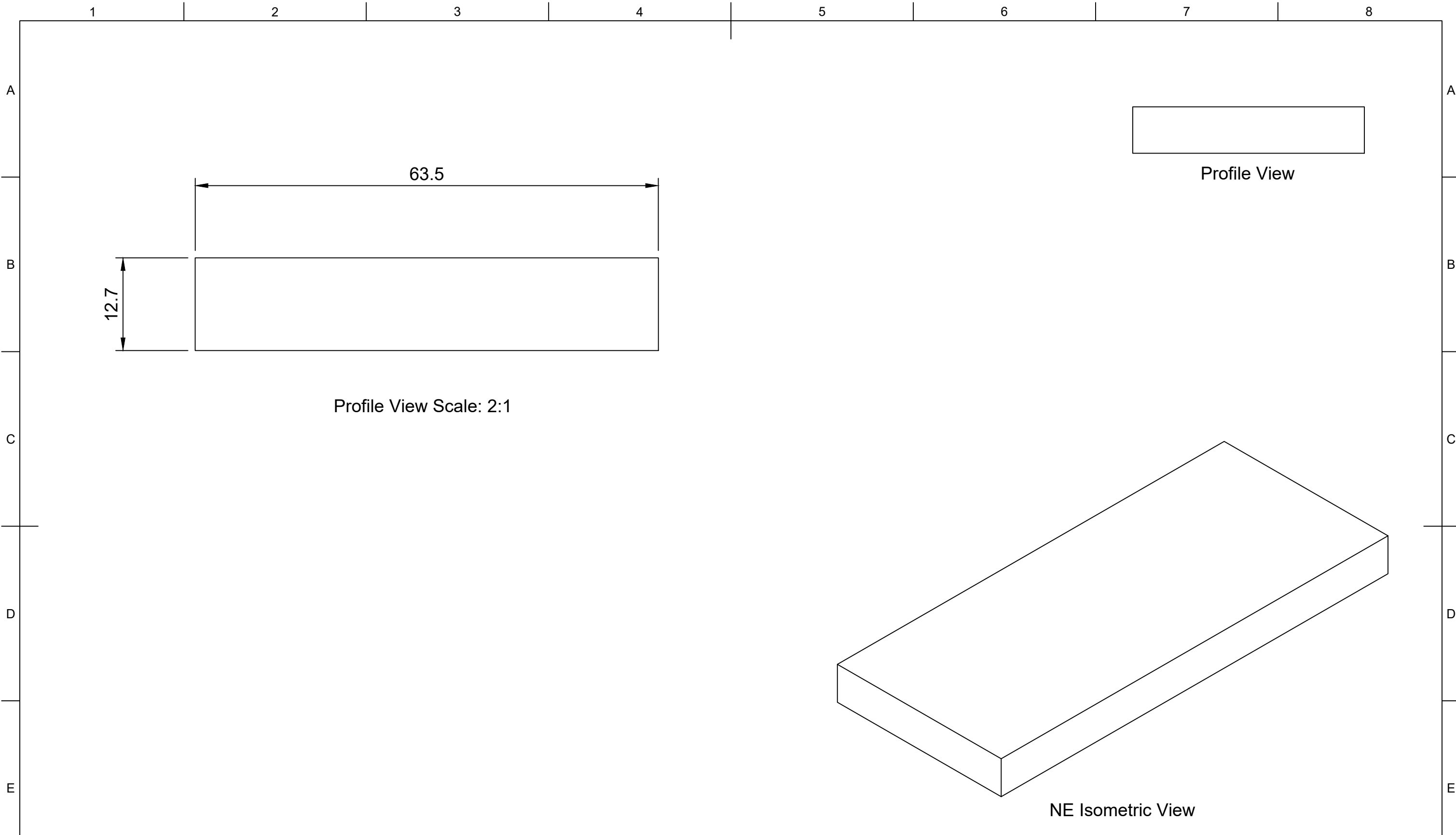
	Part Number				Created By		Cross Sectional Area (mm²)		Nominal Dimension (mm)		Tolerance, ± (mm)	
	202217				Isaac Erskine		840		Greater Than	Less Than or Equal to		
	Description				Date Drawn		Material		0.00		0.40	
	Rectangle - Solid				11/08/2020		EPDM		1.50		0.50	
	Revision				Approved By		Hardness (Shore A)		2.50		0.70	
	A	Date of Issue		Sheet Scale		Isaac Erskine		70		4.00		0.80
		16/02/2022		1:1		16/02/2022		Black		6.30		1.00
				Sheet Size		Date of Approval		Colour		10.00		1.30
				A3		16/02/2022				16.00		1.60
				Sheet		Projection		Weight (kg/m)		25.00		2.00
			1/1		3rd Agl. 		1.058		40.00		2.50	
									63.00		3.20	
									100.00		3.20%	

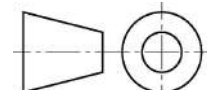

	Part Number				Created By		Cross Sectional Area (mm²)		Nominal Dimension (mm)		Tolerance, ± (mm)
	208345				Isaac Erskine		806		Greater Than	Less Than or Equal to	
	Description				Date Drawn		Material		0.00	1.50	0.40
	Rectangle - Solid				11/08/2020		EPDM		1.50	2.50	0.50
	Revision				Approved By		Hardness (Shore A)		2.50	4.00	0.70
	A	16/02/2022		1:1	A3	1/1	Isaac Erskine		4.00	6.30	0.80
	Date of Issue		Sheet Scale		Sheet Size		Date of Approval		6.30	10.00	1.00
	16/02/2022		1:1		A3		16/02/2022		10.00	16.00	1.30
	Projection		Sheet		Weight (kg/m)		3rd Agl.		16.00	25.00	1.60
	3rd Agl.		1/1		1.016				25.00	40.00	2.00
								40.00	63.00	2.50	
								63.00	100.00	3.20	
								100.00		3.20%	

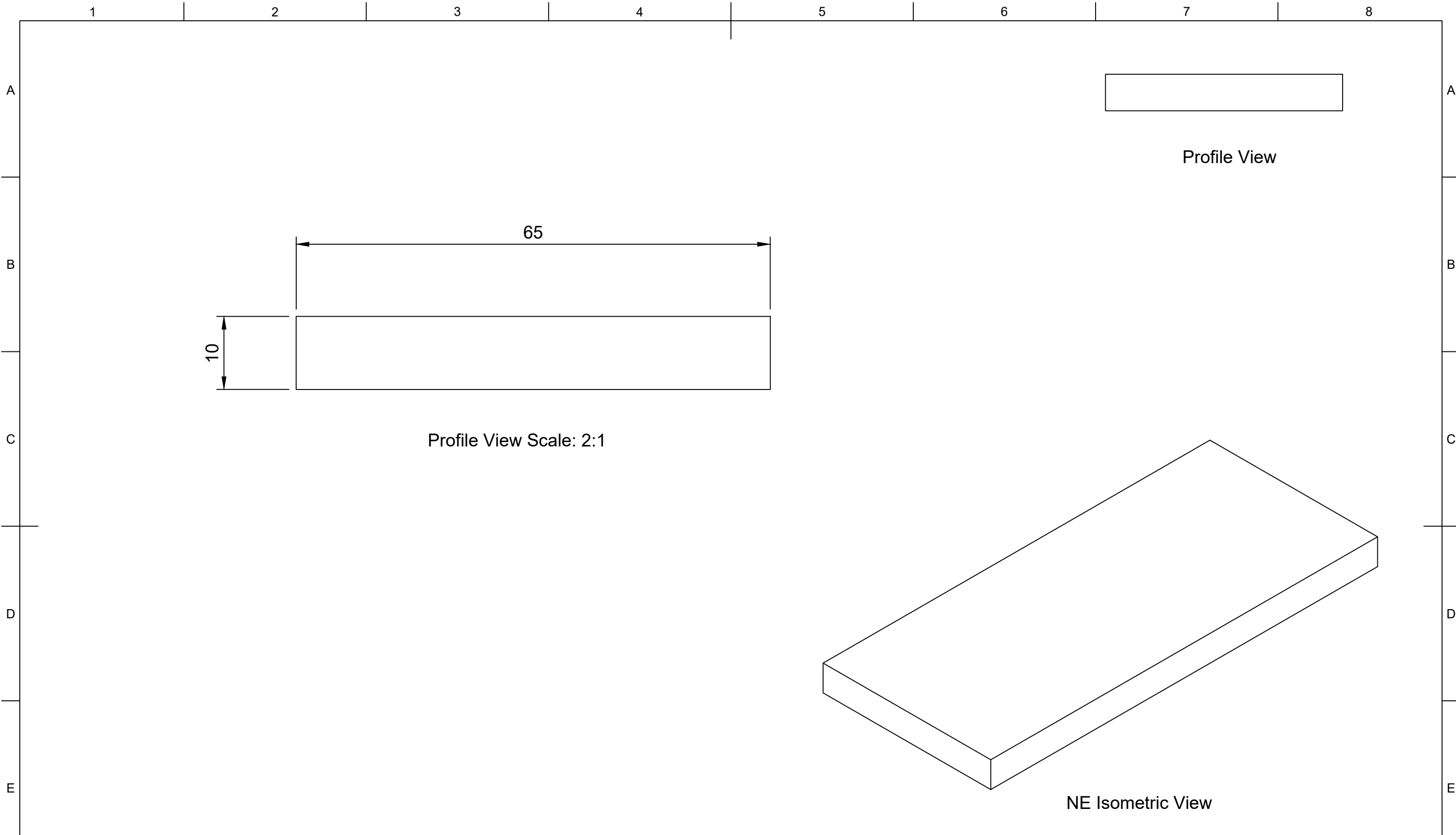

WALKERRUBBER LTD	Part Number				Created By		Cross Sectional Area (mm²)		Nominal Dimension (mm)		Tolerance, ± (mm)
	203231				Isaac Erskine		650		Greater Than	Less Than or Equal to	
	Description				Date Drawn		Material		0.00	1.50	0.40
	Rectangle - Solid				11/08/2020		Nitrile		1.50	2.50	0.50
	Revision				Approved By		Hardness (Shore A)		2.50	4.00	0.70
	A	16/02/2022		Isaac Erskine		70		4.00	6.30	0.80	
	Date of Issue		Sheet Scale		Date of Approval		Colour		6.30	10.00	1.00
	16/02/2022		1:1		16/02/2022		Black		10.00	16.00	1.30
	Sheet Size		Sheet		Projection		Weight (g/m)		16.00	25.00	1.60
	A3		1/1		3rd Agl.		787		25.00	40.00	2.00
								40.00	63.00	2.50	
								63.00	100.00	3.20	
								100.00		3.20%	

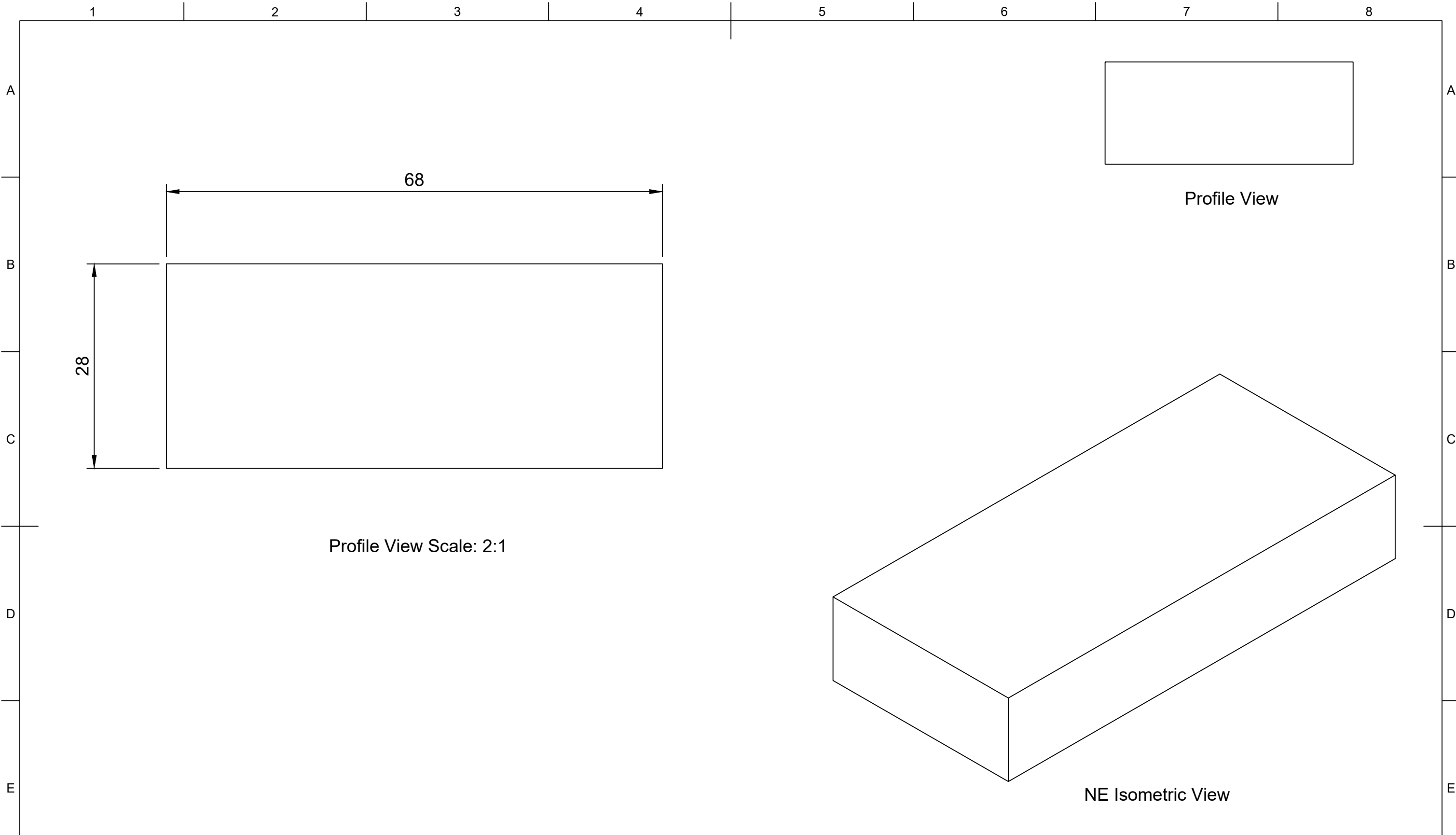

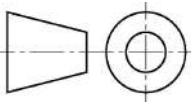
	Part Number				Created By		Cross Sectional Area (mm²)		Nominal Dimension (mm)		Tolerance, ± (mm)
	201949				Isaac Erskine		1904		Greater Than	Less Than or Equal to	
	Description				Date Drawn		Material				
	Rectangle - Solid				11/08/2020		EPDM				
					Approved By		Hardness (Shore A)				
					Isaac Erskine		70				
					Date of Approval		Colour				
					16/02/2022		Black				
					Projection		Weight (kg/m)				
					3rd Agl. 		2.399				
Revision	Date of Issue	Sheet Scale	Sheet Size	Sheet							
A	16/02/2022	1:1	A3	1/1							

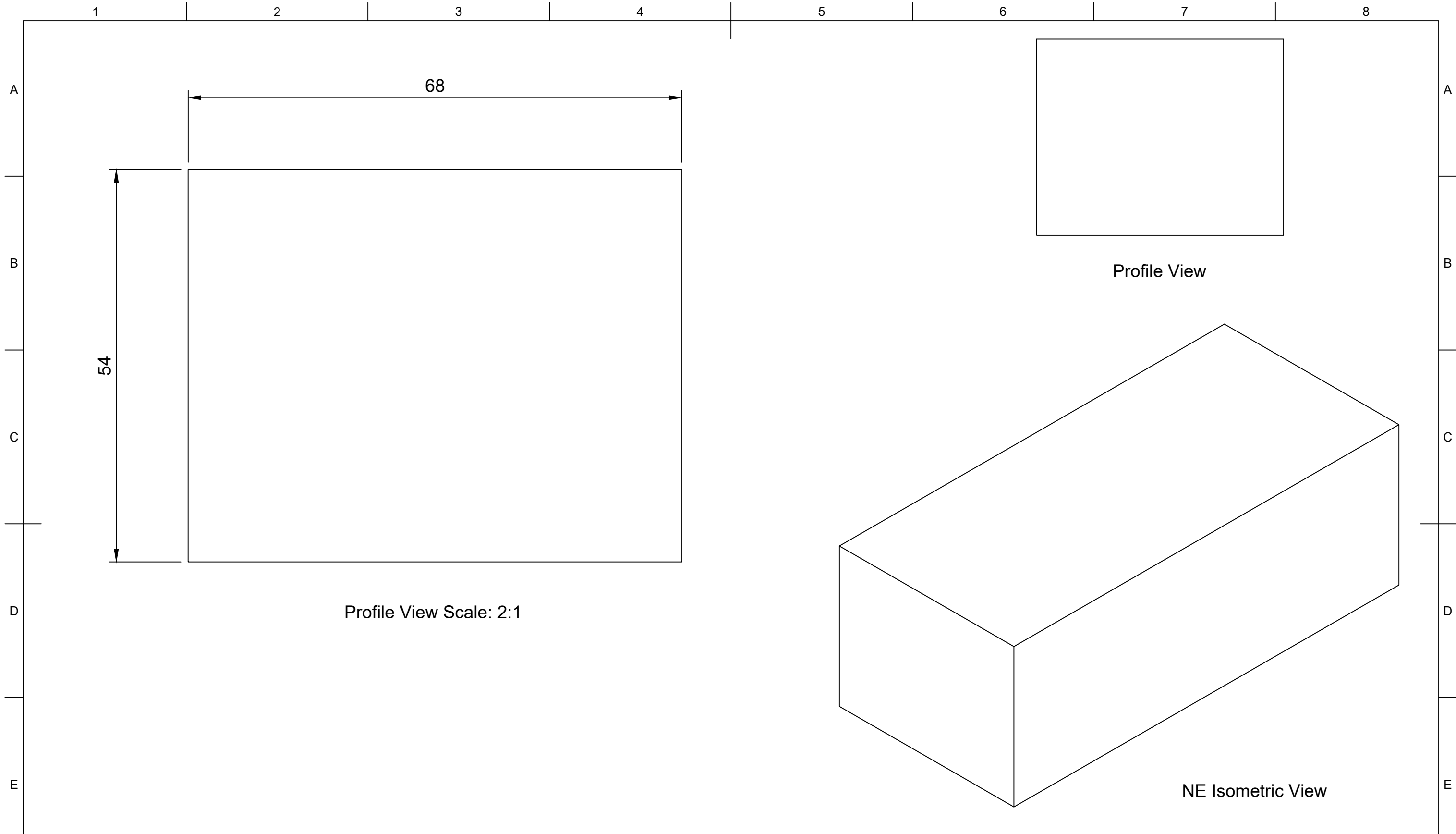

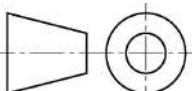
	Part Number				Created By		Cross Sectional Area (mm²)		Nominal Dimension (mm)		Tolerance, ± (mm)
	206610				Isaac Erskine		3670		Greater Than	Less Than or Equal to	
	Description				Date Drawn		Material		0.00	1.50	0.40
	Rectangle - Solid				11/08/2020		EPDM		1.50	2.50	0.50
	Revision				Approved By		Hardness (Shore A)		2.50	4.00	0.70
	A	16/02/2022		1:1	A3	1/1	Isaac Erskine		4.00	6.30	0.80
	Date of Issue				Date of Approval		Colour		6.30	10.00	1.00
	Sheet Scale				Projection		Weight (kg/m)		10.00	16.00	1.30
	1:1				3rd Agl. 		4.627		16.00	25.00	1.60
	Sheet Size								25.00	40.00	2.00
A3								40.00	63.00	2.50	
Sheet								63.00	100.00	3.20	
1/1								100.00		3.20%	

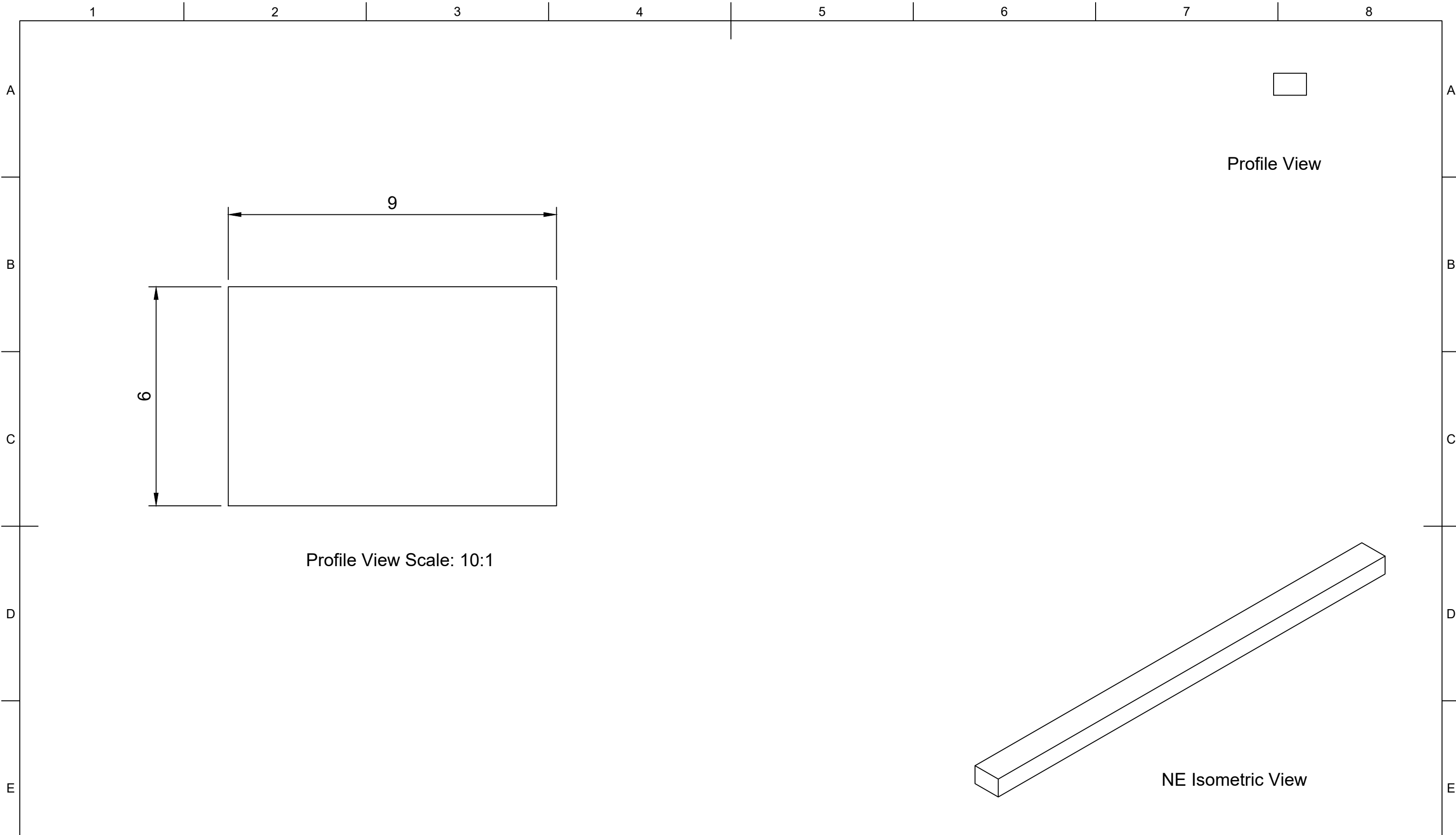



Profile View Scale: 10:1

NE Isometric View

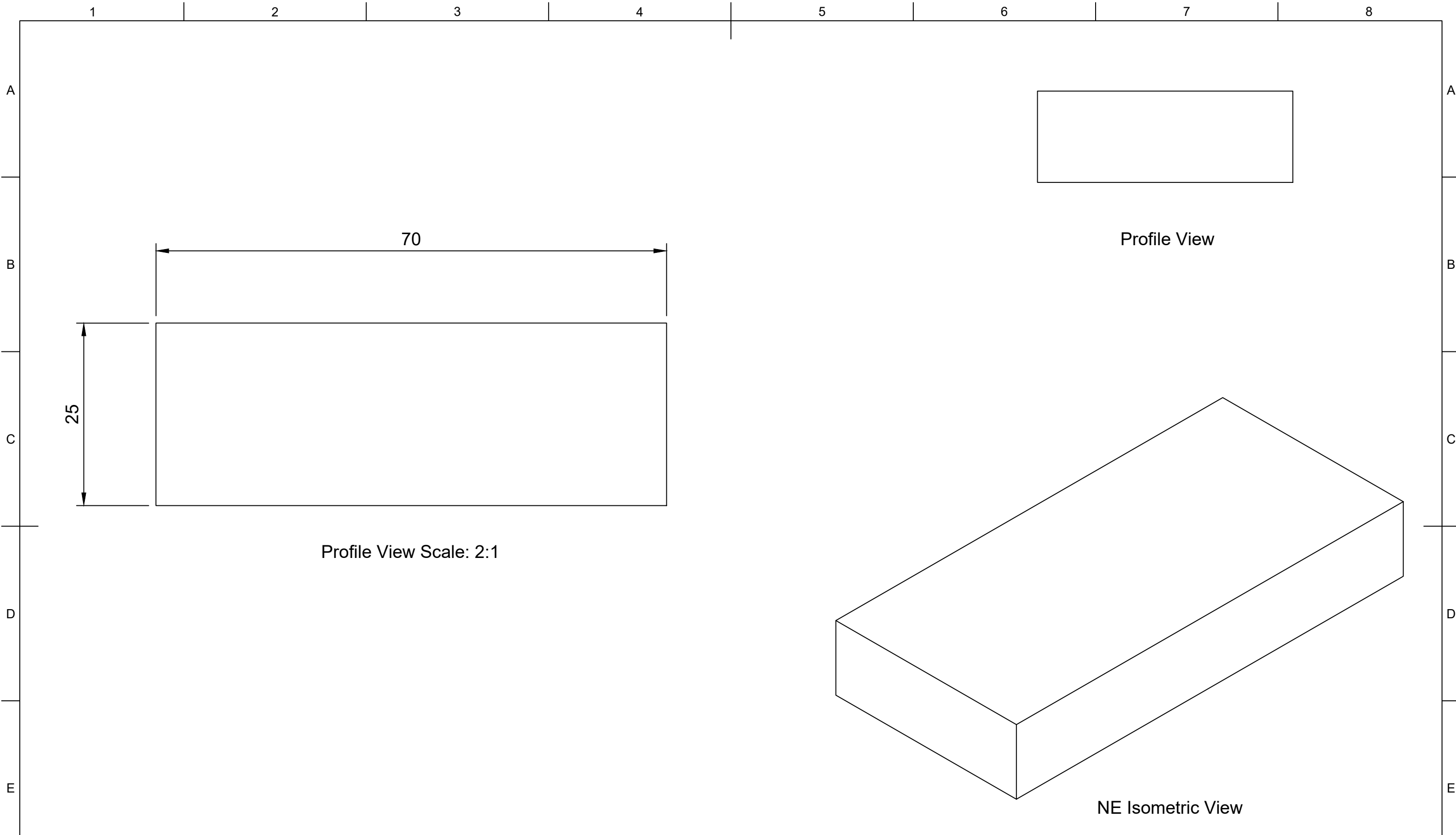

Part Number 209146					Created By Isaac Erskine		Cross Sectional Area (mm ²) 54		Nominal Dimension (mm)		Tolerance, ± (mm)						
					Date Drawn 11/08/2020		Material EPDM		Greater Than	Less Than or Equal to							
Description Rectangle - Solid					Approved By Isaac Erskine		Hardness (Shore A) 70		0.00	1.50	0.40						
					Date of Approval 16/02/2022		Colour Black		1.50	2.50	0.50						
					Revision A		Date of Issue 16/02/2022		Sheet Scale 1:1		Sheet Size A3		Sheet 1/1		2.50	4.00	0.70
					Projection 3rd Agl.		Weight (g/m) 68		4.00	6.30	0.80						
						6.30	10.00	1.00									
						10.00	16.00	1.30									
						16.00	25.00	1.60									
						25.00	40.00	2.00									
						40.00	63.00	2.50									
						63.00	100.00	3.20									
						100.00		3.20%									

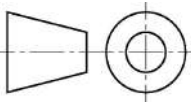

	Part Number				Created By		Cross Sectional Area (mm²)		Nominal Dimension (mm)		Tolerance, ± (mm)
	202335				Isaac Erskine		1750		Greater Than	Less Than or Equal to	
	Description				Date Drawn		Material		0.00	1.50	0.40
					11/08/2020		EPDM		1.50	2.50	0.50
	Rectangle - Solid				Approved By		Hardness (Shore A)		2.50	4.00	0.70
					Isaac Erskine		70		4.00	6.30	0.80
					Date of Approval		Colour		6.30	10.00	1.00
	16/02/2022		Black		10.00	16.00	1.30				
	Revision	Date of Issue	Sheet Scale	Sheet Size	Sheet	Projection	Weight (kg/m)		16.00	25.00	1.60
	A	16/02/2022	1:1	A3	1/1	3rd Agl. 	2.205		25.00	40.00	2.00
								40.00	63.00	2.50	
								63.00	100.00	3.20	
								100.00		3.20%	

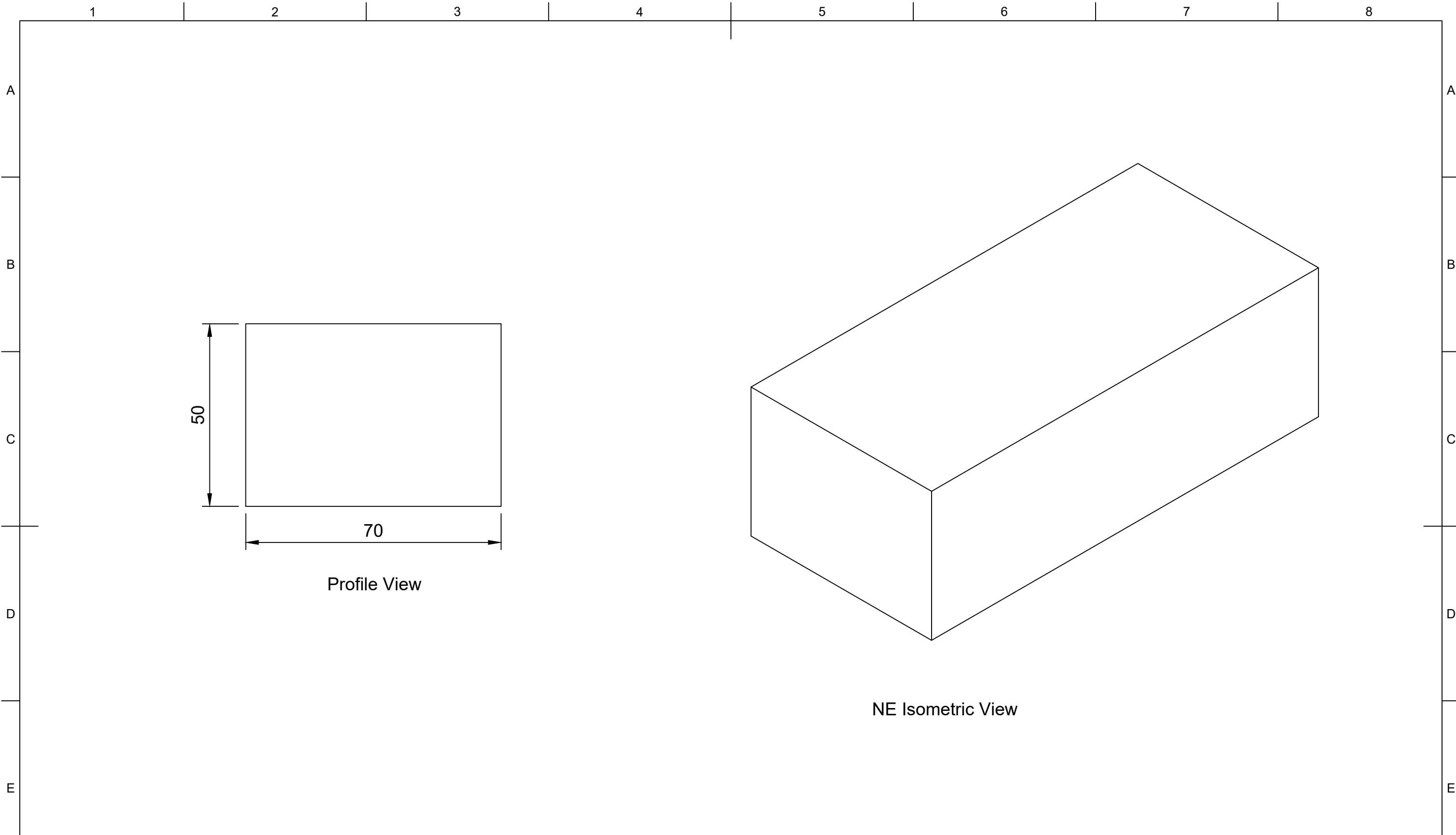

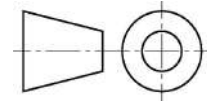
	Part Number				Created By		Cross Sectional Area (mm²)		Nominal Dimension (mm)		Tolerance, ± (mm)
	205585				Isaac Erskine		3500		Greater Than	Less Than or Equal to	
	Description				Date Drawn		Material		0.00	1.50	0.40
	Rectangle - Solid				04/08/2020		EPDM		1.50	2.50	0.50
	Revision				Approved By		Hardness (Shore A)		2.50	4.00	0.70
	A	16/02/2022		Isaac Erskine		70		4.00	6.30	0.80	
	Date of Issue		Sheet Scale		Date of Approval		Colour		6.30	10.00	1.00
	16/02/2022		1:1		16/02/2022		Black		10.00	16.00	1.30
	Sheet Size		Sheet		Projection		Weight (kg/m)		16.00	25.00	1.60
	A3		1/1		3rd Ang. 		4.410		25.00	40.00	2.00
								40.00	63.00	2.50	
								63.00	100.00	3.20	
								100.00		3.20%	

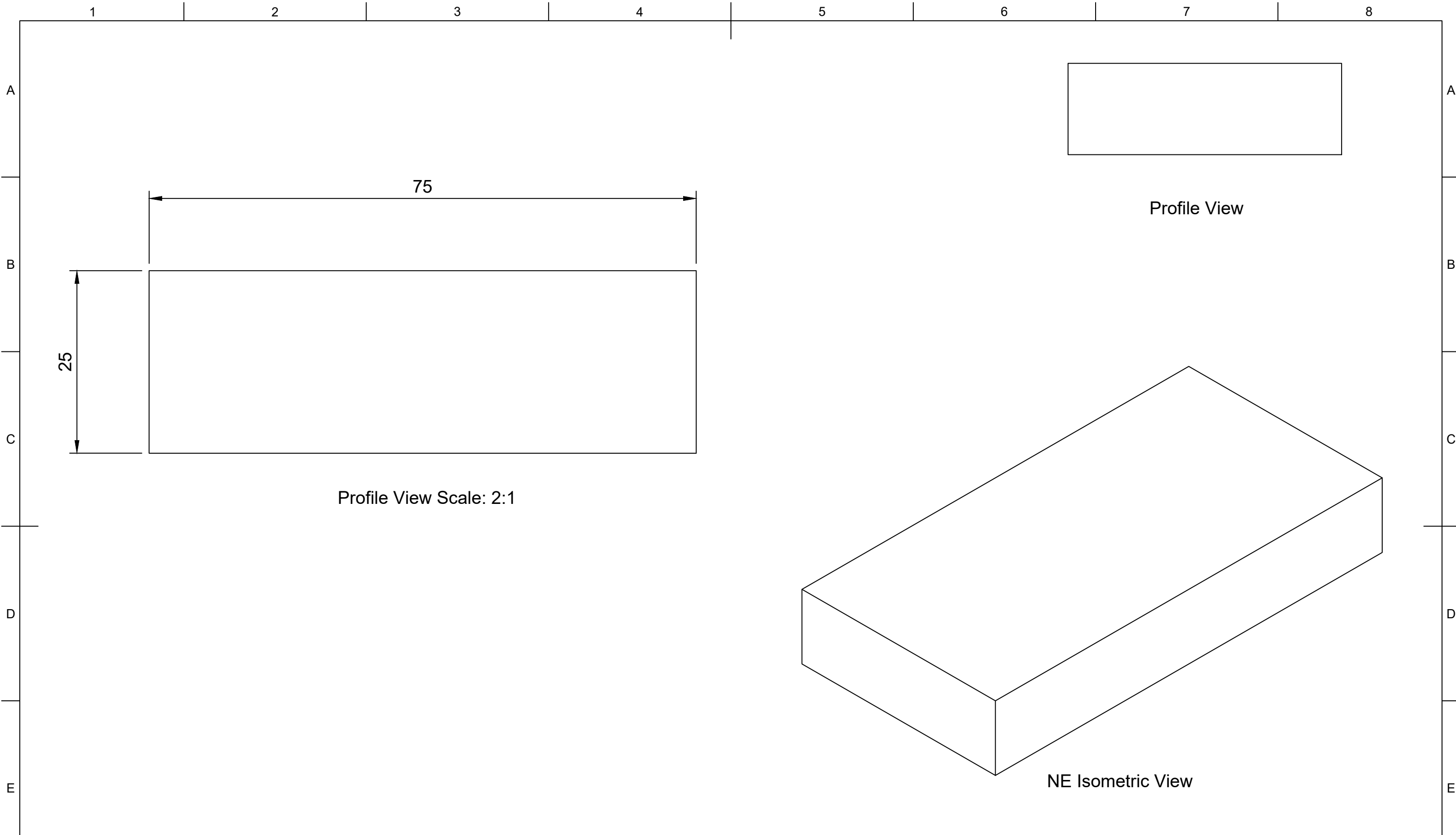

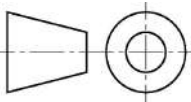
	Part Number				Created By		Cross Sectional Area (mm²)		Nominal Dimension (mm)		Tolerance, ± (mm)
	209041				Isaac Erskine		1875		Greater Than	Less Than or Equal to	
					Date Drawn		Material		0.00	1.50	0.40
					11/08/2020		EPDM		1.50	2.50	0.50
					Approved By		Hardness (Shore A)		2.50	4.00	0.70
	Description				Isaac Erskine		70		4.00	6.30	0.80
	Rectangle - Solid				Date of Approval		Colour		6.30	10.00	1.00
					16/02/2022		Black		10.00	16.00	1.30
					Projection		Weight (kg/m)		16.00	25.00	1.60
	Revision	Date of Issue	Sheet Scale	Sheet Size	Sheet	3rd Agl. 	2.363		25.00	40.00	2.00
A	16/02/2022	1:1	A3	1/1				40.00	63.00	2.50	
								63.00	100.00	3.20	
								100.00		3.20%	

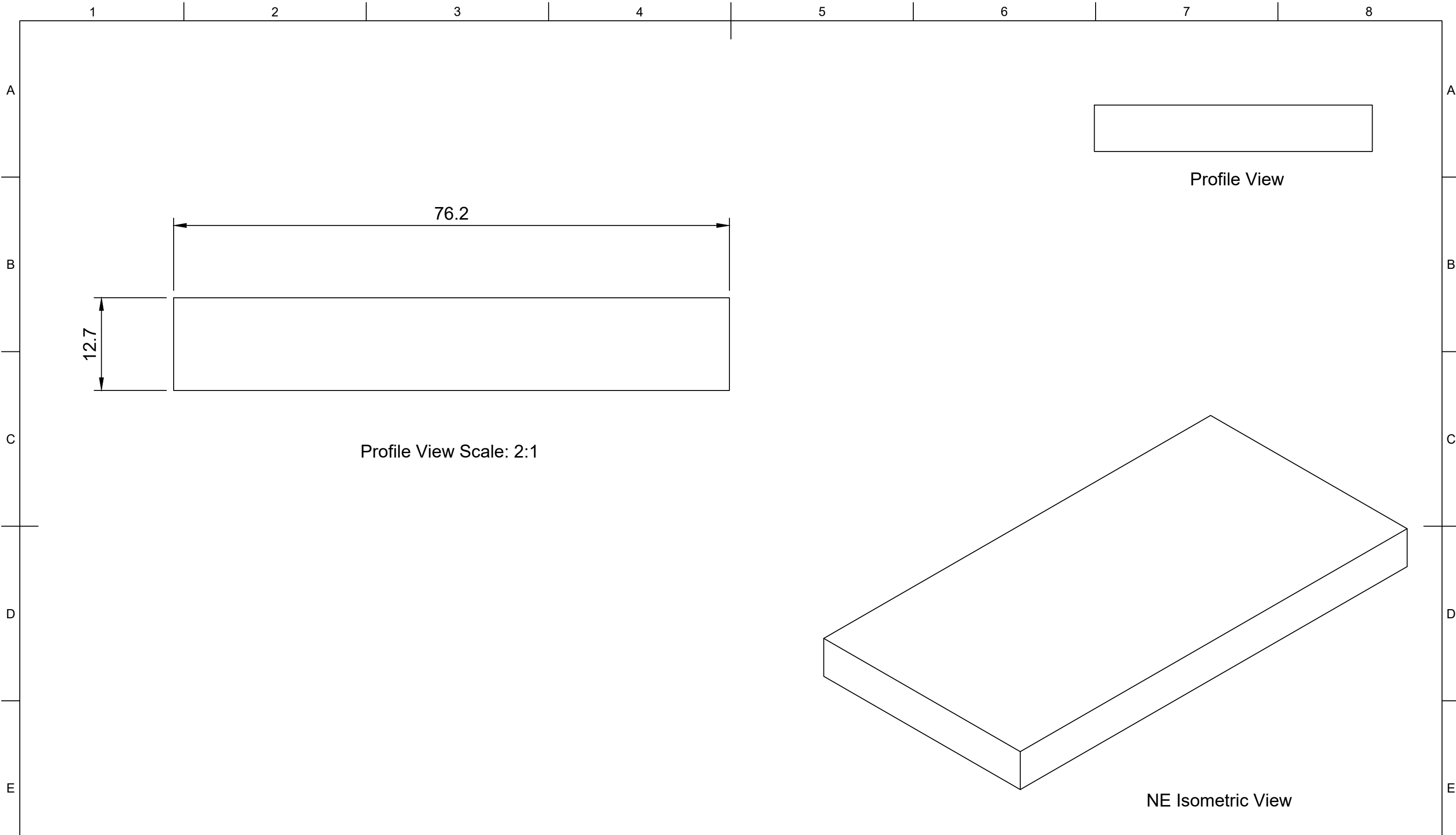

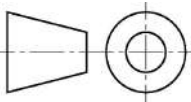
	Part Number				Created By		Cross Sectional Area (mm²)		Nominal Dimension (mm)		Tolerance, ± (mm)
	205481				Isaac Erskine		968		Greater Than	Less Than or Equal to	
	Description				Date Drawn		Material				
	Rectangle - Solid				11/08/2020		EPDM				
					Approved By		Hardness (Shore A)				
					Isaac Erskine		70				
					Date of Approval		Colour				
					16/02/2022		Black				
					Projection		Weight (kg/m)				
					3rd Agl. 		1.220				
Revision	Date of Issue	Sheet Scale	Sheet Size	Sheet							
A	16/02/2022	1:1	A3	1/1							
								25.00	40.00	2.00	
								40.00	63.00	2.50	
								63.00	100.00	3.20	
								100.00		3.20%	

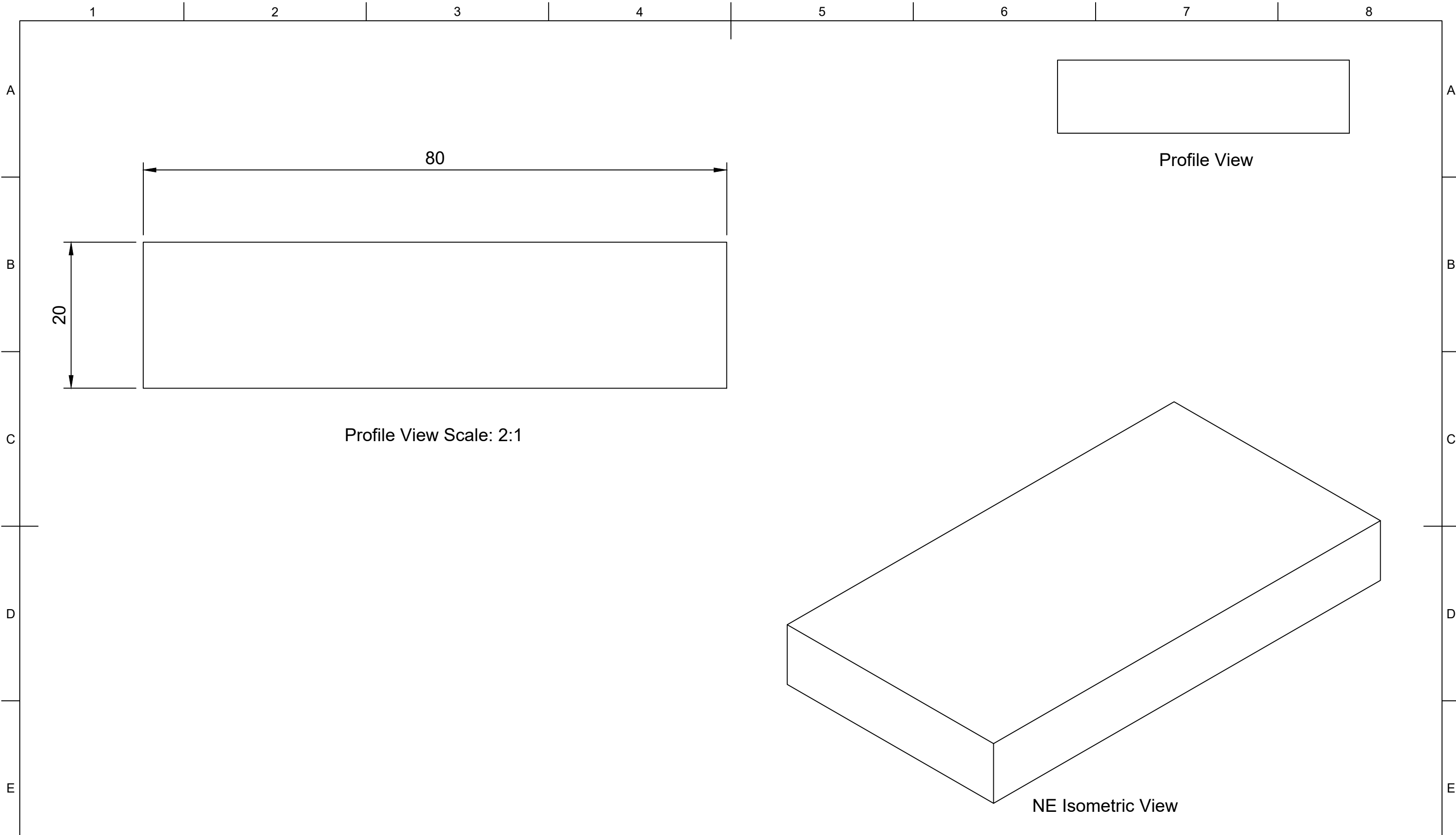

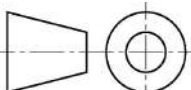
	Part Number				Created By		Cross Sectional Area (mm²)		Nominal Dimension (mm)		Tolerance, ± (mm)
	204061				Isaac Erskine		1600		Greater Than	Less Than or Equal to	
	Description				Date Drawn		Material		0.00	1.50	0.40
	Rectangle - Solid				11/08/2020		EPDM		1.50	2.50	0.50
	Revision				Approved By		Hardness (Shore A)		2.50	4.00	0.70
	A	16/02/2022		1:1	A3	1/1	Isaac Erskine		4.00	6.30	0.80
	Date of Issue				Date of Approval		Colour		6.30	10.00	1.00
	Sheet Scale				Projection		Black		10.00	16.00	1.30
	Sheet Size				3rd Agl. 		Weight (kg/m)		16.00	25.00	1.60
	Sheet						2.016		25.00	40.00	2.00
								40.00	63.00	2.50	
								63.00	100.00	3.20	
								100.00		3.20%	

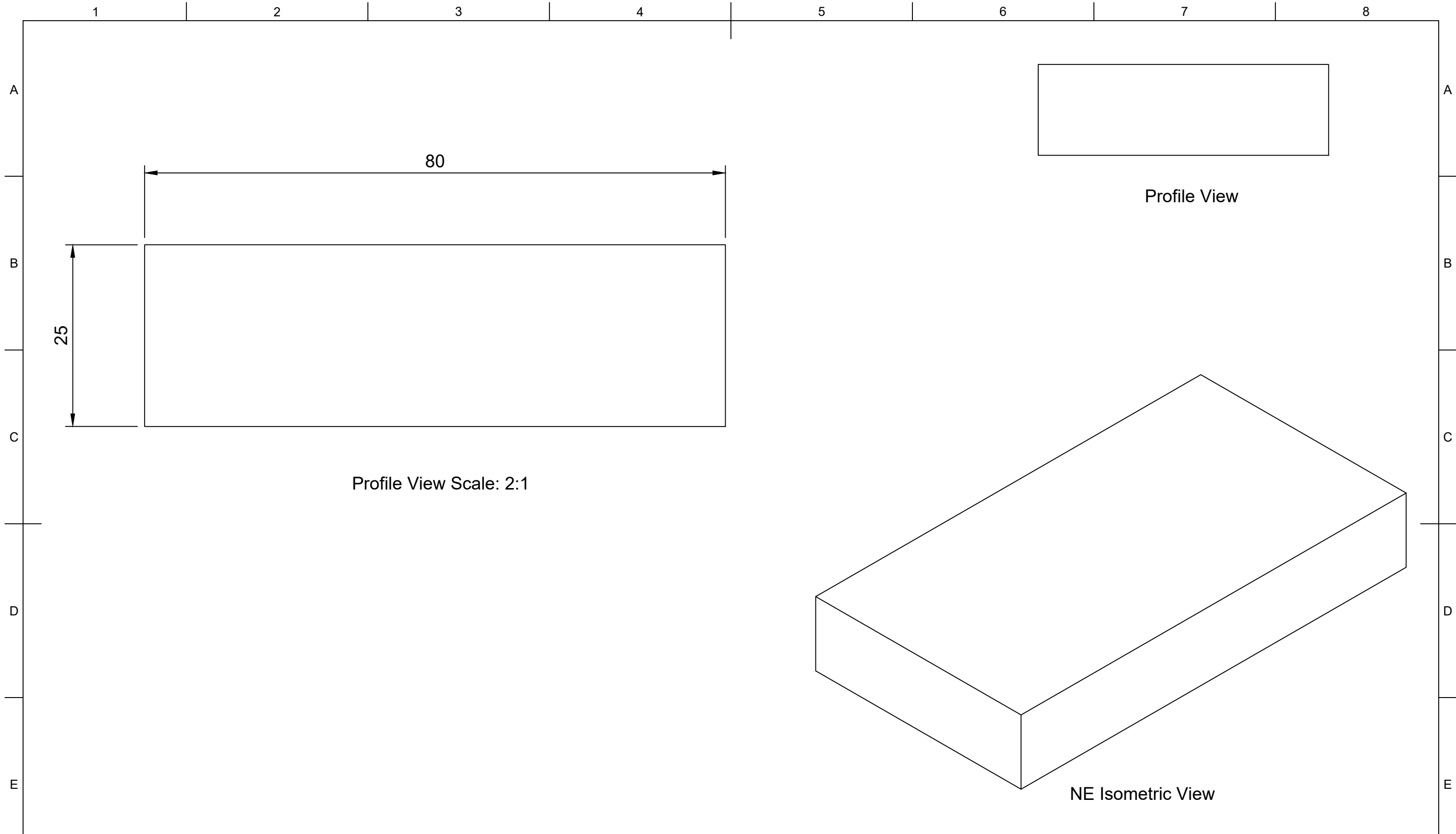

	Part Number				Created By		Cross-Sectional Area (mm ²):		Nominal Dimension (mm)		Tolerance ± (mm)		
	207189				Kev Parkin		2000		Greater Than	Less Than or Equal to			
	Description				Date Drawn		Material	Hardness (Shore A)	Colour	Weight (Kg/m)	0	1.50	0.40
	Rectangle Section - Solid				11/08/2020		EPDM	70	Black	2.520	1.50	2.50	0.50
	Revision	Date of issue	Sheet Scale	Sheet Size	Sheet	Approved by					4.00	6.30	0.70
A	24/08/2020	1:1	A3	1/1	David Stirling					6.30	10.00	1.00	
					Date of Approval					10.00	16.00	1.30	
					24/08/2020					16.00	25.00	1.60	
										25.00	40.00	2.00	
										40.00	63.00	2.50	
										63.00	100.00	3.20	
										100.00	—	3.20%	

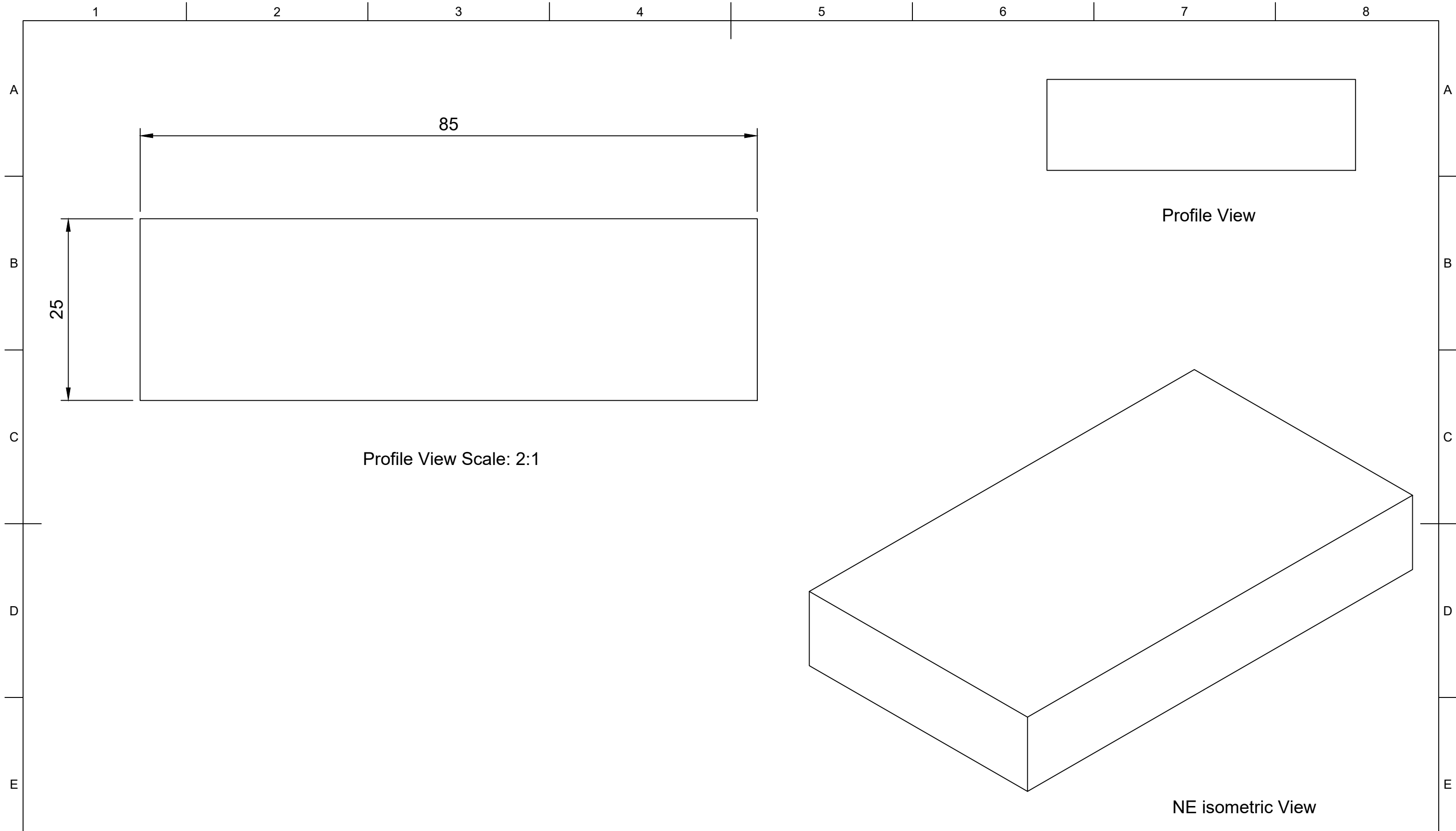

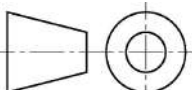
	Part Number				Created By		Cross Sectional Area (mm²)		Nominal Dimension (mm)		Tolerance, ± (mm)
	203038				Isaac Erskine		2125		Greater Than	Less Than or Equal to	
	Description				Date Drawn		Material				
	Rectangle - Solid				11/08/2020		EPDM				
					Approved By		Hardness (Shore A)				
					Isaac Erskine		70				
					Date of Approval		Colour				
					16/02/2022		Black				
					Projection		Weight (kg/m)				
					3rd Agl. 		2.678				
Revision	Date of Issue	Sheet Scale	Sheet Size	Sheet							
A	16/02/2022	1:1	A3	1/1							

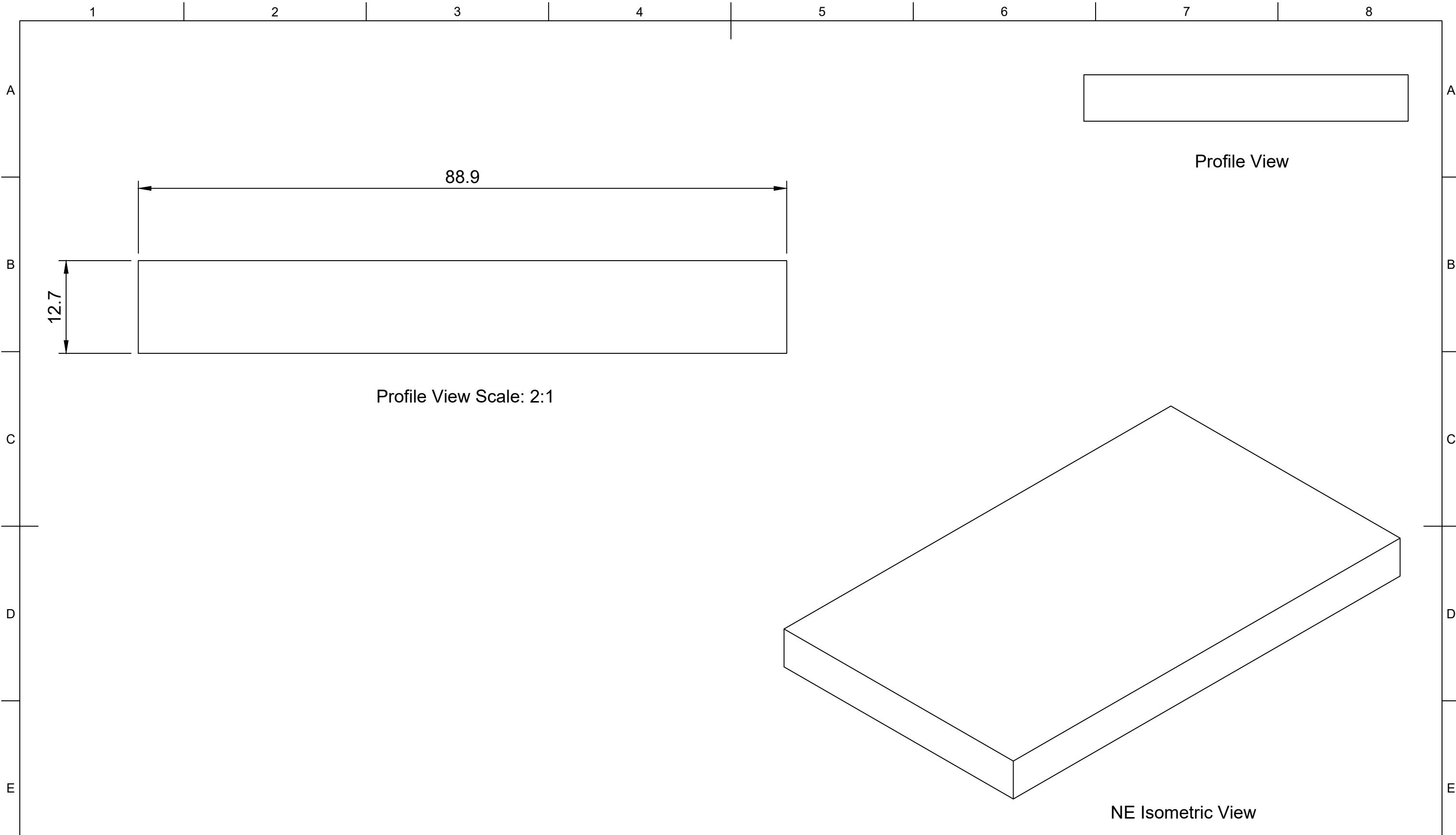

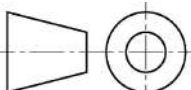
	Part Number				Created By		Cross Sectional Area (mm²)		Nominal Dimension (mm)		Tolerance, ± (mm)
	203334				Isaac Erskine		1129		Greater Than	Less Than or Equal to	
	Description				Date Drawn		Material		0.00	1.50	0.40
	Rectangle - Solid				11/08/2020		EPDM		1.50	2.50	0.50
	Revision				Approved By		Hardness (Shore A)		2.50	4.00	0.70
	A	16/02/2022		1:1	A3	1/1	Isaac Erskine		4.00	6.30	0.80
	Date of Issue				Date of Approval		Colour		6.30	10.00	1.00
	Sheet Scale				Projection		Black		10.00	16.00	1.30
	Sheet Size				3rd Agl. 		Weight (kg/m)		16.00	25.00	1.60
	Sheet						1.423		25.00	40.00	2.00
								40.00	63.00	2.50	
								63.00	100.00	3.20	
								100.00		3.20%	

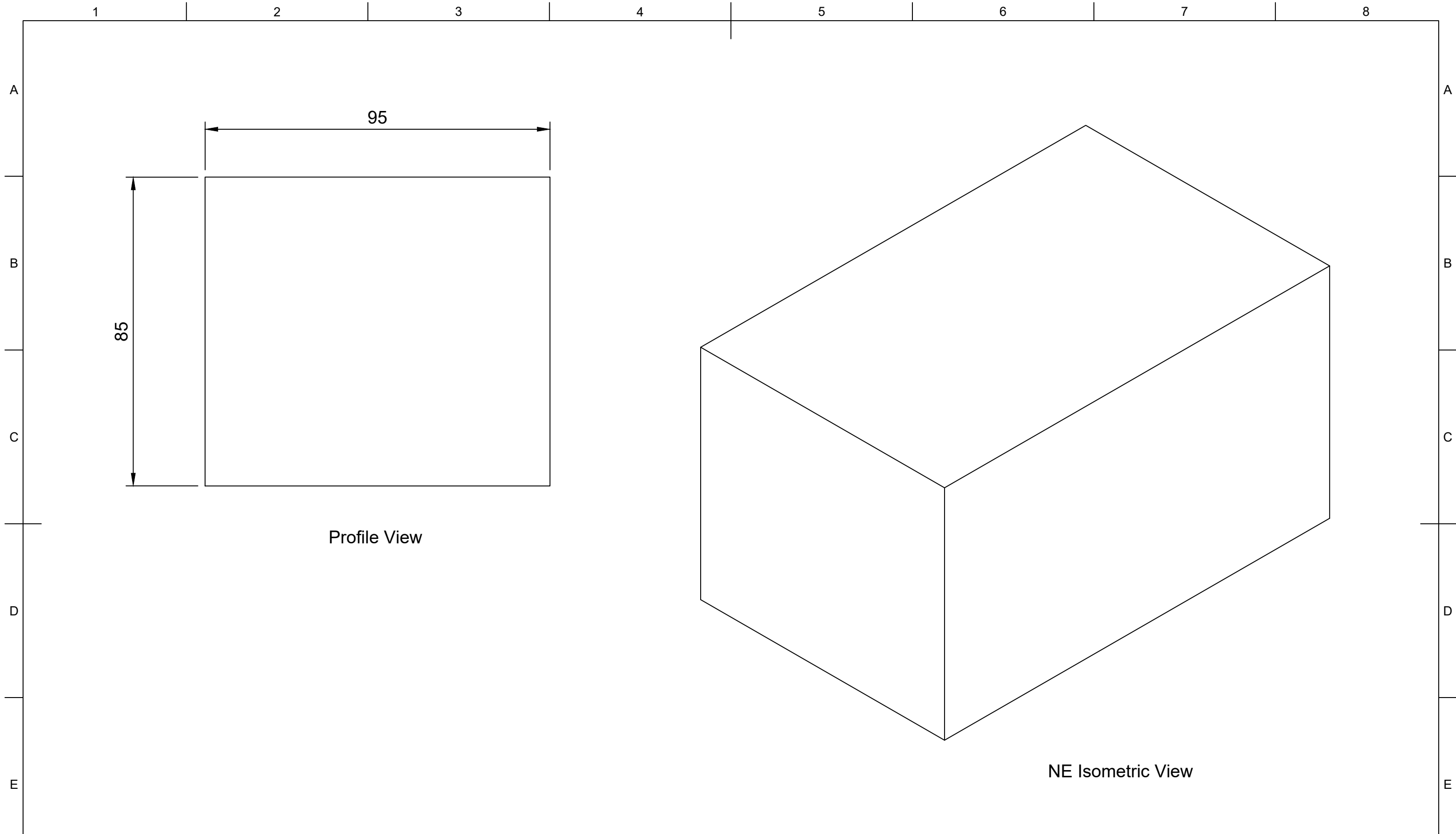

Profile View

NE Isometric View

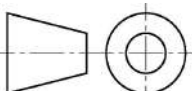
	Part Number				Created By		Cross Sectional Area (mm²)		Nominal Dimension (mm)		Tolerance, ± (mm)
	205311				Isaac Erskine		8075		Greater Than	Less Than or Equal to	
	Description				Date Drawn		Material				
	Rectangle - Solid				11/08/2020		Neoprene				
					Approved By		Hardness (Shore A)				
					Isaac Erskine		70				
					Date of Approval		Colour				
					16/02/2022		Black				
					Projection		Weight (kg/m)				
					3rd Agl. 		12.274				
Revision	Date of Issue	Sheet Scale	Sheet Size	Sheet							
A	16/02/2022	1:1	A3	1/1							

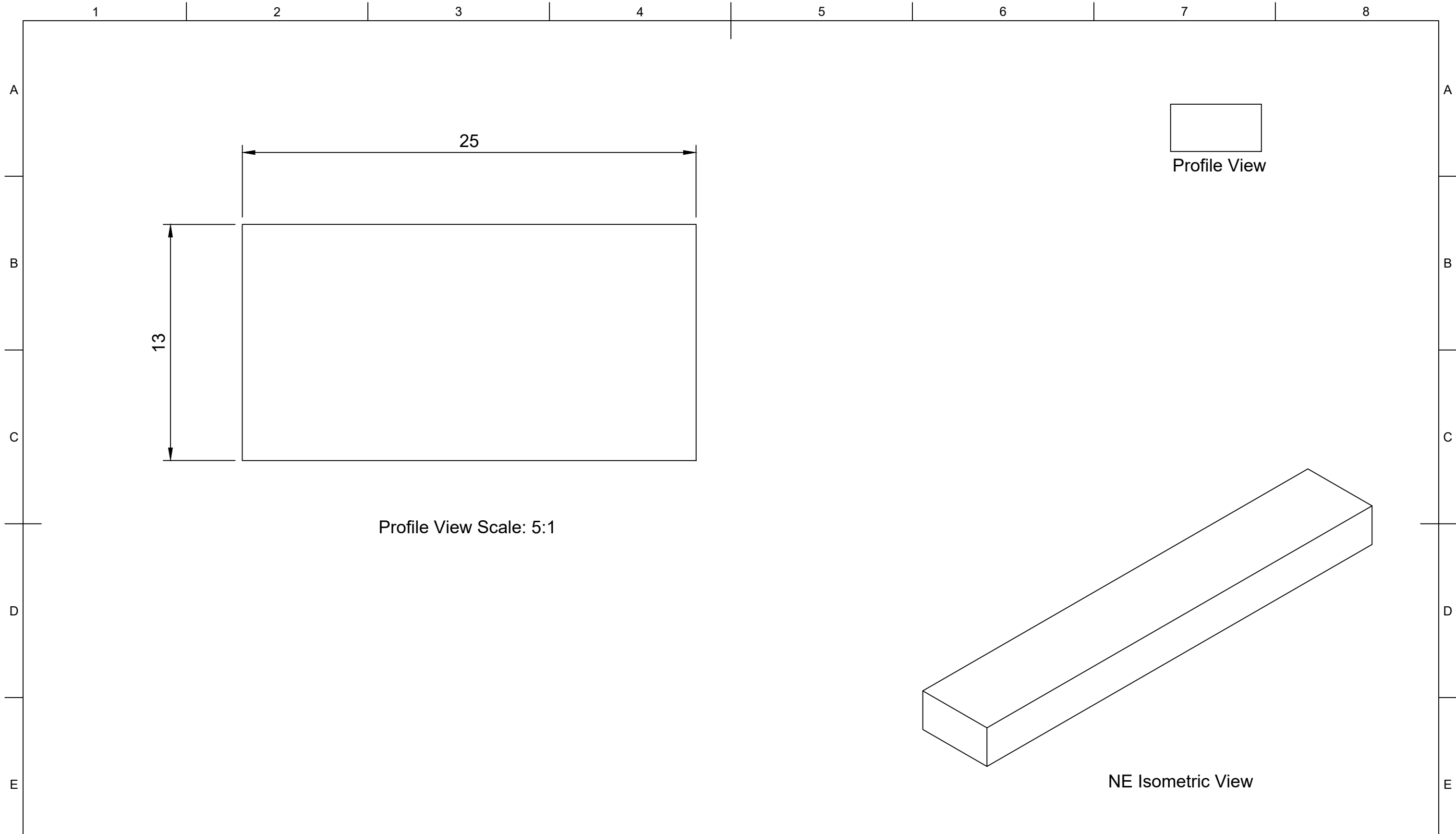

Profile View Scale: 5:1

NE Isometric View

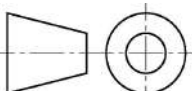
	Part Number				Created By		Cross Sectional Area (mm²)		Nominal Dimension (mm)		Tolerance, ± (mm)
	200266				Isaac Erskine		325		Greater Than	Less Than or Equal to	
	Description				Date Drawn		Material		0.00	1.50	0.40
	Rectangle - Solid				18/08/2020		EPDM		1.50	2.50	0.50
	Revision				Approved By		Hardness (Shore A)		2.50	4.00	0.70
	A	16/02/2022		1:1	A3	1/1	Isaac Erskine		4.00	6.30	0.80
	Date of Issue				Date of Approval		Colour		6.30	10.00	1.00
	Sheet Scale				Projection		Black		10.00	16.00	1.30
	Sheet Size				3rd Agl. 		Weight (g/m)		16.00	25.00	1.60
	Sheet				1/1		410		25.00	40.00	2.00
								40.00	63.00	2.50	
								63.00	100.00	3.20	
								100.00		3.20%	

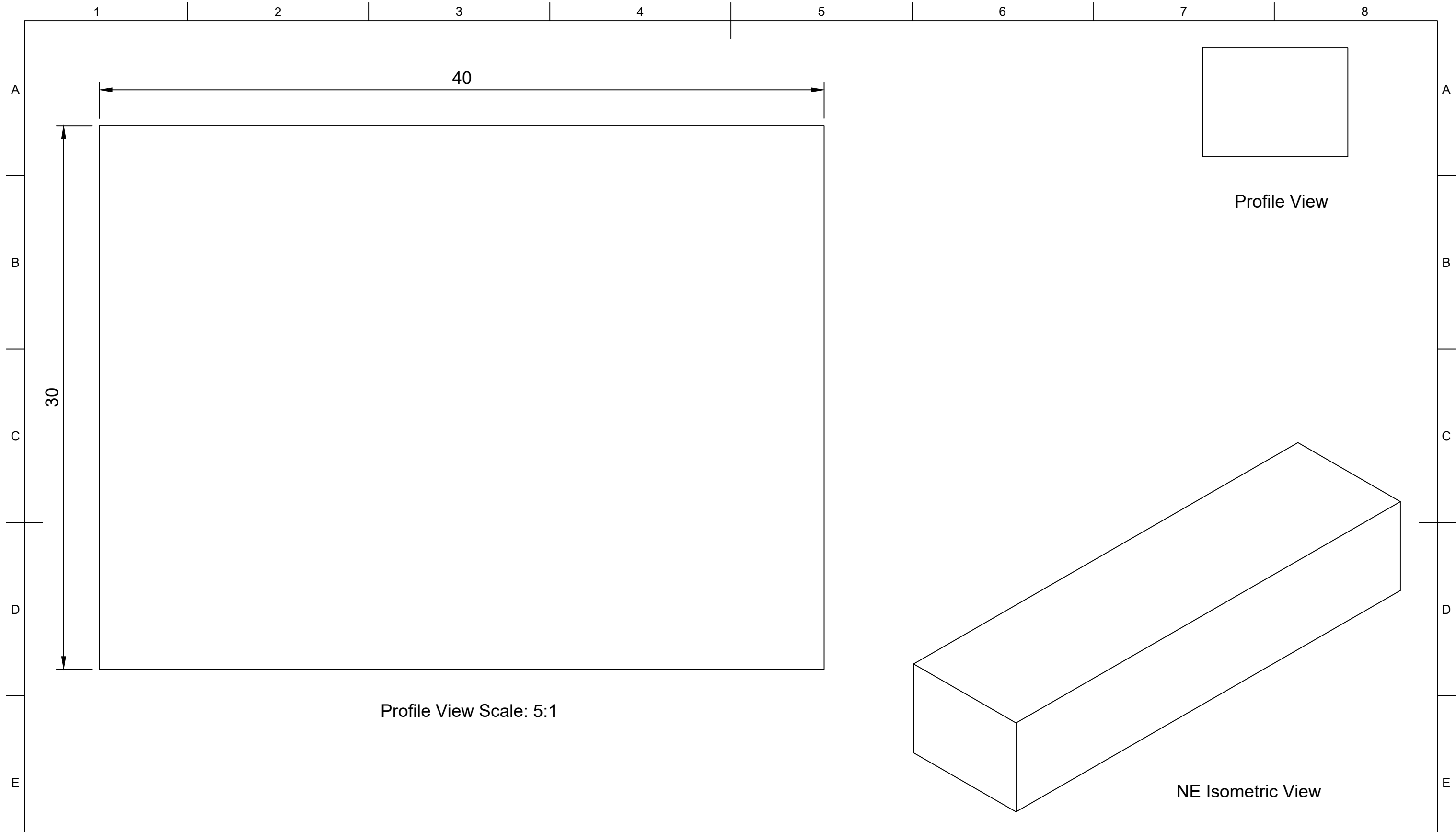

	Part Number				Created By		Cross Sectional Area (mm²)		Nominal Dimension (mm)		Tolerance, ± (mm)	
	209958				Isaac Erskine		1200		Greater Than	Less Than or Equal to		
	Description				Date Drawn		Material		0.00		0.40	
	Rectangle - Solid				30/08/2020		Nitrile		1.50		0.50	
	Revision				Approved By		Hardness (Shore A)		2.50		0.70	
	A	Date of Issue		Sheet Scale		Isaac Erskine		Colour		4.00		0.80
		16/02/2022		5:1		16/02/2022		Black		6.30		1.00
				Sheet Size		Date of Approval		Weight (kg/m)		10.00		1.30
				A3		16/02/2022		1.452		16.00		1.60
				Sheet		Projection				25.00		2.00
			1/1		3rd Agl.				40.00		2.50	
									63.00		3.20	
									100.00		3.20%	

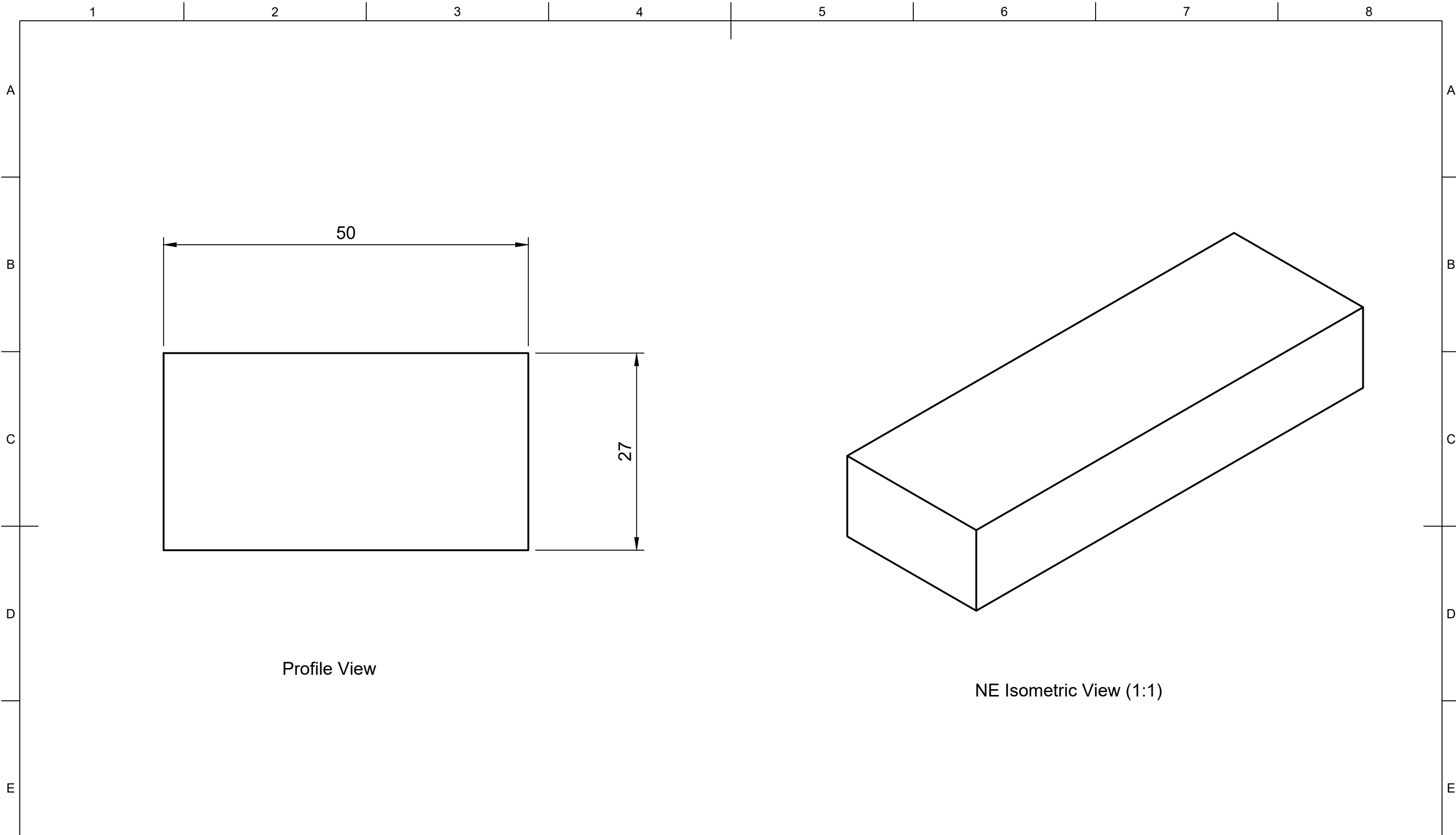

Profile View

NE Isometric View (1:1)

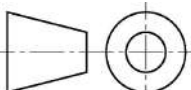
	Part Number				Created By		Cross Sectional Area (mm²)		Nominal Dimension (mm)		Tolerance, ± (mm)
	207695				Kevin George		1350		Greater Than	Less Than or Equal to	
	Description				Date Drawn		Material		0.00	1.50	0.40
					26/07/2022		EPDM		1.50	2.50	0.50
	Rectangle - Solid				Approved By		Hardness (Shore A)		2.50	4.00	0.70
					Date of Approval		50		4.00	6.30	0.80
	Revision				3rd Agl. 		Colour		6.30	10.00	1.00
									Black		10.00
	Date of Issue		Sheet Scale		Sheet Size		Weight (g/m)		16.00	25.00	1.60
	26/07/2022		2:1		A3		1.593		25.00	40.00	2.00
Sheet		Sheet		Sheet		Sheet		40.00	63.00	2.50	
A		1/1		1/1		1/1		63.00	100.00	3.20	
								100.00		3.20%	